

Swing Away Heat Press Machine Manual

Model NO.: SA-15/20/24

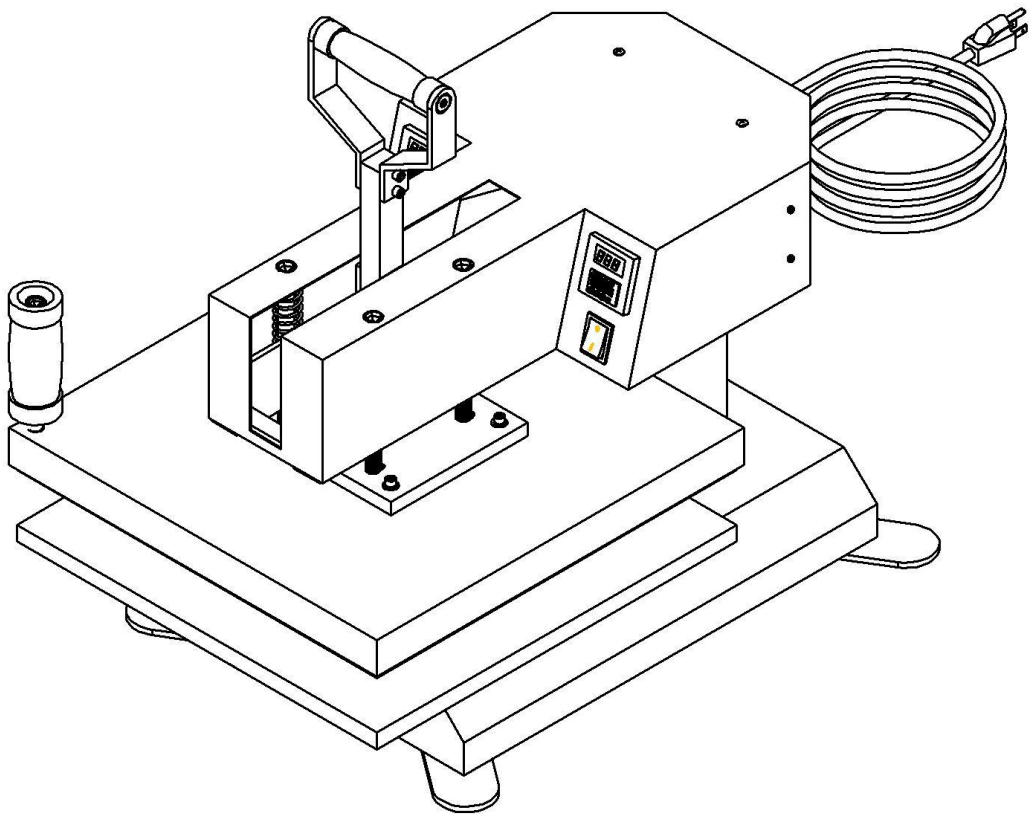

CONTENTS

I. Assembly Drawing	2
II. Technical Parameters	2
III. Operation Process	3-4
IV. Maintenance	5
V. Trouble Shooting For Transfer Print Quality.....	5
VI. Circuit Diagram	6
VII. Explosion View	7-8

I. Assembly Drawing

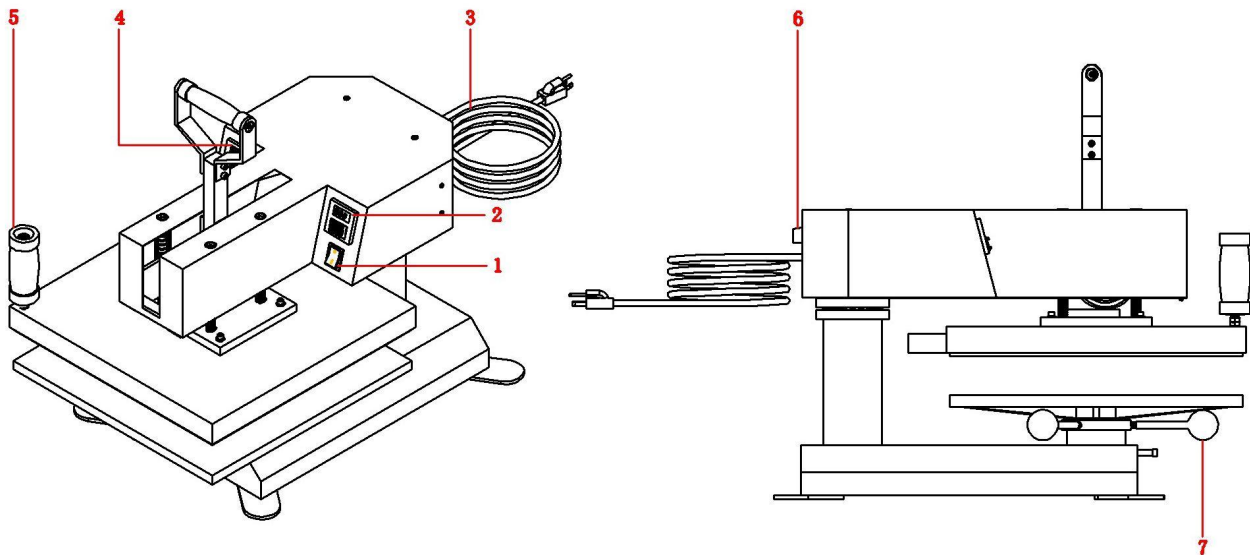

- | | | | |
|----------------|--------------------------|---------------------|-------------------|
| ① Power Switch | ② Temperature Controller | ③ Power Cord | ④ Time Controller |
| ⑤ Swing Handle | ⑥ Fuse | ⑦ Pressure Adjuster | |







II. Technical Parameters

1. Model No.: SA-15/20/24
2. Machine Dimension: 630*325*390mm/ 630*325*520mm/630*325*620mm
3. Heat Platen Size: 15 x 20", 16"x20", 20"x24" (38 x 38, 40x50, 40x60cm)
4. Printable Articles Max Size: 380*380*10mm
5. Voltage: 220V/1Phase; 110V/1Phase
6. Power: 220V/1.8KW; 110V/1.2KW
7. Recommend Setting: 30~280s; 180~200°C
Time Range: 0~480s
Maximum Temp: 225 C°
8. Packing Size: 73*48*48cm/ 75*60*50cm/ 74*69*49cm
9. Gross Weight: 40.95kg/ 50.3kg/ 52.55kg

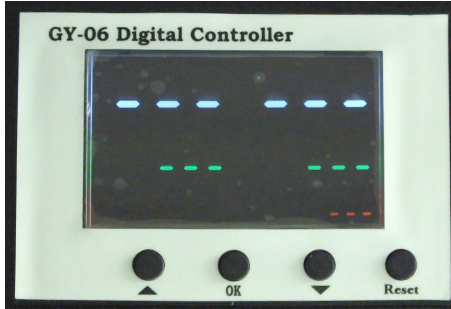



III. Operation Process

GY06 Digital Controller Operation Process

1. Set temperature required

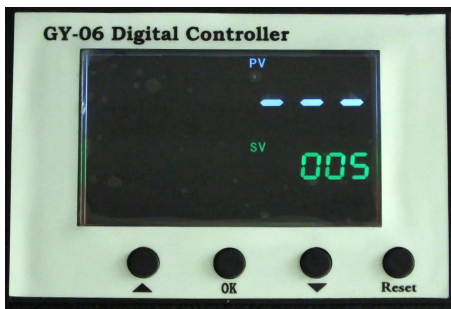
		
<p>Turn on power switch, temperature light is ON. The digital display shows as above.</p>	<p>Press  button, the  light is on (C denotes Celsius). Press arrows “△” or “▽” to select “C” or “F” (F denotes Fahrenheit) according to your habits.</p>	<p>Press  button, the temp  light is on. Select with arrows the temperature according to different transfer material (Normally 180°C~200°C) SV: Set temperature PV: Current temperature</p>



2. Set time required

	
<p>Press  button after temperature setting and the time light is on. Select with arrows the time according to different transfer material. SV: Set temperature PV: Current temperature</p>	<p>Press  button to operating mode. Counter is “transfer cycle”, from 0~999. Press “Reset” for 5 seconds to make the counter to be “0”.</p>

NOTE: Please do as follow:

- 1) When SV and PV has a big difference
- 2) When the temperature shows on the display is not the same as actual temperature on heat platen



When SV and PV has a big difference, press  button for 5 seconds, and press  button again to adjust the temperature. If SV&PV has difference of 20 degrees, Press arrows "△" or "▽" to set to 20.

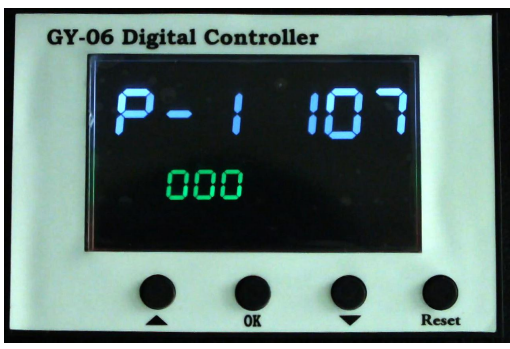

When the temperature shows on the display is not the same as actual temperature on heat platen, press  button for 5 seconds to reset mode:
 ① When display shows 200°C, the actual heat platen temperature is 170 °C, Press arrows "△" or "▽" to set to 30.
 ② When display shows 200°C, the actual heat platen temperature is 230 °C, Press arrows "△" or "▽" to set to -30

3. Printing methods

- Step 1:** Make sure the cord is connected well to the wall socket. Place the object (i.e. T-shirt) on press bed, and transfer paper with images facing down the object, adjust pressure to your requirement, and start the machine.
- Step 2:** Set the temperature and time required, then temperature starts to rise.
- Step 3:** When the temperature rises to the setting temperature, the buzzer sends out sounds; then close down heat platen (meantime the sounds stop) and starts to transfer.
- Step 4:** Then the time counter is on, once time is up, the upper heat platen will auto open and swing away to another side automatically.
- Step 5:** Consult the Transfer Paper instructions on whether to peel cold or hot, Here are suggested Pressing time guidelines for different transfer paper.

- Ink-Jet Transfer Paper (fabric) 14-18 seconds
- Laser Copier/Printer Transfer Paper (fabric) 18-25 seconds
- Sublimation Transfers (onto Fabrics) 25-30 seconds
- Sublimation Transfers (onto FR-Plastic/Woods) 60-70 seconds

5. Recommendations:

- 1) Ceramic tile transfer:
Set temperature: 180°C.
Set time: 15 seconds
- 2) T-shirt transfer:
Set temperature: 180°C.
Set time: (chemical fiber use for sublimation transfer paper: 30-50 seconds; pure cotton use for T-shirt transfer paper: 10-20 seconds)
- 3). Aluminum sheet transfer:

Set temperature: 180°C

NOTE:

- 1) Please switch off the machine and unplug the power cord when the machine is not in use.
- 2) The heat platen will cool down to the room temperature, if heat press stays unuse for more than 30 minutes.
- 3) The heat-releasing fan will automatically starts when the temeprature of heat platen reaches 80 degree C (176 degree F). It helps to reduce the temperature of electrical parts and prolong the service life of them.
- 4) For better maintenance of heat press, the maximum setting temperature is 210 degrees C (410 degrees F).
- 5) To avoid re-heating the first transfer when printing double sided T-Shirts, insert a sheet of cardboard in between the shirt, adjust the height to less pressure, then press.
- 6) Heat platen may pivot slightly back and forth rotationally. This is due to movement allowance within the clamp assembly, and is normal.

IV. Maintenance

1. No action after turn on the machine

- 1). Check the plug whether it connects well or whether it is broken.
- 2). Check the power switch or digital controller whether it is broken.
- 3). Check the fuse whether it has been burnt out.
- 4). Indicating light is on, but no display on screen, check the 5 cable of Railway transformer. If it's loosening, showing the problem is poor connection. If they connects well, showing that the Transformer is faulty.

2. The display screen are working well, but no temperature increasing on the heat platen.

- 1). Check whether the thermocouple of the heat platen touches well. If the thermocouple is loose, the display will show 255 and machine keeps beeping.
- 2). Check if the indicating light of solid-state relay is on, if not, check if the relay or digital controller is broken.
- 3). If you already changed the new solid-state relay but the heat platen still can't heating up, check if the heat platen is faulty or the heat platen's power cable is loose, need to change by new heat platen.

3. The heat platen works well, but suddenly the display screen show 255°C.

- 1). Check whether the thermocouple of the heat platen touches well.
- 2). If the thermocouple touches well but still show 255°C, then it is faulty.

4. The machine is heating during 0~180°C, but display number jumps to above 200°C or 300°C suddenly, or the numbers on display jumps irregularly.

- 1). Check whether the thermocouple of the heat platen touches well.
- 2). If the thermocouple is good, It shows that the program of digital controller is broken, which namely IC or is broken, need to change by new controller.

5. The temperature is out of control: Set 180°C, but the actual temperature is above 200°C.

- 1). It means the solid-state relay is broken, out of control, need to change the relay.
- 2). Or the digital controller is faulty and it keeps conveying electric to relay, need to change controller.

6. The setting temp and time becomes abnormal after exchange the heat platen

- 1). Please reset the temp and time according the operation process manual.

7. Other notice

- 1). In order to prolong the machine service life, please add the lubrication oil regularly on the joints.
- 2). In order to keep the heat platen's good transfer effect, you need to protect the heat platen carefully whenever you are using it or not.
- 3). Please keep the machine in dry place.
- 4). If you are not able to solve the electrical parts problem, please kindly contact the supplier and get technical support.

V. Trouble shooting for transfer print quality

1. If the print color is pale: the temperature is too low / the pressure is not correct / or not pressed long enough.
2. If the print color is too brown or the transfer paper is almost burnt: reduce the setting temperature
2. If the print is blurring: too much transfer time causes proliferation.
3. If print color is different/ partial transfer effect is not good enough: the pressure is not enough / or not pressed long enough / or poor quality transfer paper.
4. If transfer paper stick to the object after transfer: the temperature is too high/ or poor quality printing ink.

VI. Circuit Diagram

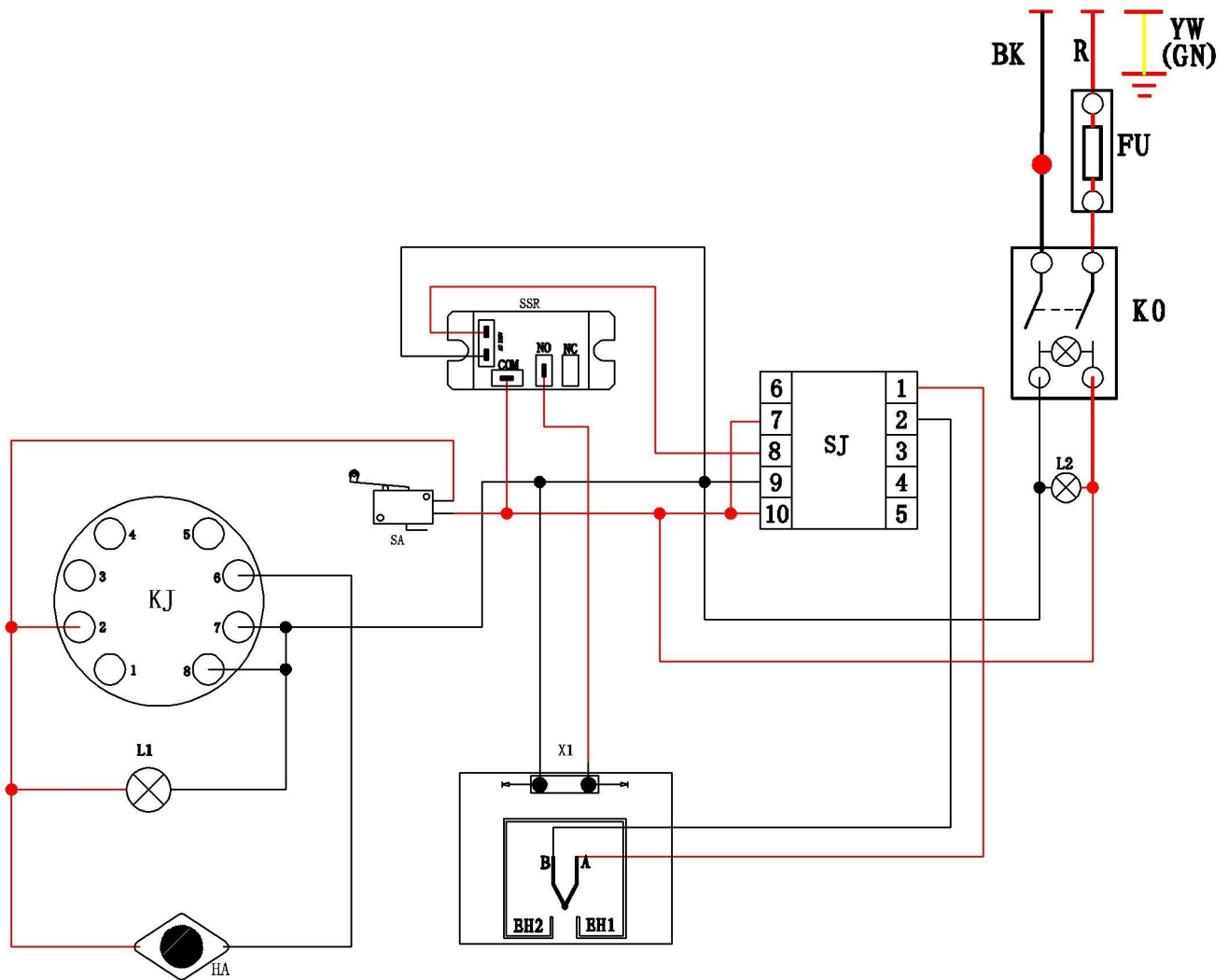

K₀: Power Switch
 L1: Time Indicator

SA: Limit Switch
 KJ: Time Relay
 L2: Temperature Indicator

FU: Fuse
 SSR: Solid State Relay
 HA: Buzzer

EH₁EH₂: Heating Pipe
 R1: Relay
 X1: Terminal

VII. Explosion View

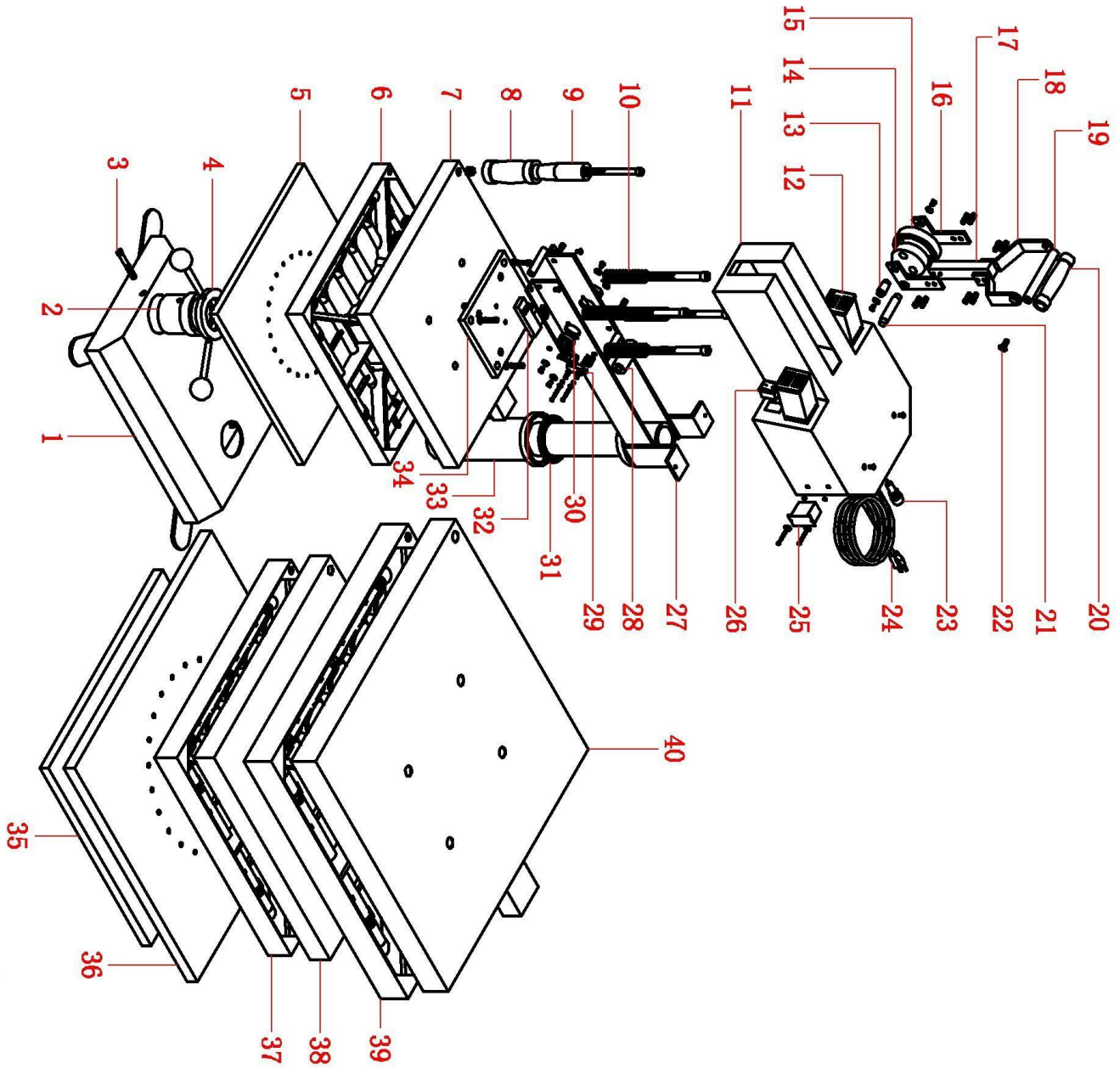

Serial Name	Parts Name	Qty
1	Machine Base	1

2	Support Pillar	1
3	Inner Hexagonal Screw	1
4	Adjusting Gear	1

5	Under Plate	2
6	Heat Platen	1
7	Heat Platen Metal Cover	1
8	Pillar	1
9	Pillar Shaft	1
10	Spring	4
11	Davit Arm	1
12	Time & Temp Controller	1
13	Fixing Axis	1
14	Roller	1
15	Machine Bearing	1
16	Fixing Piece	1
17	Roller Fitting	1
18	Handle	2
19	Handle Shaft	1
20	Handle Bar Grip	1
21	Wheel Shaft	1
22	M8 Screw	10

23	Fuse	1
24	Power Cord	1
25	Relay	1
26	Power Switch	1
27	Fixing Piece	1
28	Rubber Rod	2
29	Power Switch	1
30	6061 Machine Bearing	2
31	51102 Machine Bearing	1
32	Adapting Plate	1
33	Pillar	1
34	Adapting Plate	1
35	400*500 Under Plate	1
36	400*600 Under Plate	1
37	400*500 Heat Platen	1
38	400*500 Heat Platen Cover	1
39	400*600 Heat Platen	1
40	400*500 Heat Platen Cover	1