



Skycut Series D and V with SignMaster Pro

September 3, 2021

You can expect updates to this manual over the next few months

Do NOT read this entire manual... unless you want to.

- At the start of Chapters 1 - 4 are short sections with references to find what you need plus some important reminders. PLEASE read these short sections at the very least and refer back to them, when needed.
- Chapters 1 and 2 are very important in terms of correctly setting up your Skycut to work with SignMaster and learning the ins and outs of cutting.
- Chapter 3 is for those owners wanting to perform print and cut applications.
- Chapter 4 covers using Skycut accessory tools and dual head applications.
- Chapter 5 covers several SignMaster functions of interest: creating contour cuts and engraving fills.

It's not practical to print this entire manual because:

- It's a waste of paper and ink if you only ever need certain sections.
- The live links to videos and web sites in the manual will not work.
- This manual will be updated from time to time.
- You cannot search on individual words.

Also:

- Videos of interest can be found at the following link: [Skycut Support Videos](#)



Table of Contents



SKY CUT SERIES D AND V WITH SIGNMASTER PRO	1
1. INTRODUCTION AND SETTING UP	5
1.00 QUICK REFERENCE FOR THIS CHAPTER	5
1.01 SUPPORT	5
1.02 SAFETY AND WARNINGS	5
1.03 WARRANTY	6
1.04 UNPACKING	6
1.05 CONTENTS Video	6
1.06 PARTS OF THE SKY CUT Video	7
<i>Front</i>	7
<i>Right Side</i>	8
<i>Left Side</i>	8
<i>Back</i>	8
1.07 ACCESSORIES	9
1.07.1 <i>Assembling the Skycut D Stand (optional)</i>	9
1.07.2 <i>Tables (optional)</i>	9
1.07.3 <i>Test Pen</i>	10
1.07.4 <i>Skycut Blades</i>	10
1.07.5 <i>Blade Installation</i>	11
1.08 PREPARING AND CARING FOR THE CUTTING MAT	12
1.08.1 <i>Tips on Using the Cutting Mat</i>	12
1.08.2 <i>Cleaning and Replenishing the Cutting Mat</i>	12
1.09 PINCH WHEELS	13
1.09.1 <i>Raising and Lowering</i>	13
1.09.2 <i>Pinch Wheel Locations</i>	14
1.10 CONTROL PANEL	14
1.10.1 <i>Set Screen</i>	15
1.11 REGISTERING AND INSTALLING SIGNMASTER	15
1.11.1 <i>Installing from a Download</i>	16
1.11.2 <i>Installing from a CD</i>	16
1.12 CONNECTING THE SKY CUT TO YOUR COMPUTER Video	19
1.12.1 <i>USB Connection</i> Video	20
1.12.2 <i>Wi-Fi Connection</i> Video	21
1.12.3 <i>Wireless Stand-Alone</i>	24
1.12.4 <i>USB Flash Drive</i> Video	26
1.13 TEST DRAW SHAPES	30
1.14 DEFAULT SETTINGS TO CONSIDER	37
1.14.1 <i>Advanced Settings</i>	37
1.14.2 <i>General Settings</i>	39
1.14.3 <i>Sys Information</i>	41
1.15 MAINTENANCE	42
1.16 OTHER USEFUL TOOLS AND SUPPLIES	42
2. CUTTING	44
2.00 QUICK REFERENCE FOR THIS CHAPTER	44
2.01 WHAT YOU NEED TO UNDERSTAND ABOUT CUTTING	44
2.01.1 <i>You Have To Make Mistakes</i>	44
2.01.2 <i>Record Your Successes</i>	45
2.01.3 <i>Installing the Blade Holder, Test Pen, or Accessory Tools</i>	45

2.01.4 Adjust the Speed, Force, and Number of Passes Based on the Material and Shapes	46
2.01.5 Perform Test Cuts!.....	46
2.01.6 Keep the Cutting Mat Clean and Sticky	46
2.01.7 Don't Get Frustrated, Get Help!	47
2.02 CHOICES BEFORE CUTTING	47
2.02.1 Controlling Which Shapes Will Cut	47
2.02.2 Controlling Where Shapes Will Cut.....	52
2.02.3 Selecting the Tool to be Used for Cutting	54
2.02.4 Determining the Cut Settings	55
2.03 CUT SETTINGS	57
2.03.1 Force	57
2.03.2 Cut Speed and Up Speed	57
2.03.3 Blade Offset	58
2.03.4 Overcut.....	59
2.03.5 Passes	59
2.04 PRESETS	62
2.04.1 Saving a Preset for a Blade Type	62
2.04.2 Saving a Preset for a Material.....	63
2.05 SETTING THE ORIGIN BEFORE CUTTING	66
2.05.1 Setting an Origin Using the Camera	67
2.06 OTHER CUT SETTING FUNCTIONS	69
2.06.1 Advance Mode	70
2.06.2 Mirror.....	70
2.06.3 Weeding Options.....	71
2.06.4 Weld Text.....	72
2.07 IMPORTANT CHECKLIST BEFORE YOU CUT!	73
2.08 SCALE CALIBRATION.....	73
2.08.1 Scale Calibration Using Millimeters for Measurement	74
2.08.2 Scale Calibration Using Inches for Measurement.....	77
2.09 TEST CUTTING FLOW CHART FOR THE SKYCUT.....	80
2.10 SETTINGS FORM FOR CUTTING MATERIALS	81
2.11 SUGGESTED SETTINGS FOR VARIOUS MATERIALS.....	82
3. PRINT AND CUT (CONTOUR CUT)	84
3.00 QUICK REFERENCE FOR CHAPTER 3	84
3.01 WHAT IS A PRINT AND CUT (PNC)?	84
3.02 WHAT IS A PNC CALIBRATION?.....	85
3.03 CAMERA CALIBRATION PROCEDURE FOR SKYCUT V.....	85
3.04 PERFORMING A PNC IN SIGNMASTER	88
3.04.1 Summary of Steps.....	88
3.04.2 Step-by-Step Simple PNC Project	88
3.05 PREPARING DESIGNS FOR PNC APPLICATIONS.....	93
3.05.1 Using Raster Images	93
3.05.2 Using Vector Images.....	93
3.06 INACCURATE CUTS	93
3.06.1 Inaccurate Tracings	94
3.06.2 Incorrect Cut Settings	94
3.07 ADDING REPEATS IN PRINT AND CUT APPLICATIONS	94
3.08 REGISTRATION MARK SETTINGS	97
3.08.1 Adding Intermediate Registration Marks.....	97
3.08.2 Registration Mark Types and Sizes	98
3.08.3 Mark Position (Offset Distance from Design).....	99
3.08.4 Page Marks Option	100
3.09 PNC FROM USB FLASH DRIVE	101
3.09.1 PNC from Flash Drive – Single Cut	101
3.09.2 PNC from Flash Drive – Using Array Mark for Repeats	104
3.09.3 Mark Set Options	106
4. ACCESSORY TOOLS AND DUAL HEAD CALIBRATION	109
4.00 QUICK REFERENCE FOR CHAPTER 4	109
4.01 DUAL HEAD CAMERA CALIBRATION	109

4.02 DRAWING WITH THE TEST PEN	112
4.02.1 Draw and Cut on the Skycut D.....	113
4.02.2 Draw and Cut on the Skycut V.....	116
4.03 EMBOSSING AND SCORING	120
4.03.1 General Info on Embossing	120
4.03.2 Score and Contour Cut Project on the Skycut D	120
4.03.3 Embossing Paper or Cardstock	126
4.04 SCRATCH ENGRAVING	126
4.04.1 Engraving a Metal Tag.....	127
4.05 SETTINGS FORM FOR ACCESSORY TOOLS.....	131
5. SIGNMASTER FUNCTIONS OF INTEREST	132
5.00 QUICK REFERENCE FOR CHAPTER 5	132
5.01 ADDING A CONTOUR CUT LINE TO AN IMPORTED RASTER IMAGE	132
5.01.1 Step-by-Step Tracing Process.....	132
5.01.2 Editing a Trace.....	136
5.02 ADDING A CONTOUR CUT TO A VECTOR IMAGE	138
5.02.1 Contour Cut Which Follows the Printed Design.....	138
5.02.2 Contour Cut Which Is Offset from the Printed Design	140
5.03 ENGRAVING FILL	143
5.03.1 Engraving File Module and Settings	143
5.03.2 Inside Fills Versus Outside Fills	146
APPENDIX A TROUBLESHOOTING FAQ'S.....	147
A1 COMMUNICATION ISSUES.....	147
A2 OPERATING ISSUES.....	148
A3 CUTTING/DRAWING ISSUES	150
APPENDIX B ORIGINAL CAMERA CALIBRATION.....	153
B1 CAMERA CALIBRATION PROCEDURE Video	153
B2 TWEAKING THE CALIBRATION VALUES	155
B3 DUAL HEAD CALIBRATION.....	157
APPENDIX C ACTIVATING COMMANDS.....	161

1. Introduction and Setting Up

1.00 Quick Reference for This Chapter

- How to download and set up SignMaster: *Section 1.11*
- How to set up communication between a computer and Skycut: *Section 1.12*
- How to use the control panel: *Sections 1.10 and 1.14*
- How to adjust the blade holder: *Section 1.07.5*
- Where to position the pinch wheels: *Section 1.09*
- The cutting mat is too sticky (or not sticky enough): *Section 1.08*
- How to use the USB Flash Drive feature: *Section 1.12.4*

Important Notes:

- Please read *Section 1.02* regarding safe operation of the Skycut.
- Report any damage or missing contents to your dealer promptly.
- Retain the original box and packing materials in case you ever need to ship your Skycut.

1.01 Support

- Thank you for choosing a Skycut digital die cutter. Before using a blade in your new cutter, we urge you to read *Chapters 1 and 2* and watch the videos linked in these chapters.
- If you run into difficulties with the operation of your Skycut, turn off the power and look for a solution in this manual. Note that *Appendix A* is a **Troubleshooting** section. If you continue to have technical questions or issues, please contact your dealer as soon as possible.
- If anything is missing from your order or you have mechanical issues with your Skycut, please contact your dealer as soon as possible. You can also contact Skycut directly using this email address: skycut@skycut.cn.
- For additional information and support with the Skycut, please check out the following:
 - ◇ Skycut web site: <https://www.skycutcutter.com/>
 - ◇ Skycut Facebook page: <https://www.facebook.com/skycutcuttingplotter/>
 - ◇ Skycut Facebook group: <https://www.facebook.com/groups/Skycut>
 - ◇ Skycut YouTube channel: <https://www.youtube.com/channel/UCrPn5hFLbiRNDgccY8iXwoA>
- For SignMaster support, please go to <http://signmaster.software/support/>

1.02 Safety and Warnings

Please be aware of the following safety guidelines when working with the Skycut:

- **Pinch Points:** Keep hands, long hair, loose clothing, jewelry, etc. away from the moving parts.
- **Risk to Children and Pets:** Please supervise children around the cutter when it is in use.
- **Movement and Touching:** Do not move the Skycut or touch any circuitry while it is plugged in.

- DO NOT touch or jam the plotter's track while it is operating. If the cutter is damaged, it is the owner's responsibility.
- DO NOT shake the cutter while it is operating.
- DO NOT cut any materials that have staples or other embellishments attached.
- DO NOT touch the cutter with a magnet. It is safe, however, to cut magnetic materials, such as those used on refrigerators and car exteriors.
- DO NOT allow any liquids to spill into the cutter.
- DO NOT allow small items to fall into the cutter.
- Place the Skycut on a sturdy and stable table, desk, or trolley. The optional Skycut stand can also be used.
- Always turn off the Skycut when not in use. Leaving the cutter turned on for extended periods of time can possibly damage the machine.
- Always turn off the Skycut before unplugging or removing the power cable from the wall outlet or power strip.
- Unplug the Skycut from a wall outlet or power strip during an electrical storm or when the cutter will not be used for an extended period of time.
- Transporting: When transporting the cutter, move the pinch wheel lever into the upward position. Remove the blade from the blade holder and cover the tip with the plastic cap.

1.03 Warranty









- ***IMPORTANT!*** If your Skycut is damaged during shipment or appears to be defective, your dealer should be notified as soon as possible.
- For additional information regarding your warranty, please refer to your Skycut dealer.
- It is recommended that you **retain the original box with packing materials** in case you ever need to ship your Skycut.

1.04 Unpacking

- Verify that you have received all contents. There is a checklist in *Section 1.05*. Please notify your Skycut supplier immediately if anything is missing.
- Remove all packaging before turning on the Skycut. Currently, the cutter ships with two end cap foam protectors, zip ties on either side of the blade carriage, and tape on either end of the cutting strip. **Be very careful when removing the zip ties – it's best to cut those ties from behind the machine versus in front.** Gently remove the tape at the ends of the cutting strip by rolling the tape away. Do not pull straight up.
- Because the cutting mat must be folded over to fit into the box, it may have become slightly rounded during shipping. Gently and only partially roll the mat in the opposite direction to remove the roundness and place on a flat table to make sure the mat now lies horizontally to the surface. Refer to *Section 1.08* for additional instructions on preparing the mat for use.
- Use the enclosed test pen as you experiment and become familiar with operating the Skycut. Place scrap paper on the mat and simply draw shapes rather than cut them. This will prevent possible damage to the blade, mat, and cutting strip as you learn where shapes will cut and the basic operating procedures.

1.05 Contents **Video**

- Besides the cutter, your box should also contain the following items:

#	Description	Image	Quantity (V model)	Quantity (D model)
1	Power cable		1	1
2	USB Cable		1	1
3	60° Blade(blue cap)		1	1
4	45° Blade(red cap)		2	2
5	Blade Holder		1	2
6	Test Pen and 1 Refill		1 set	2 sets
	Creasing Tool		0	1
7	Cutting Mat		1	1

1.06 Parts of the Skycut [Video](#)

Front

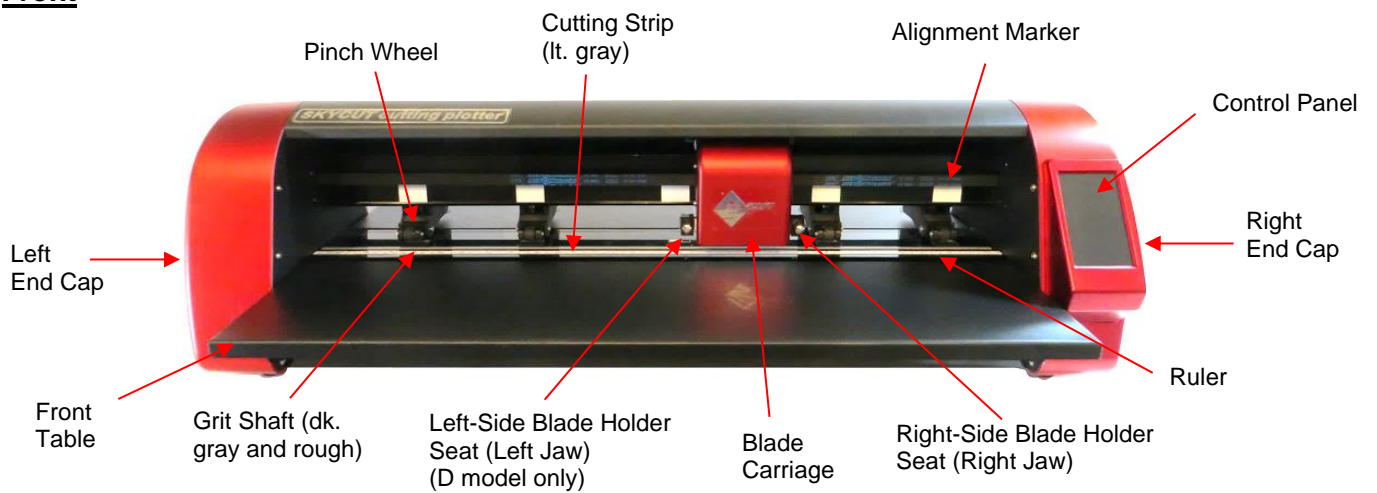

- Alignment Markers: indicate to the user the available positions for the pinch wheels
- Blade Carriage: moves the Blade Holder Seats left and right
- Blade Holder Seats or Jaws (2 on D models): hold the blade holder, test pen, and other accessories
- Control Panel: used to change settings, set up Wi-Fi, calibrate camera, cut PLT files, and more
- Cutting Strip: protects a blade when cutting backed materials without using a cutting mat
- Front Table (optional): keeps cutting mat supported horizontally
- Grit Shafts (5 on 24" model): allow the pinch wheels to grip the mat or material so they can be moved in and out of the cutter during cutting
- Pinch Wheels (4 on 24" model): grip the mat or material so that the grit shafts beneath will feed the mat or material in and out during cutting
- Ruler: for measuring and aligning rolled materials

Right Side



- USB Flash Drive Port: used to load PLT files via control panel for cutting
- USB Port: option to connect computer to Skycut with included USB cable
- Reset Button: used to reset Skycut's cutting buffer (does not reset calibrations)

Left Side



- Power Port: plug power cable into this port
- On/Off Switch: power cutter on or off

Back

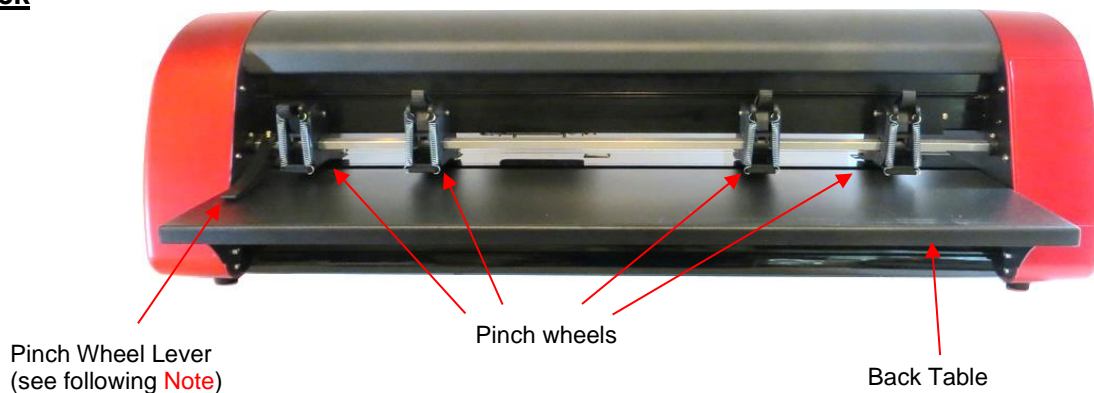

- Pinch Wheels (4 on 24" model): grip the mat or material so that the grit shafts beneath will feed the mat or material in and out during cutting
- Pinch Wheel Lever: raises and lowers the pinch wheels
- Back Table (optional): keeps cutting mat supported horizontally

Note: Newer models no longer have a single lever.

Each pinch wheel has its own lever to raise and lower.

1.07 Accessories

- Go to *Chapter 4* for details on using the engraving and scoring tools.

1.07.1 Assembling the Skycut D Stand (optional)

- If you purchased the optional stand, please refer to this [Video](#) for detailed instructions on assembling the stand and mounting the cutter onto it.

1.07.2 Tables (optional)

- The following instructions are for the original table design. If the tables you purchase have brackets that are not part of the table, please watch this video: [Video](#)
- While the two tables attach onto the cutter and do not require any support, you may prefer to not use them, especially if you are only cutting rolled materials. However, if you are using the cutting mat, the support they provide will keep the mat horizontal, thus reducing the chance of the mat drooping and causing materials to separate from the adhesive on the mat.
- The screws required for attaching are already installed in the Skycut. They will be removed and then, after aligning the holes in the table, replaced to securely attach the table.
- It's much easier to install if you have a second person available to hold the tables in place while the screws are being inserted. It is also helpful to have a flashlight shining on the inside of the tables to better see the holes for alignment.
- The two tables are identical. Start with either the front or the back of the cutter.
- There are a number of screws mounted on the inside of the end caps. The ones to be removed are the second and third from the bottom. They are also the only two with washers:

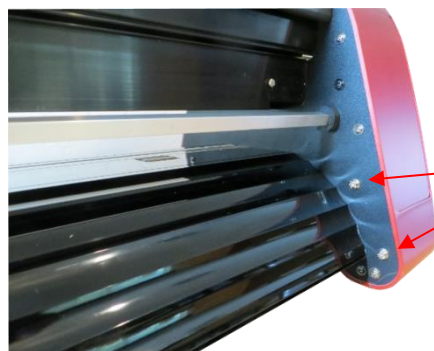

Remove these two screws from right-side end cap

Remove these two screws from left-side end cap

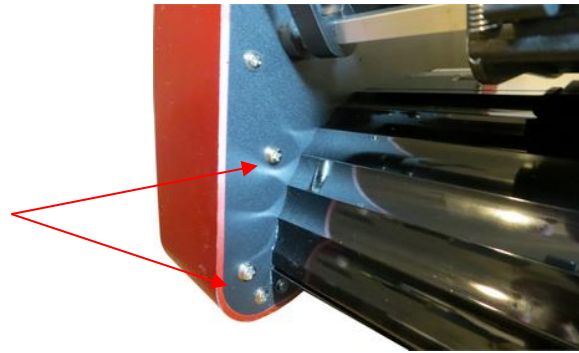

- Align the holes in the sides of the table with the holes in the end caps. Note in the following photos how the flat part of the table is on the outside:

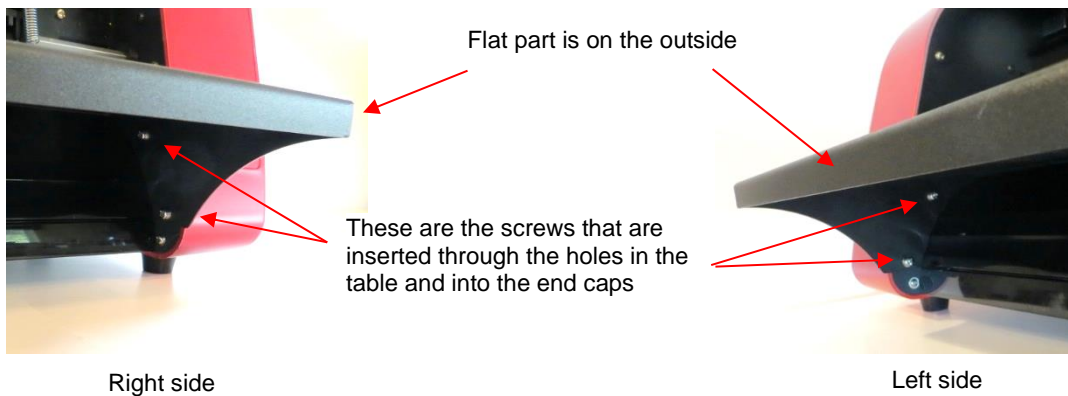

- Insert the screws previously removed through the aligned holes and screw back into place. Then repeat on the other side of the cutter.

1.07.3 Test Pen

- The test pen should be used until you are comfortable with the operation of your Skycut and know, with certainty, where images will cut. The test pen should arrive pre-assembled. However, if you want to change out the insert to the red ink insert, note how the test pen is assembled:



Spring goes over the top of the pen insert and stops at a small ridge on the insert

1.07.4 Skycut Blades

- There are three kinds of blades that fit inside the Skycut blade holder:



- ◇ The 45° **red** capped blade is suited for cutting thinner materials such as paper, all cardstock types, heat transfer vinyl, and wall/auto/decal vinyl.
 - ◇ The 60° **blue** capped blade is a much longer blade and is well-suited for cutting thicker materials, such as gum paste, craft plastic, craft foam, and rhinestone template material.
 - ◇ Sold separately is the 30° **yellow** capped blade. It is a wide blade and is well suited for cutting fabric, felt, and tint. It has been reported that it also works well with cardstock that has been exposed to humidity.
- Note that the red capped blade and blue capped blade have a cutback on the opposing side of the blade (right side, in the earlier photo). This reduces the blade offset value and allows for better detailed cutting of small shapes.
 - Additionally, there are other tools sold separately, including a stand, flatbed bolt-on tables, an engraving tool and a creasing/scoring tool. Details on the engraving tool and creasing tool (included with the D model) are covered in *Chapter 4*.

1.07.5 Blade Installation

- The blade must be carefully inserted into the blade holder. Do this over a soft surface (e.g. over a hand towel). It's important to protect the fragile blade! To install, follow the numbered steps as shown:

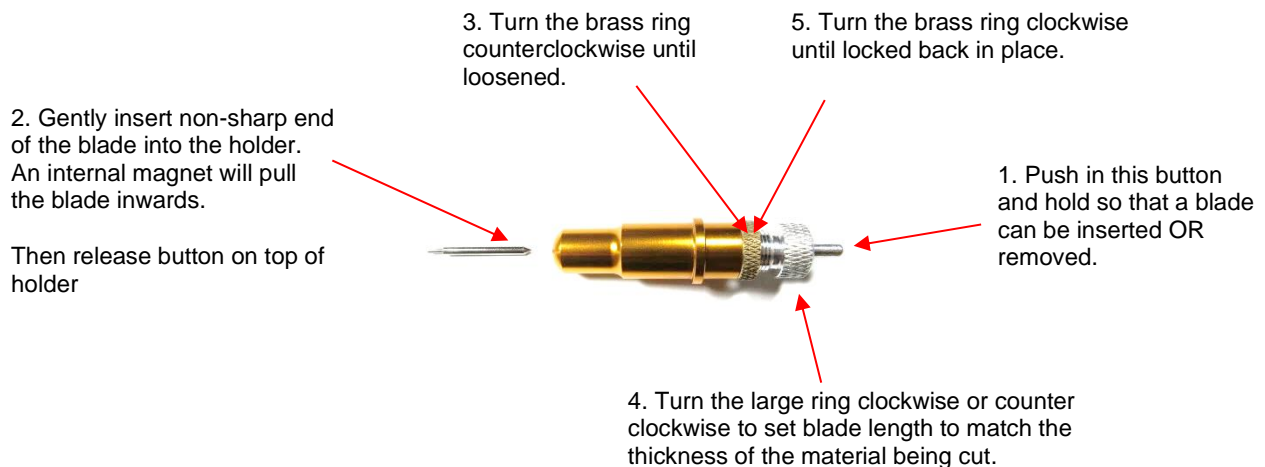

- The **Blade Length** (also called **Blade Exposure**) is how much blade is exposed at the bottom of the blade holder. For optimal cutting, you want this length to match the thickness of the material or be just a tiny bit longer.
- When setting the blade length (*Step 4* in the prior photo), hold the blade holder up next to the material before pressing the material to the mat, so that you can more accurately set the length to match the thickness of the material. For really thin materials, like vinyl and thin paper, just the very tip of the blade will be protruding from the bottom of the blade holder. In fact, you should just barely be able to feel it with your fingertip and not be able to see it very well, if at all. Having the blade fully extended will never result in better cutting. In fact, it can cause skewing, tearing of the material, damage to the blade, and damage to the mat or cutting strip.
- A good way to test your blade length is to fold a piece of the material onto itself and then cut a line into the material by hand. Press firmly but not too hard, as more force will not determine if the blade is set to the right length. If the blade cannot cut through the material, you will need to extend the blade. If the blade cuts through the material and cuts into the next layer, you need to retract the blade. If the blade cuts through the material but does not cut into the layer below, you have the perfect length.

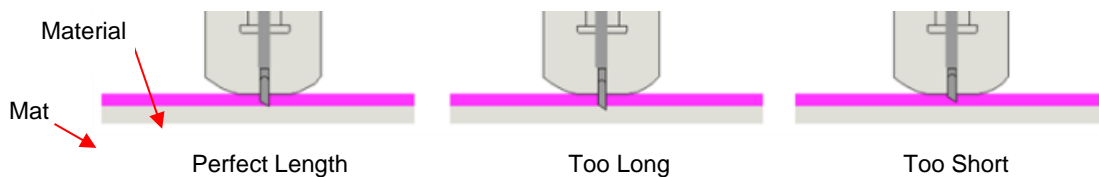

- When conducting a test cut, be sure to check your mat (or the top of a backing sheet) for cut lines after the test. You should be able to set the length to get clean cuts but with only fine lines or no lines in the mat or backing sheet. If you do see deep cut lines, retract the blade length $\sim\frac{1}{4}$ of a turn counterclockwise. Repeat your test cut.

1.08 Preparing and Caring for the Cutting Mat

1.08.1 Tips on Using the Cutting Mat

- Always use a mat to hold the material to be cut unless the material has its own protective backing. For example, vinyl and iron-on transfer both come with a layer that you do not cut. Thus, this backing layer serves as the carrier for cutting. Paper and cardstock do not have a backing, thus they must be cut on the mat.
- ***IMPORTANT!*** A new mat may be too sticky if you are cutting certain products. This can cause difficulty in removing cut items without tearing. Place an old but clean bath towel over the surface of the mat and press with a brayer or rolling pin. Then pull up. Test the stickiness by pressing the palm of your hand in the middle of the mat and lifting. If the mat remains stuck to your hand, repeat until the mat can still be lifted but will release. It should only take a few pressings to greatly reduce the stickiness, as tiny (too small to be visible) fibers from the towel are added to the surface.
- Do not leave the pinch wheels in a down position when the Skycut isn't in use. This warps the plastic sooner, shortening the useful life of the cutting mat.

1.08.2 Cleaning and Replenishing the Cutting Mat

- When mats begin to lose their stickiness, they can be washed:
 - ◇ Use a mild dishwashing detergent, warm water, and a soft brush to thoroughly clean the surface. You're not trying to scrub the adhesive but just wet the invisible fibers that have been deposited from your cutting materials and get them released from the glue.
 - Rinse well, shake off excess water, and place sticky side down onto a bath towel.
 - Thoroughly dry the non-sticky side of the mat with another towel.
 - Pull the mat up and the sticky side should now be dry enough for immediate use. Test by making sure the mat will stick to your hand.
- While washing with soap and water should revive the original adhesive, you can add more adhesive if necessary:
 - ◇ Virtually any repositionable adhesive may be used on the cutting mat. Some of the popular choices include: Krylon Easy Tack, Aleene's Tack It Over and Over (view the video at the start of this section), Crafter's Companion Stick and Spray, Zig 2 Way Glue with wide tip, Craft Smart Off 'N On, and Scotch Repositionable Craft Stick. There's another spray adhesive, Scotch Super 77, which does not leave a sticky surface but is excellent for stabilizing paper and cardstock.
 - ◇ If you are cutting thicker materials, such as oil board or styrene, then you may want to experiment with a stronger adhesive and use painter's tape to secure the material to the mat. If you are cutting thin paper, then you may want to experiment with a lighter adhesive.

- ◇ With most repositionable adhesives, you can control the tackiness based on the amount applied. Thus, always add a little bit at a time. As mentioned above, if you add too much, just apply a layer or two of cotton fibers by pressing with a bath towel.
- Other reported methods for cleaning mats:
 - ◇ Use a plastic scraper (an old credit card will suffice) to scrape off any random material pieces remaining on the mat after a cut.
 - ◇ For finer particles of paper or lint, you can use a lint roller. Tear off a sheet and then press down and pull up across the surface of the mat to clean in sections. Baby wipes can accomplish the same task.
 - ◇ To completely remove adhesive from the mat, apply Goo Gone, Duck Adhesive Remover, or Avon's Skin So Soft Bath Oil across the surface. Allow a minute to soak in and then scrape off with a sharp metal spatula. Repeat, as necessary until the mat is thoroughly clean and no longer sticky. Wash, dry and then add any repositionable adhesive.
- When necessary, the rubber wheels and the grit shafts may be cleaned with isopropyl alcohol or Un-Du. Apply the cleaner to a clean lint-free rag and rub the entire wheel and/or grit shaft until free of adhesive.

1.09 Pinch Wheels

1.09.1 Raising and Lowering

- The pinch wheels can be raised (for loading the material and/or mat) and lowered (for cutting). Depending on when your Skycut was manufactured, the method for this is different.

Newer Model Pinch Wheels

- If you do NOT have a single pinch lever, press down on an individual lever on a pinch wheel so that it can grip the mat or material. Lift up an individual lever to raise that pinch wheel.

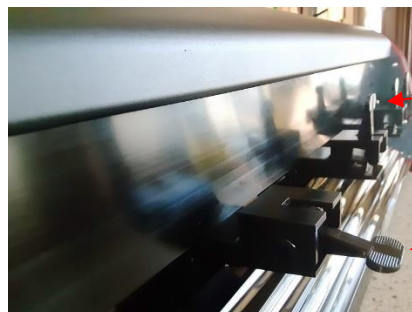

Pinch wheel is in the up position.

Pinch wheel is in the down position.

Older Model Pinch Wheels

- If you have a single pinch lever located at the back-right side of the machine, press down on that lever and the pinch wheels will be raised. Pull the lever up to lower all pinch wheels so that they can grip the mat or the material inserted into the cutter. ***IMPORTANT:*** Always hold the lever while raising and lowering. Never allow the lever to pop up on its own as this can put a lot of stress on the two couplers gripping the pinch wheel bar in the back.
- *On the single pinch wheel lever models only*, there is also a small black lever on each individual pinch wheel. When the lever is raised, there is more downward pressure exerted. ***IMPORTANT:*** Only push these small levers up when an extra tight grip is needed, such as when cutting reflective film or thick chipboard. For normal cutting of most materials, it will not be required.

Lever is in down position. This is recommended for most cutting.



Note: These two photos ONLY apply to the single pinch wheel lever model.



Lever is in up position. Do NOT use this position except with certain materials.

1.09.2 Pinch Wheel Locations

- Note that for a pinch wheel to grip properly, it must be positioned over a grit shaft. To facilitate alignment, note the white rectangles positioned along the horizontal bar behind the blade carriage. Slide the pinch wheels along the bar, as needed:

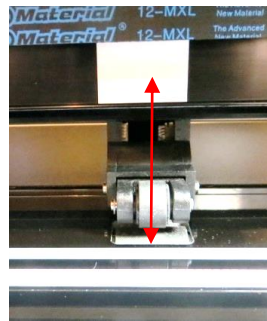

Wheels should be centered over grit shafts which are directly below the white rectangles

- When using the cutting mat, it is recommended that the material be placed in the middle of the mat and the mat placed roughly in the middle of the cutter. Then use the second and fourth pinch wheel locations for two pinch wheels. This keeps the pinch wheels off the material and provides an equal balance while the mat moves in and out during cutting:

Middle two pinch wheels are placed under 2nd and 4th white rectangles



Pinch wheels are approx. the same distance from the outside edges of the cutting mat

- Note that if your material is very wide, then it is fine to have the pinch wheels over the material. However, you may need to be extra careful when removing any cut shapes or waste material in those locations.

1.10 Control Panel

- When you first turn power on the Skycut, after several seconds, the following **Main Screen** or **Home Screen** will be displayed:

Repeat last cut. While cutting, this icon and function changes to **Pause**. 

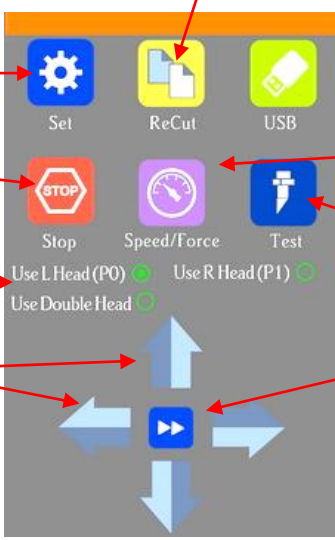

Change settings Refer to 1.10.1

Stop and cancel the current cut

Select which head to use or select **Double Head**

4 arrow keys for moving the head left/right and for moving the pinch rollers

Open and cut PLT files from an inserted USB flash drive

Set the desired speed and force.

Execute a test cut using current speed and force settings

Toggle the speed for moving the head and pinch rollers. In slow mode, the icon changes to: 

- Throughout this manual, the functions above will be referenced along with submenus and additional screens. You will also see the following icons at the bottom of many screens. Pressing the one on the left will always return you to the **Main Screen** above. Pressing the one on the right will return you to the prior window/screen.

Go back to **Main Screen/Home Screen**   Go back to prior screen

1.10.1 Set Screen

- Pressing the **Set** icon  opens the **Set Screen** which contains access to many functions and settings. Note the general description and section number (if you wish to learn more about that function now):



Calibrate and use camera for print and cut applications: *Chapter 3*

Set end-of-cut options: *Section 2.06*

Settings for: LED, Units, Language, Screensaver, Alarm: *Section 1.14.2*

Set up wireless connection to home or office network: *Section 1.12.2*

Array setup, Scale, and options for display and cutter behavior: *Section 1.14.2*

Version numbers, software selection, reset: *Section 1.14.3*

1.11 Registering and Installing SignMaster

1.11.1 Installing from a Download

- Once you have purchased a registration for SignMaster, the software can be downloaded from the following link. It's important to use this link so that the Skycut will be installed as the cutter of choice. You will need your **Product Serial Number** that was sent to you. Since you'll also need this number every time you update the software, keep this number in a safe place.

<https://signmaster.software/smc.htm>

- Note where the file will be saved on your computer so that you can later browse to that folder and launch the .exe file which has been downloaded. Follow the steps in the following *Section 1.11.2*, starting with *Step (4)*.

1.11.2 Installing from a CD

- Remove the CD from the case and insert into the CD ROM drive on your computer.
- The downloaded file is in .exe format, thus ready to launch.
- If Windows Autorun does not initiate a welcome screen, use Explorer to locate and click on the DVD drive letter for your computer. Double click on the *Welcome* file and the following window will open:

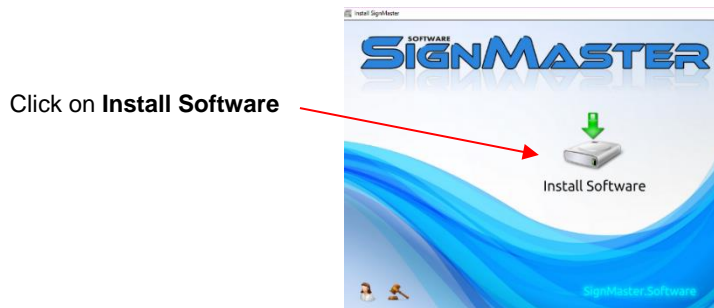

- Click on **Install Software** and wait for the installation program to open. Select the language you prefer:

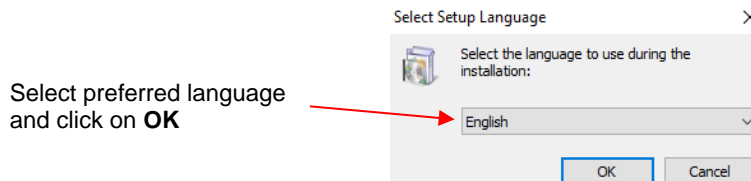

- Read and accept the license agreement:

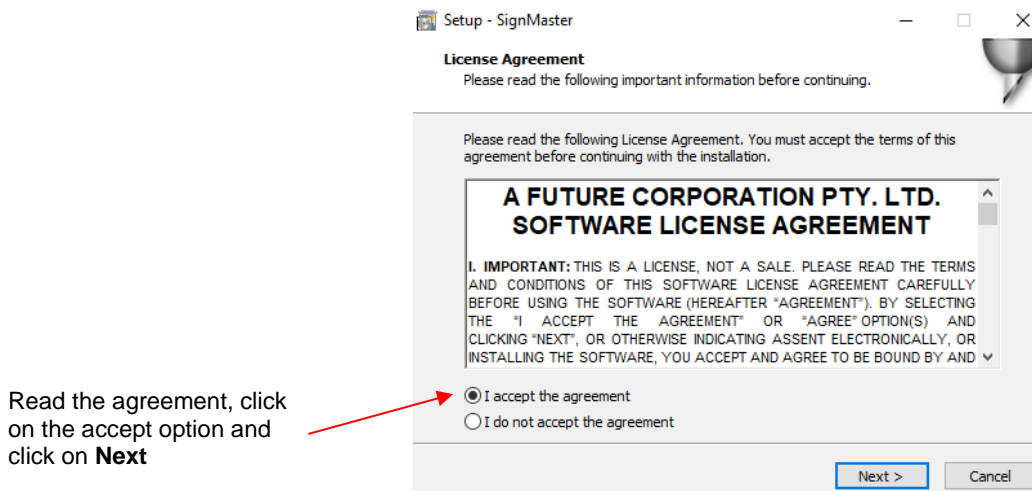

- (6) Enter the **Product Serial Number** which should have been sent to you by email when you purchased SignMaster. Note that since you will need this same number any time you update the software, keep it in a safe place:

Enter the 20-digit **PSN** provided when you purchased SignMaster and click on **Next**

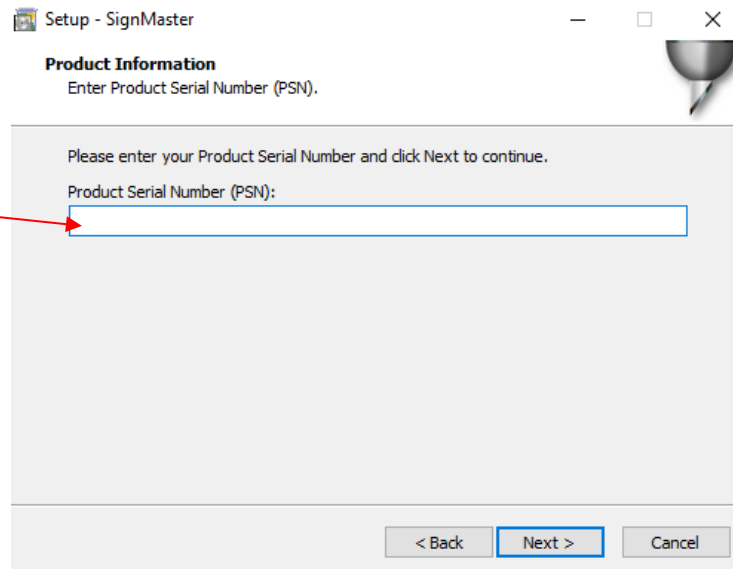

- (7) Read and accept a second license agreement and then verify the destination for installing SignMaster:

Note where the program will be installed and click on **Next**

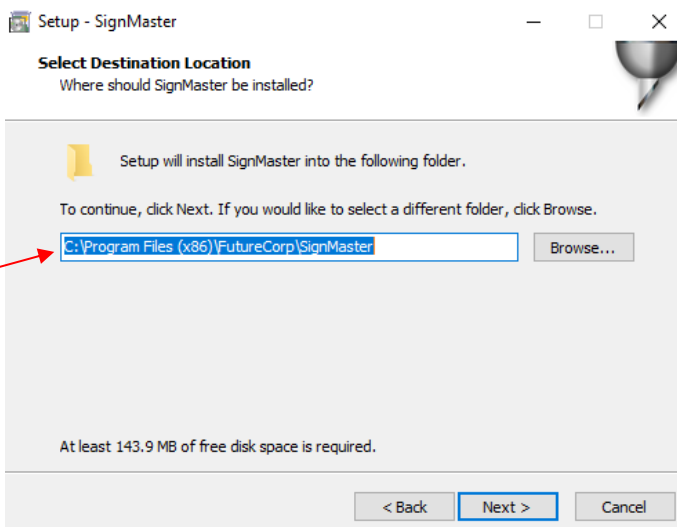

- (8) Select your preferred **Units** but note that it can easily be switched once the software is open:

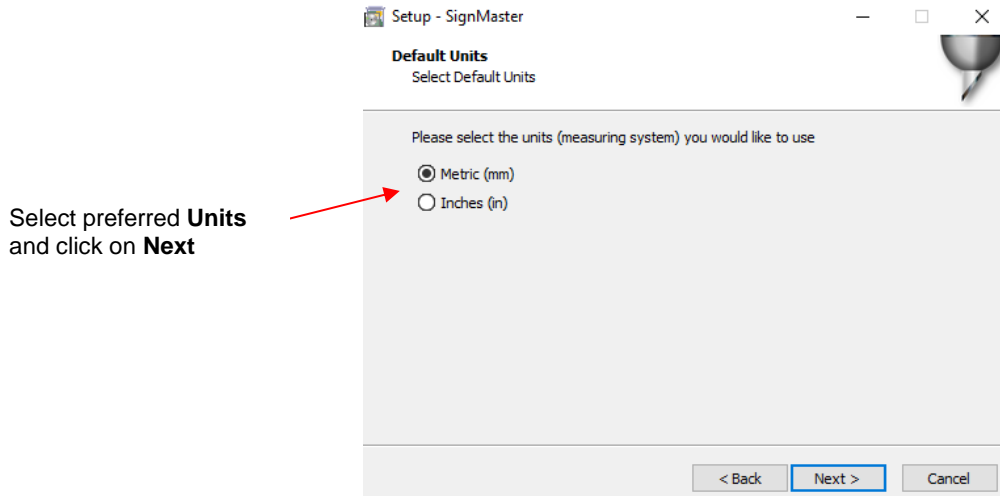

Select preferred **Units** and click on **Next**

(9) Select **SKY CUT D24** (or the model you have purchased) from the drop-down menu:

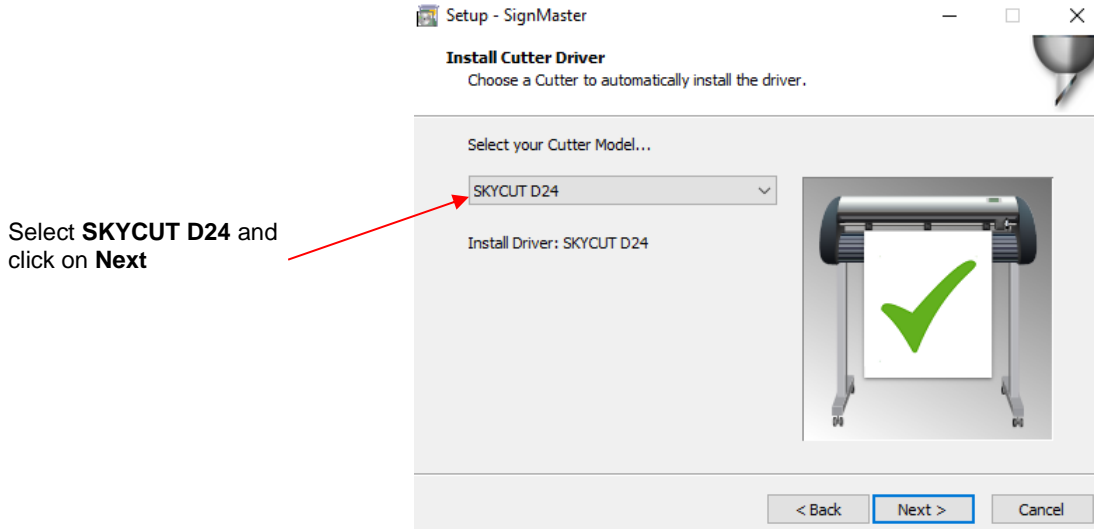

Select **SKY CUT D24** and click on **Next**

(10) In the next window, you'll have the option to create a desktop icon and install a thumbnail previewer. Both are recommended.

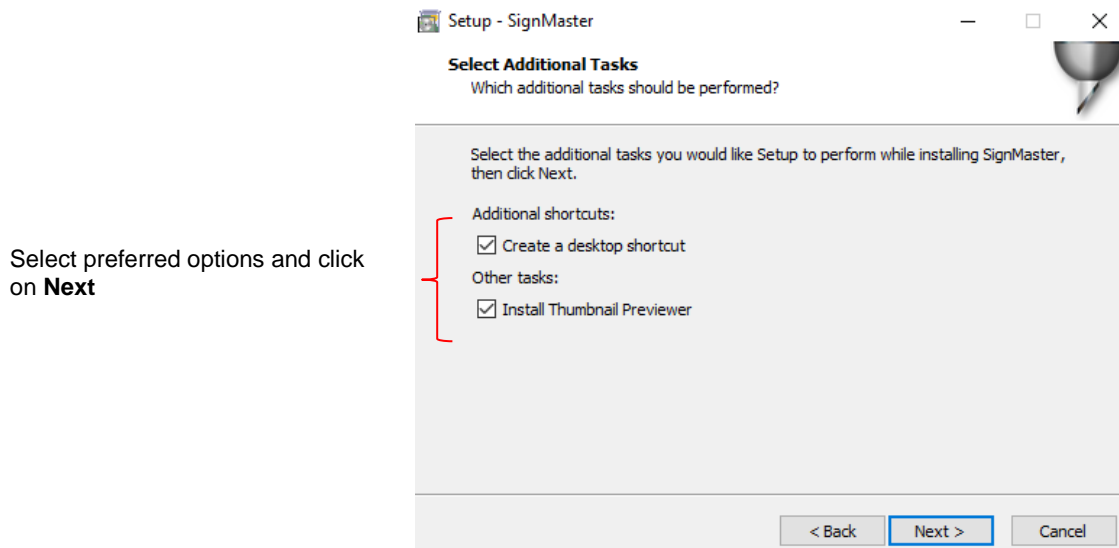

Select preferred options and click on **Next**

- (11) At this point, files will be extracted and installed. Wait for the **Installation Complete** message and click on **OK**:



- (12) Then the final **Finish** message will appear and you can choose to open SignMaster or wait:



- If you run into any issues installing or activating the program, please visit this link:
<http://www.iifuture.net/faq/index.php?action=show&cat=44>
- You may wish to periodically visit the link provided for SignMaster at the beginning of *Section 1.11.1* to download and install any new updates.

1.12 Connecting the Skycut to Your Computer **Video**

- Place your Skycut on a sturdy horizontal surface. If using the cutting mat, be sure to allow enough free room in both the front and the back for the mat to extend during cutting.
- Powering On:
 - ◇ Plug the power cord into a wall outlet or power strip. Connect the power cord to the Skycut on the left side end cap.
 - ◇ Turn on the power using the power button that is also on the left side end cap. After several seconds, the light inside the Skycut will turn on and the head will do a slight jog.
- You have four options for sending files and information from your computer to the Skycut:
 - ◇ **Direct USB** using the included USB cable
 - ◇ **Wi-Fi** – adding the Skycut to a home/office network that is also accessed by your computer
 - ◇ **Wireless Standalone** – connecting wirelessly to your computer
 - ◇ **U_Disk** - Exporting PLT files from SignMaster onto a USB flash drive and then loading those files using the control panel on the Skycut.
- Review the information in the following table to understand the differences between these options. Note that implementing any of these options does not preclude you from changing to another one, as needed.

Connection Options for the Skycut

<u>Option</u>	<u>USB</u>	<u>Wireless to Network (Wi-Fi)</u>	<u>Wireless Stand-Alone</u>	<u>USB Flash Drive</u>
<u>Description</u>	The Skycut is connected to the computer via a USB cable	The Skycut is wirelessly connected to a network router	The Skycut is wirelessly connected to the computer.	Files are saved in PLT format from SCAL to a USB flash drive
<u>Requirements</u>	USB cable (included)	Wireless network router and knowledge of router's name and password	Computer must have wireless capability	USB flash drive
<u>Pros</u>	Easy to install; Reliable and fast form of communication.	Skycut can be located anywhere within range of the router; Other computers can cut to the Skycut	Skycut can be located anywhere within range of the computer; Other computers can cut to the Skycut	Skycut can be located anywhere
<u>Cons</u>	Skycut is physically connected to the computer; Cannot be accessed by other computers at the same time	Requires more steps to set up; Some routers may require setting changes in order to work with the Skycut	Computer is now connected to the Skycut, thus no <u>wireless</u> access to the Internet or to other wireless devices	More steps due to saving and then loading the file; Cannot adjust size and certain cut settings once saved

- The following sections present what steps are required for each type of connection. If you run into connectivity issues, please contact your dealer.

1.12.1 USB Connection

Video

- Plug the small square end of the USB cable into the right end cap of the Skycut D. Plug the USB end into an available USB port on your computer.
- In SignMaster, click on the **Cut, Plot & Engrave Tools** icon  (6th from the left on the upper middle task bar) and select **Vinyl Spooler**. In the window which opens, click on the **Connection** tab.
- Verify that **Skycut D24** (or the model you have purchased) is selected under **Current Cutter**. If not, select it from the drop-down menu. Under **Port Type**, select **Direct USB Port**. In the drop-down menu next to **USB Port**, select an option that contains the word "skycut":

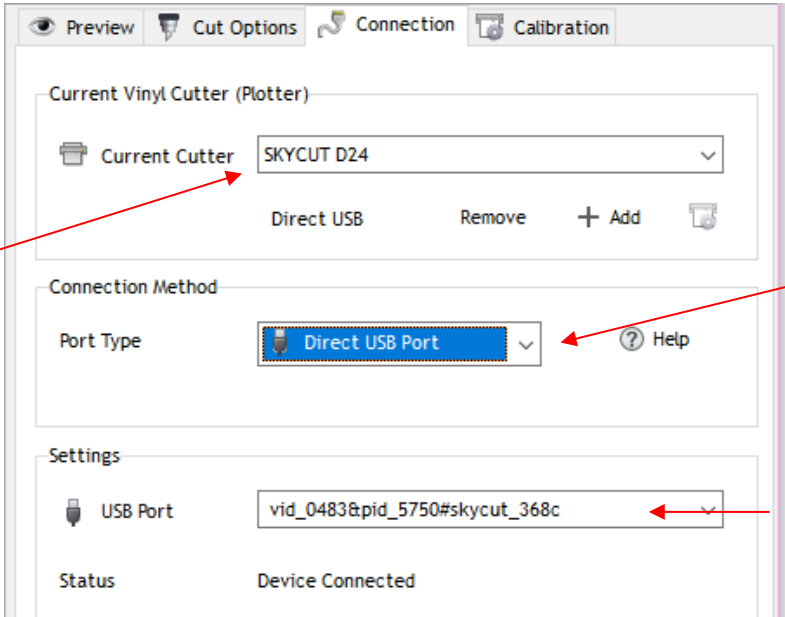

Should read **SKYCUT D24** (or the model you have purchased)

Select **Direct USB Port**

Look for and select an option with "skycut" in the name

- If a USB Port option cannot be located, verify the connection at both the cutter and on the computer. Once connected, click on **Done** at the bottom of the window and proceed to *Section 1.13*.

1.12.2 Wi-Fi Connection Video

- Note: Not all routers have the same signal strength. It's usually best to connect the Skycut while it is in the same room with the router. Once connectivity is established, you can then experiment to see how far from the router the Skycut can be located.
- What you'll need:
 - ◇ Name of your home/office network
 - ◇ The password for your network
- Carefully complete the following steps:

(1) On the Skycut's control panel, select **Set**  and then select **Wifi**. The **Wifi** screen will appear:

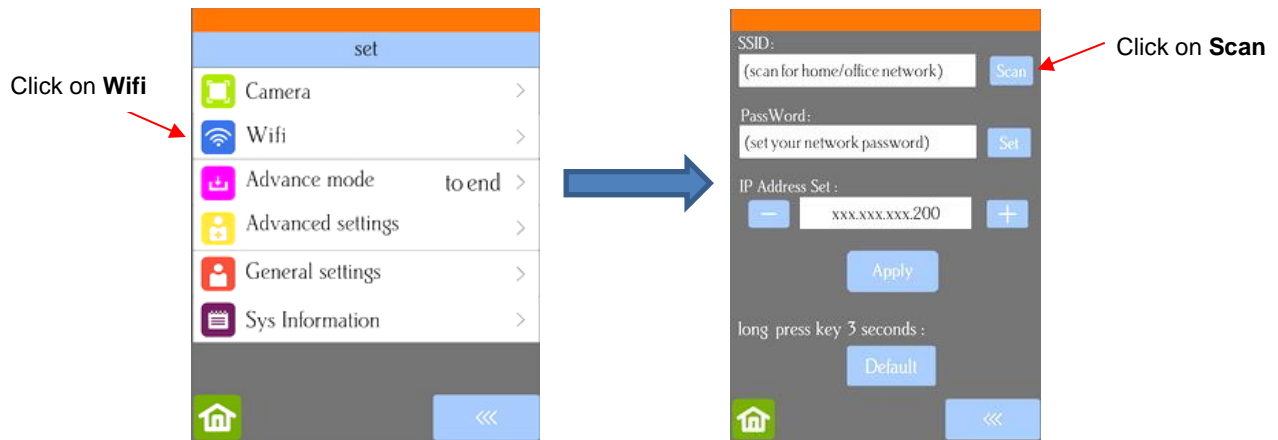

(2) Click on the **Scan** button and a list of the available networks will appear. Select your home/office network and click on **Apply**. You will then be returned to the **Wifi** screen:



(3) Click on **Set** and the following screen will open:

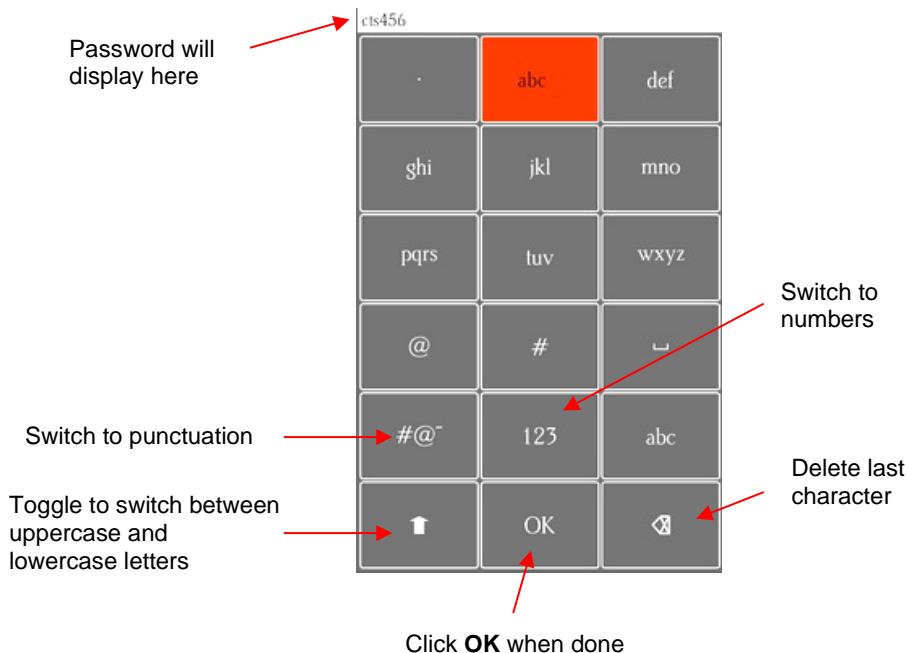

(4) To enter the password, use the following tips if you are unfamiliar with this type of screen:

- ◇ “Rapid tap” multiple times in succession to select a letter. For example, if your network password is *cts456*, then to enter “c”, you would tap three times on “abc” because “c” is the third letter in “abc”. Next you would proceed to “stu” and tap two times to enter “t”. Then you would only need to tap on “stu” once to enter the letter “s.”
- ◇ To enter numbers, click on “123” to open the number entry screen.
- ◇ For punctuation, click on “#@~” to open the extra characters screen.
- ◇ To enter upper case letters, click on the up arrow in the lower left part of the screen.

(5) Once you have the password entered in the display box at the top, click on **OK** to return to the **Wifi** screen:



- (6) Next check the **IP Address** that will be assigned to the Skycut. The Skycut will automatically pick up the first three sets of digits from your router but will continue to display them as shown above. You only need to decide if the last set, which should be defaulting to “200”, can be used. Use the “+” or “-” buttons to make any needed changes.
- (7) Click on **Apply** and wait for several minutes while your router assigns this **IP Address** to the Skycut. Eventually, you will see **Connected OK** appear:



- (8) If instead of receiving a **Connected OK** display, you see **Password err**, again verify the network you selected and the password you entered. If you are unable to successfully connect and the Skycut is within a few feet of your router, please check your router's user manual and/or search online for issues with your particular router model.
- (9) If you wish to reset and start again, press and hold the **Default** button for 3 seconds until the button turns red. Then click on **Scan** and repeat from *Step 3*.

- Once you receive the **Connected OK** display, in SignMaster, click on the **Cut, Plot & Engrave Tools** icon  (6th from the left on the upper middle task bar) and select **Vinyl Spooler**. In the window which opens, verify that **Skycut D24** is selected under **Current Cutter**. If not, select it from the drop-down menu. Under **Port Type**, select **Windows Port**. Mark the option for **Port** and select **TCP** from the drop-down menu:

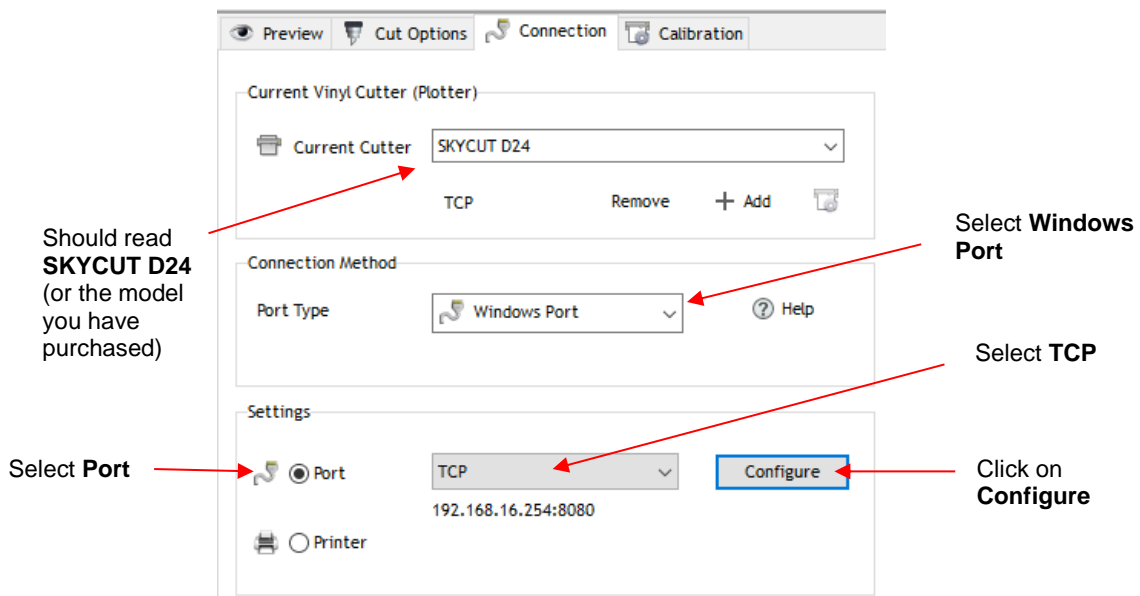

- Click on **Configure** and the following window opens:

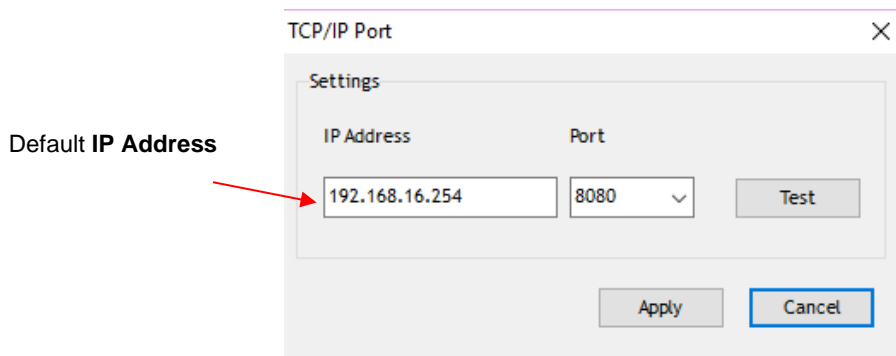

- Change the **IP Address** to the one you set up on the Skycut control panel. Click on **Test**. A **Port OK** message should pop up. Click on **OK** and then click on **Apply**:

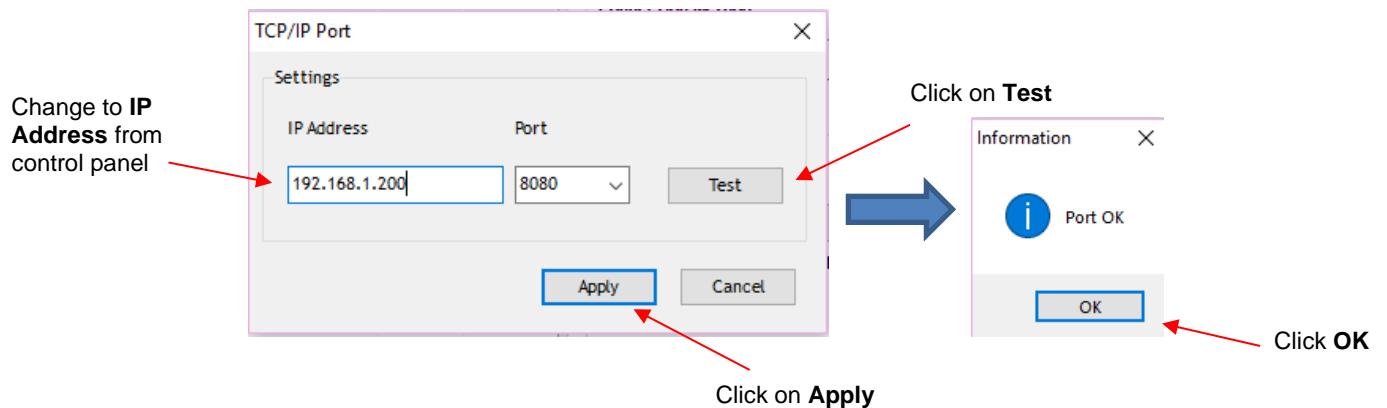

- The **IP Address** should now appear in the **Vinyl Spooler** window:

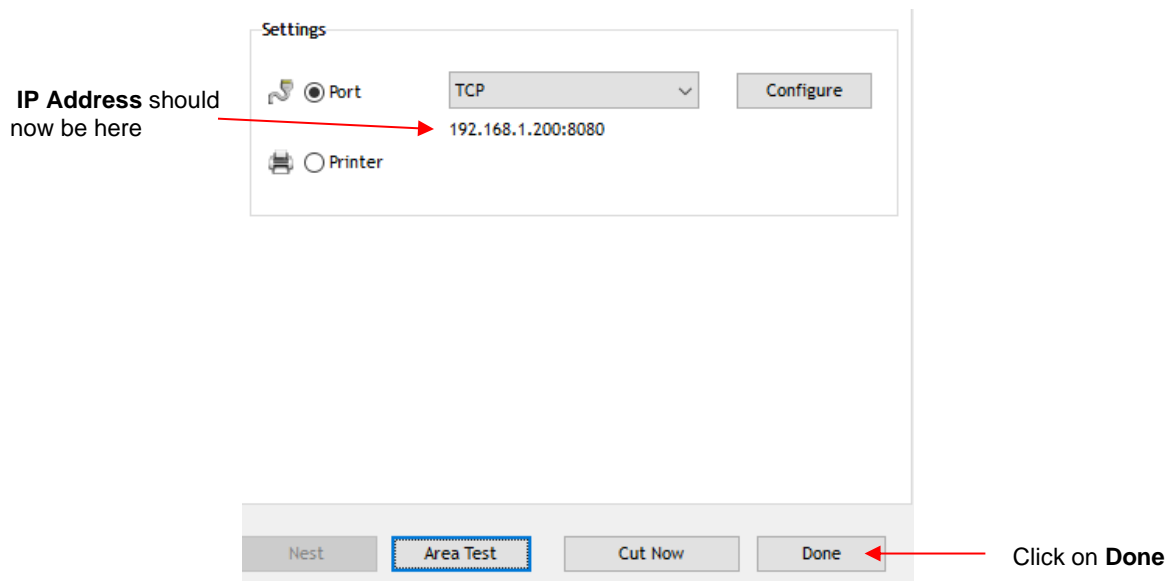

- Click on **Done** and proceed to *Section 1.13*.

1.12.3 Wireless Stand-Alone

- It's usually best to connect the Skycut while it is next to the wireless computer. Once connectivity is established, you can then experiment to see how far from the computer the Skycut can be located.

- There are two situations to consider before getting started. If you are not sure which applies to your Skycut, then select *B* and go to that section first.
 - A. The Skycut has never been set up wirelessly to a network.
 - B. The Skycut has previously been connected to a wireless network.

A. The Skycut has never been set up wirelessly to a network

- Power on the Skycut and wait for the light to come on.
- On your computer, open your list of available networks. In the list, you should see one with this type of name format: *HI_LINK_XXXX* where “XXXX” can be any alphanumeric combination, such as “92BF” or “08A5”.
- Select that network and enter the following **Network Key** when prompted: 12345678.
- In SignMaster, click on the **Cut, Plot & Engrave Tools** icon  (6th from the left on the upper middle task bar) and select **Vinyl Spooler**. In the window which opens, verify that **Skycut D24** is selected under **Current Cutter**. If not, select it from the drop-down menu. Under **Port Type**, select **Windows Port**. Mark the option for **Port** and choose **TCP** from the drop-down menu: **Configure** button.

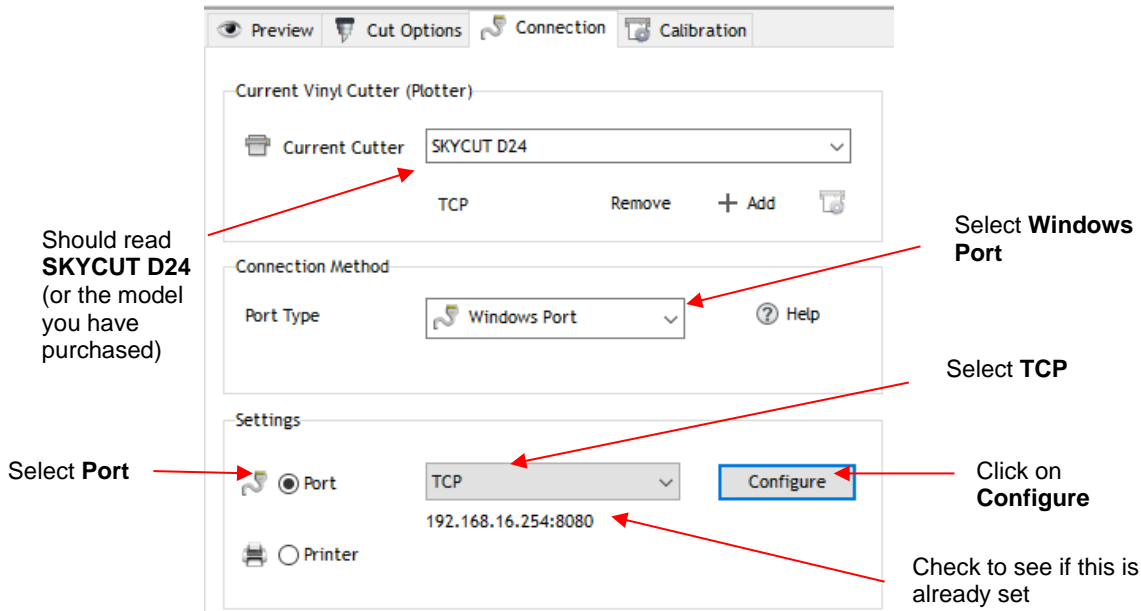

- In the prior screenshot, the **IP Address** is already set to the correct **Stand-Alone IP Address**: 192.168.16.254. If this matches what you see, skip the next two steps. Otherwise, click on **Configure** and the following window opens:

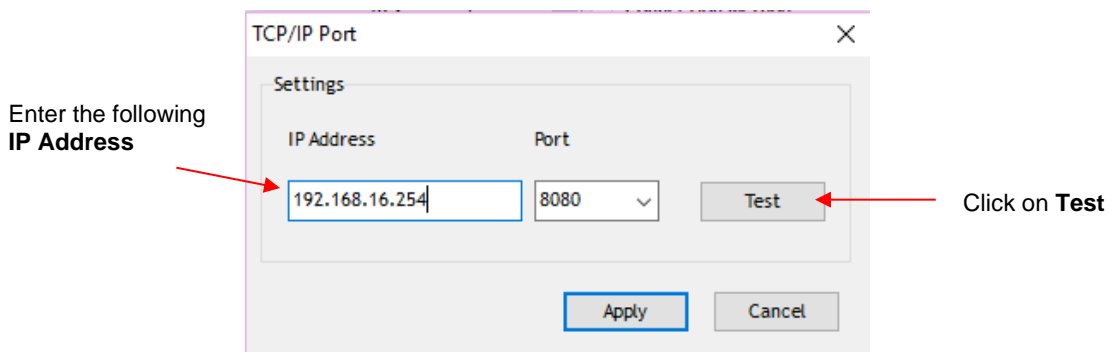

- Change the **IP Address** to 192.168.16.254. Click on **Test**. A **Port OK** message should pop up. Click on **OK** and then click on **Apply**:

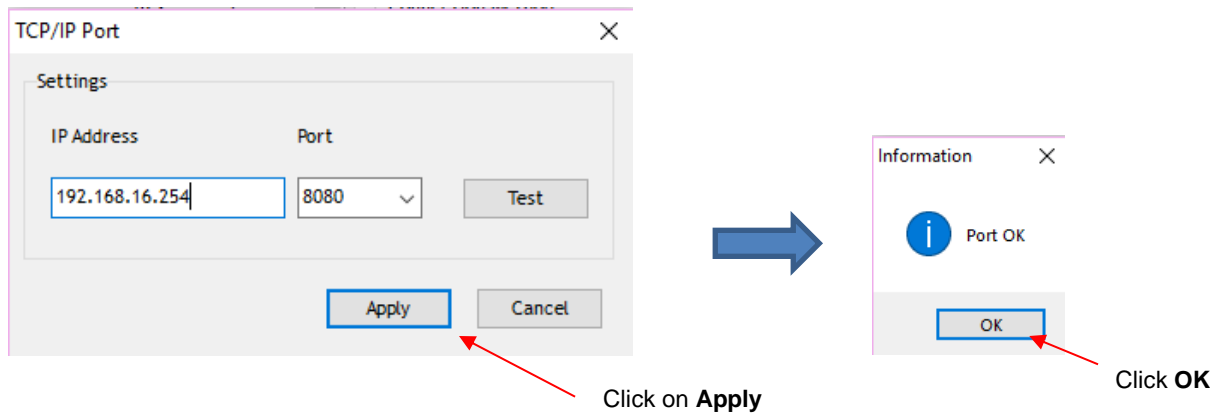

- The **IP Address** should now appear in the **Vinyl Spooler** window. Click on **Done** and proceed to *Section 1.13*. Remember that your computer will not have access to the Internet or other network devices while in **Wireless Stand-alone** mode.

B. The Skycut has previously been connected to a network

- On the Skycut's control panel, select **Set**  and then select **Wifi**. The **Wifi** screen will appear:

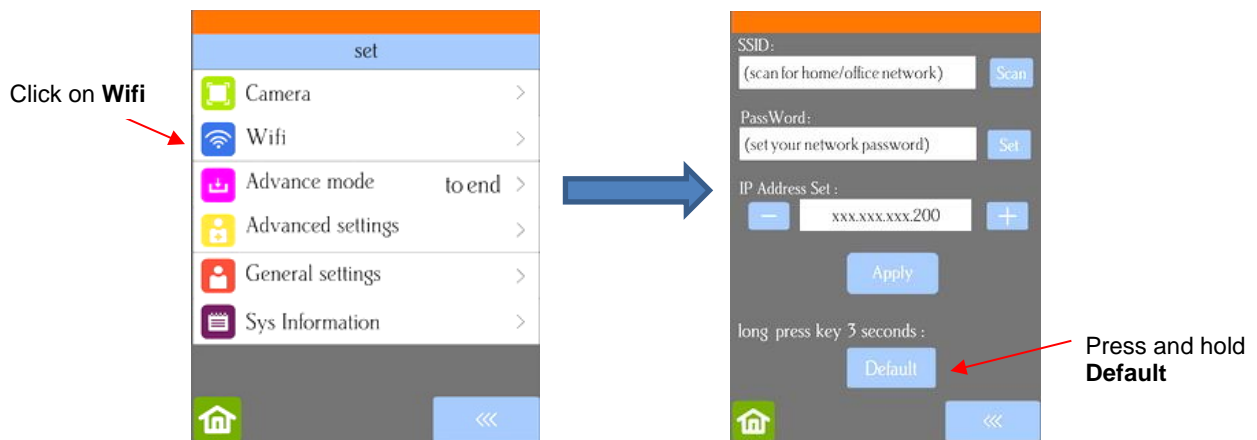

- To reset the Skycut so that it will be found as an available network, press and hold the **Default** button for 3 seconds. Release and you should see the **Apply** button now displays **Wait**. In a minute the **Apply** should return and you can then proceed back to A. The Skycut has never been set up wirelessly to a network and use the same procedure as if the Skycut was never set up on a network.

1.12.4 USB Flash Drive Video

- With a USB Flash Drive connection, you will normally follow the steps presented in this section. If you are new to SignMaster and/or to your Skycut, it is recommended that you go to *Section 1.13* now to learn how to insert the mat and test pen, adjust settings on the control panel, and set up a test design. Then, when you are ready to cut, return to this section.
- Design or open a file in SignMaster. After making any changes to the design, click on the **Cut, Plot &**

Engrave Tools icon  (6th from the left on the upper middle task bar) and select **Send to Cutter**. The following window opens:

Click on **Properties** to open **Vinyl Spooler** window

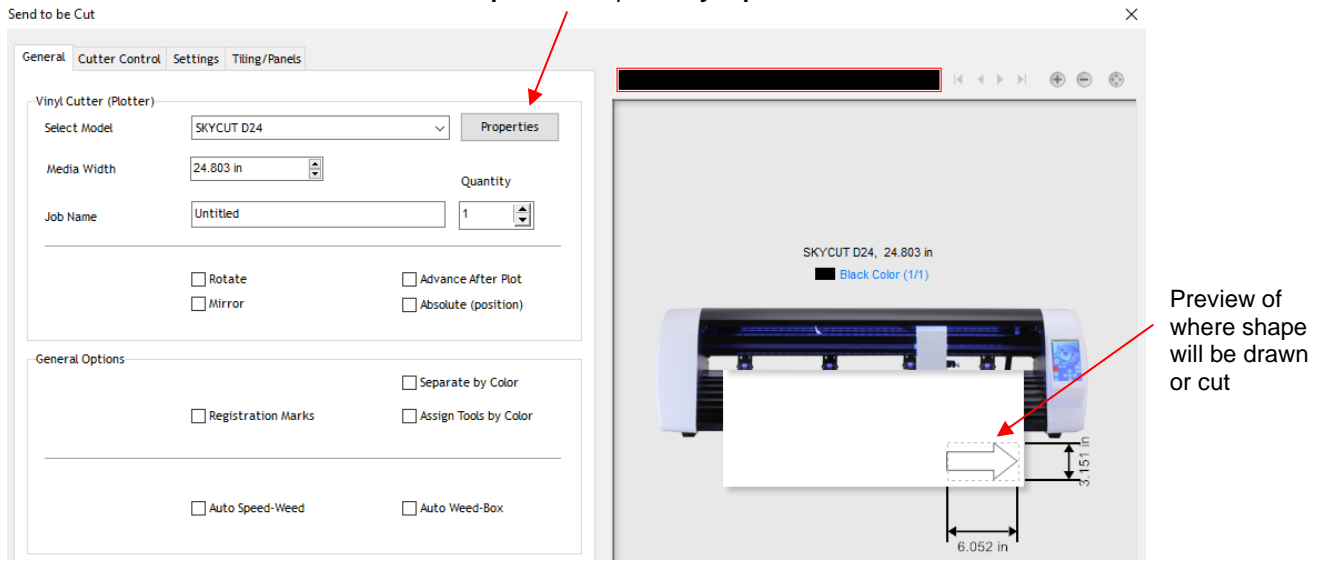

- Click on the **Properties** button to open the **Vinyl Spooler** window. The **Cut Options** tab should automatically be selected. Verify that the **Pen Tool** is selected (assuming this is your first time testing your Skycut). Also verify that the force and speed settings are not marked. At the current time, it is recommended that you always do these settings on the Skycut's control panel, instead:

Select **Cut Options** tab

Pen drawing: leave unchecked; Cutting: Check and enter settings

Uncheck all three of these settings

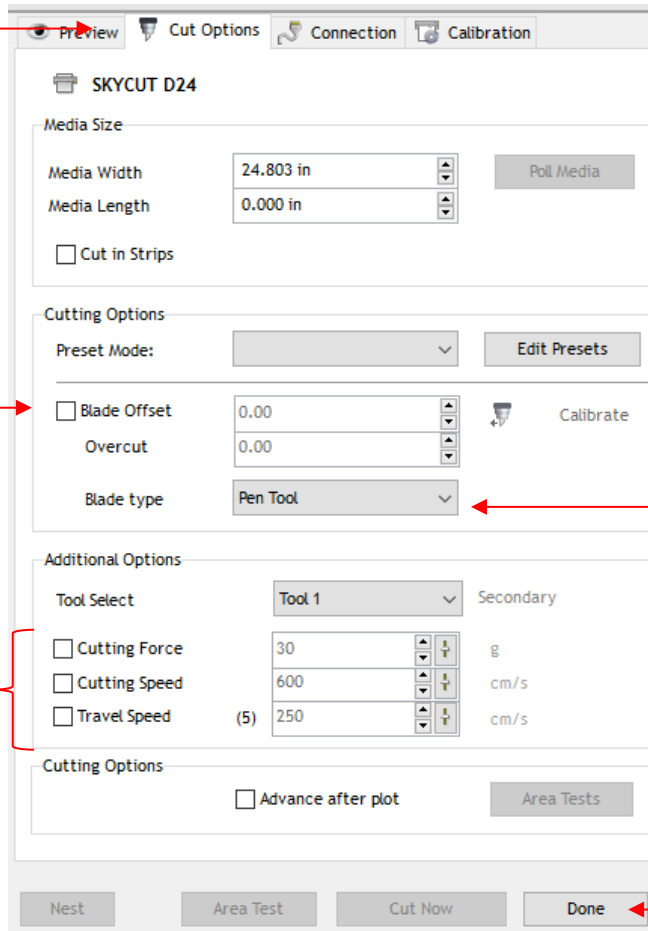

Pen drawing: select **Pen Tool**
Cutting: select blade type from menu

Click on **Done**

- IMPORTANT:** For initial testing of your Skycut, it is highly recommended that the test pen be used until you know, with certainty, where shapes will draw.

- Click on the **Connection** tab and verify that **Skycut D24** is selected under **Current Cutter**. If not, select it from the drop-down menu. Under **Port Type**, select **Windows Port**. Mark the option for **Port** and then select **U_Disk** from the drop-down menu:

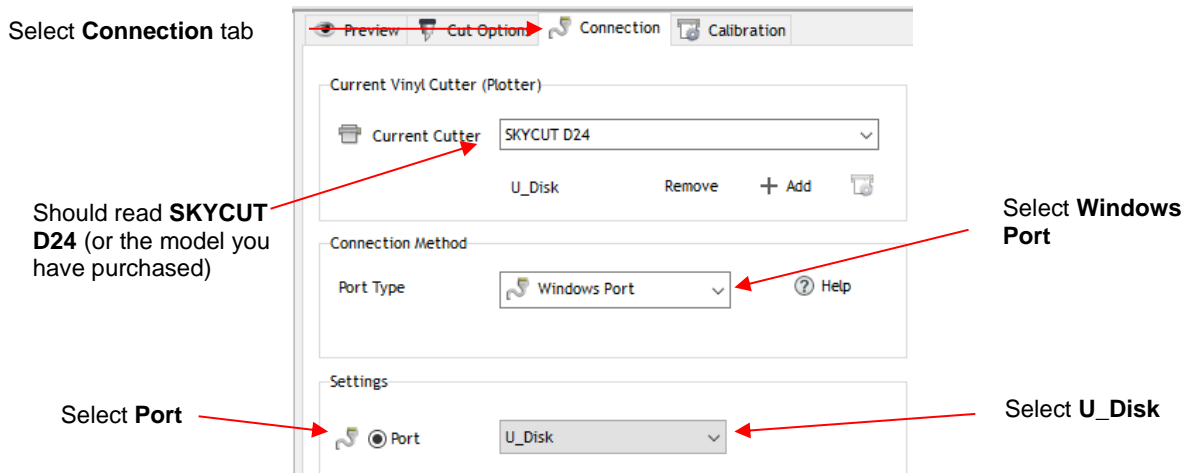

- Click on **Done** at the bottom of the **Vinyl Spooler** window and you will be returned to the **Send to be Cut** window. More about the settings on the left side of the window will be covered in *Section 2.03*. For now, just note where your shape will draw relative to the material and how to initiate the exporting of the PLT file:

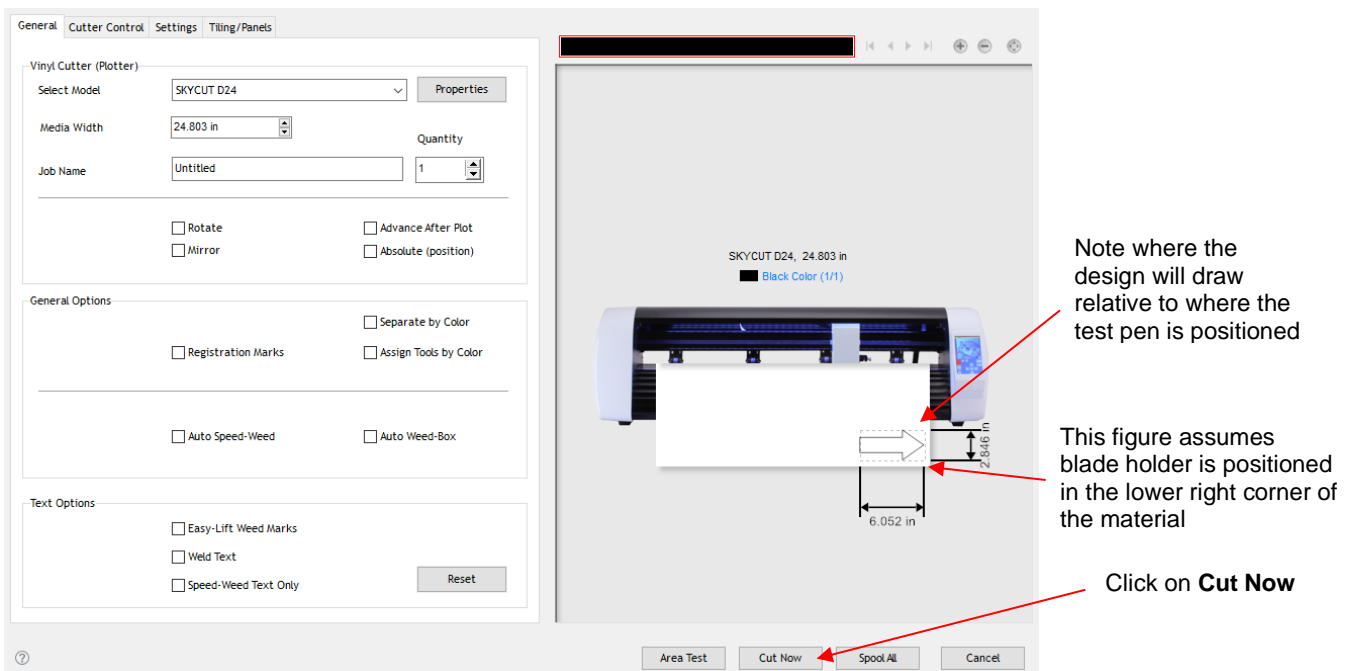

- Insert a USB flash drive into your computer and allow Windows to find it. Note the drive letter assigned by Windows.
- Click on **Cut Now** and a **Save PLT File** window opens because earlier you had changed the connection type to **U_Disk**. Browse to locate the USB flash drive you plan to use and name your PLT file:

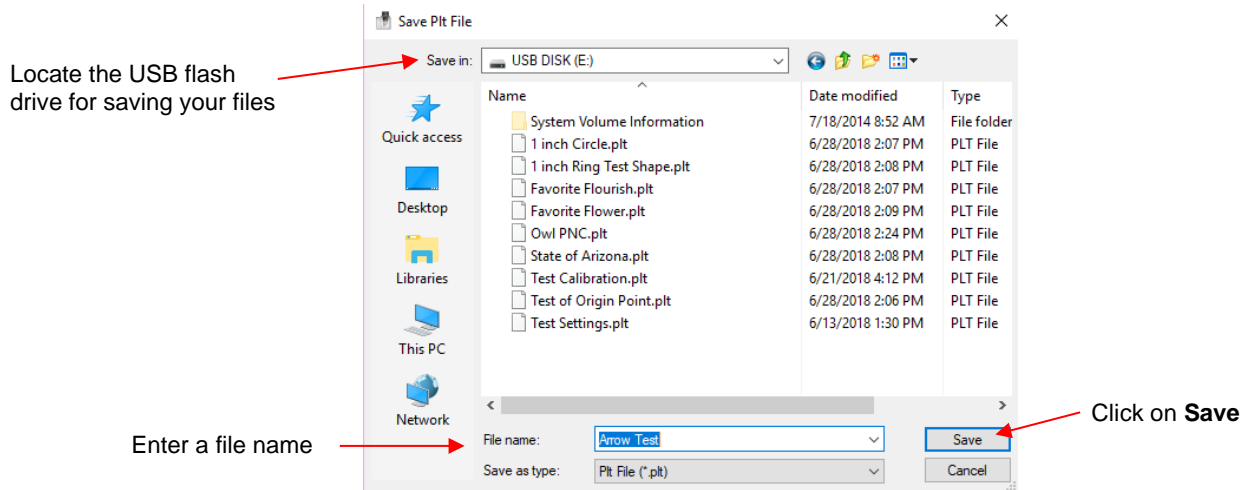

- After saving the file, eject the flash drive and insert it into the right side of the Skycut. On the control panel, select **USB** and then **Open File**:

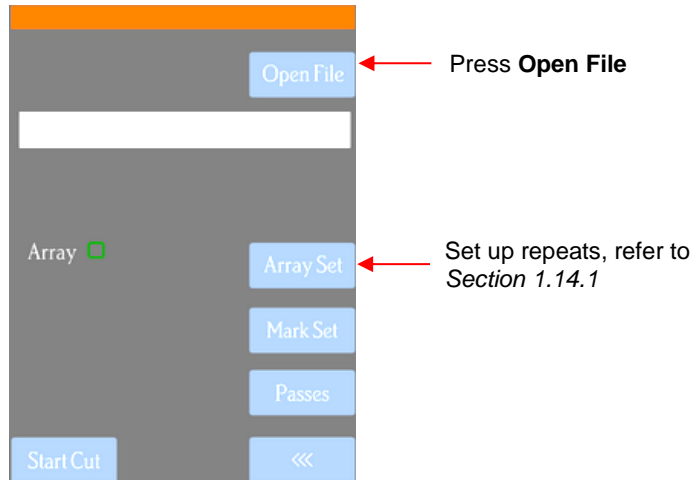

- Double tap on **USB DISK** and a screen will open showing any folders and PLT files on the flash drive. Double tap a folder to open it, as needed. Drag the scroll bar on the right to see more files:

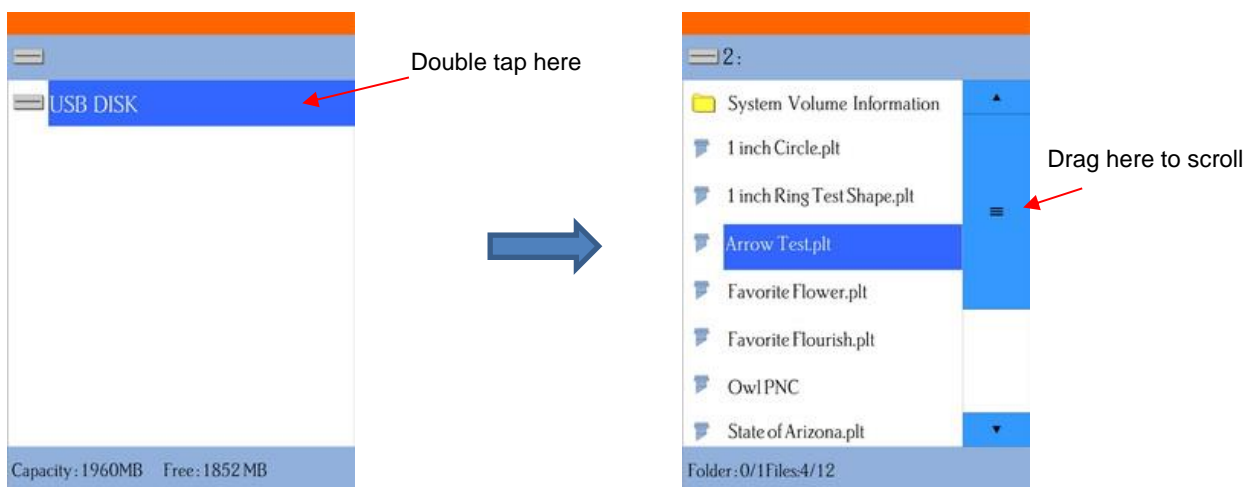

- (2) Once you have located the PLT file you want to cut, double tap the name. You will be taken back to the USB screen and the selected file name will be displayed:

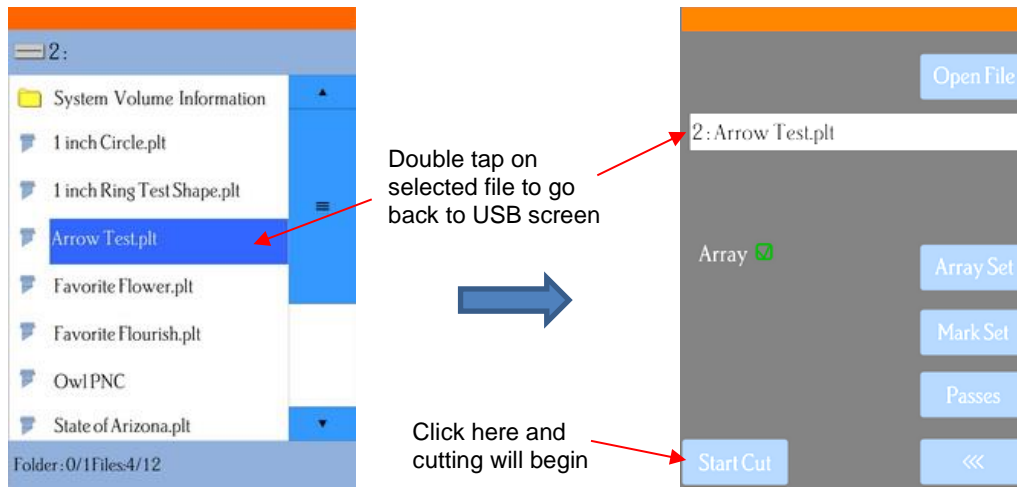

- (3) If you wish to cut repeats of the file, select **Array Set** and a screen will open where you can then select the number of rows and columns of repeats, along with the spacing between the repeats. Refer to *Section 1.14.1*.
- (4) If your project is a print and cut (aka contour cut) application, please refer to *Section 3.08*.
- (5) When you are ready to cut, click on **Start Cut**.

1.13 Test Draw Shapes

- New owners tend to be VERY eager to try out their Skycut. It's important to test your cutter to ensure that data is being sent properly from your computer to the cutter. The following steps will allow you to do some testing with the pen tool. But note that **the following steps are for DRAWING, not cutting**. Before inserting the blade holder into your cutter, please read the following *Sections 1.07.4, 1.07.5, 2.01, 2.02, and 2.03*.
- It is also very important to understand where shapes will cut based on various available options in SignMaster. This is partially addressed in the next section; complete details are covered in *Section 2.02.2*.
- Before setting up a file for testing, if you are new to SignMaster, it is recommended that you watch the following introductory video: [Video](#)
- You have two options when using the test pen:
 - ◇ Insert a sheet of paper directly into the cutter. Make sure the paper is past the ruler so that it doesn't catch when feeding the paper forward:

Observe how pinch wheels are centered with white rectangles

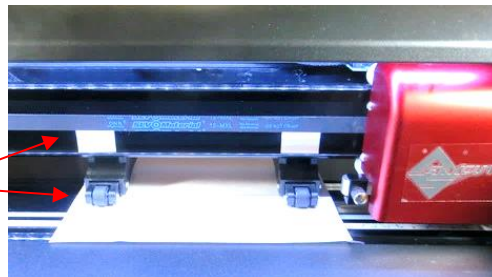

- ◇ Or...Place the paper onto the cutting mat and then insert the cutting mat into the cutter:

Observe how pinch wheels are centered with white rectangles

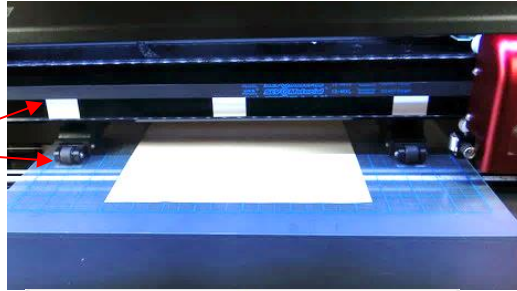

Feed the mat this direction into the Skycut

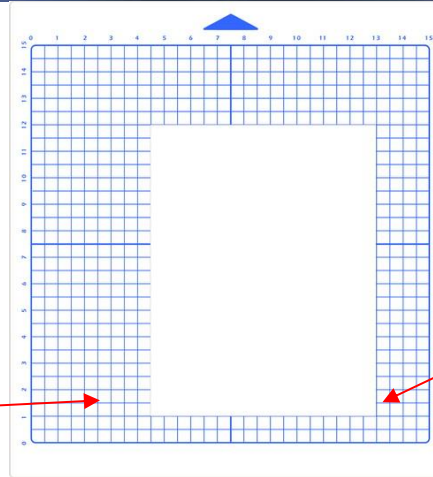

Only the front part of the mat and material will be in the front of the machine.

Align the paper along one of the grid lines on the cutting mat.

- Use any of the horizontal markings at the front of the Skycut (such as the ruler) to align the mat so that it's straight. Lift the pinch lever to drop the pinch wheels onto the cutting mat. Most of the mat and the paper should now be behind the cutter, not in the front.
- Before installing the test pen, make sure the pen will write by scribbling on scrap paper. Note that you will probably need to remove a tiny bit of wax on the end of the pen nib. Then follow these steps:
 - ◇ Loosen the screw on the left-side blade holder seat, which is considered the “default” side.
 - ◇ Insert the blade holder allowing it to freely rest on top of the paper.
 - ◇ Before tightening the front screw, raise the test pen up a little bit (~ 1/8” or several mm). You don't want the pen still touching the paper but you also don't want the pen too high above the paper either.
 - ◇ Tighten the front screw to lock in the test pen. Be careful not to push down on the blade holder seat while tightening.

IMPORTANT! This is NOT the recommended method for loading the blade holder into the cutter. This is presented as a quick way to insert the test pen so that it is in a good position for drawing. The instructions for inserting the blade holder will be covered in *Section 2.01.3*.

- The arrow keys on the Skycut's control panel will always be used to set the origin for cutting:

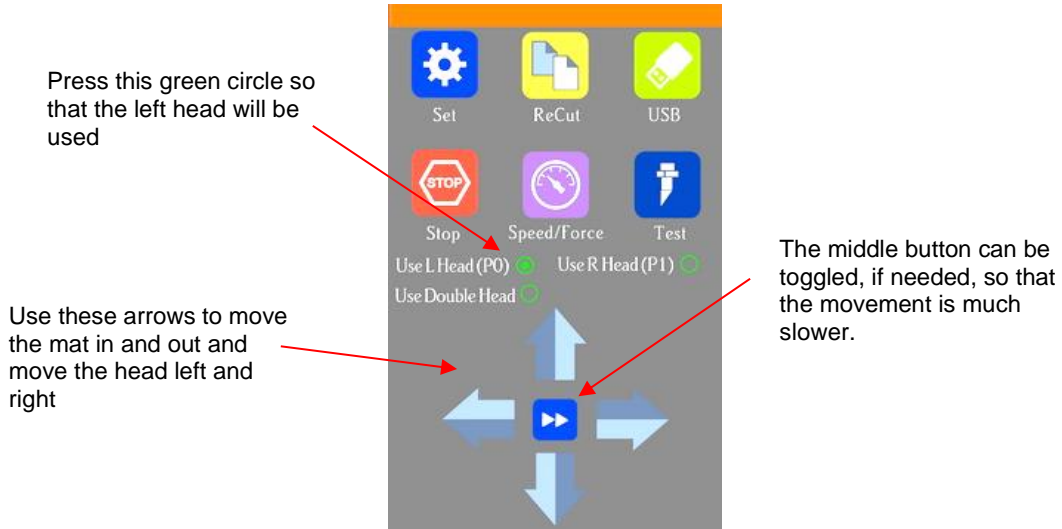

- ◇ Click on the buttons or the arrow keys on your keyboard to move the head left or right and the mat in and out. The goal is to have the tip of the pen close to the lower right corner of the paper:

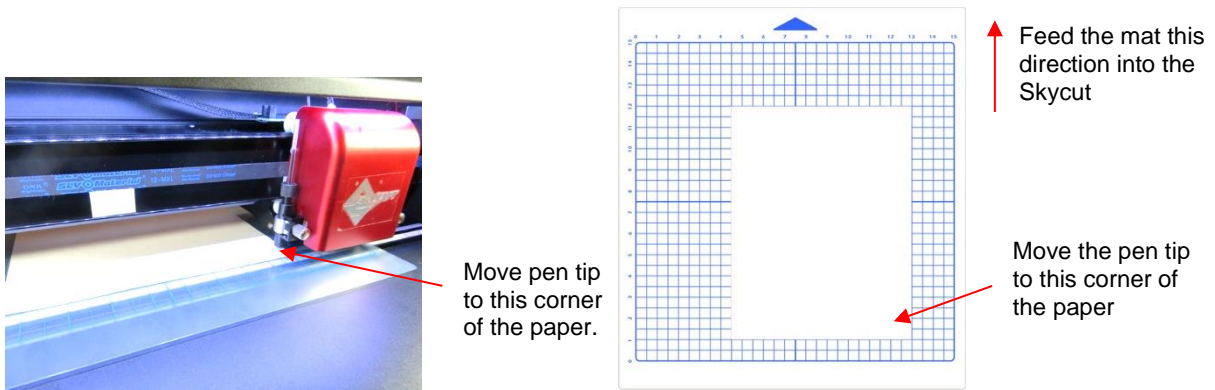

- ◇ Once the pen tip is near the lower right corner, you are ready to proceed with the test.

- The **Force** and **Speed** will also be set using the control panel. Press the **Speed/Force** button  and the following window opens where you can set the Speed and Force to the settings shown. Note that you can either press the + and - buttons or you can slide the orange bar with your finger or stylus:

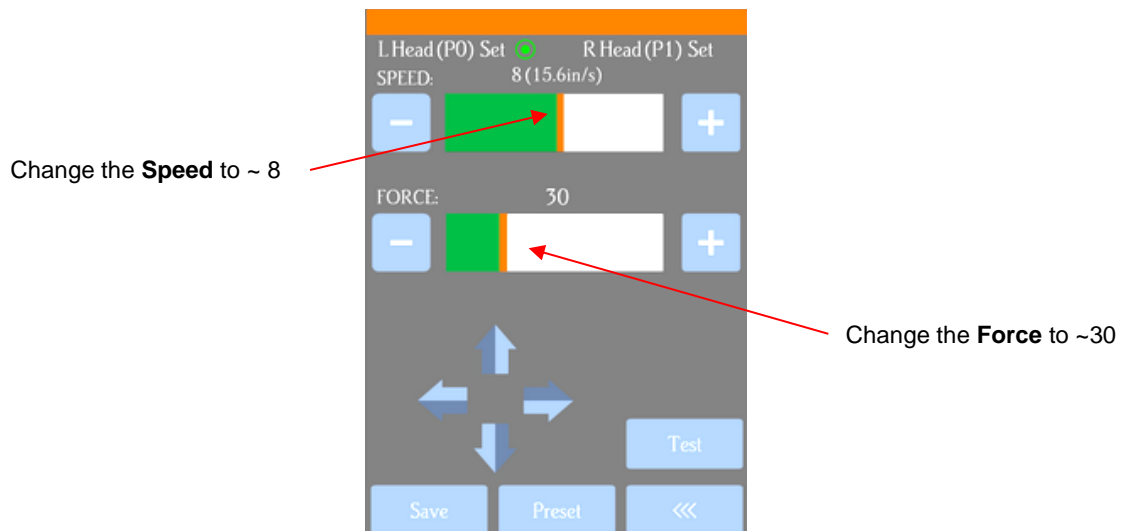

- In SignMaster, on the left side tool panel, press and hold the **General Power Shapes** icon and, from the drop-down menu, select the **Arrow** option:

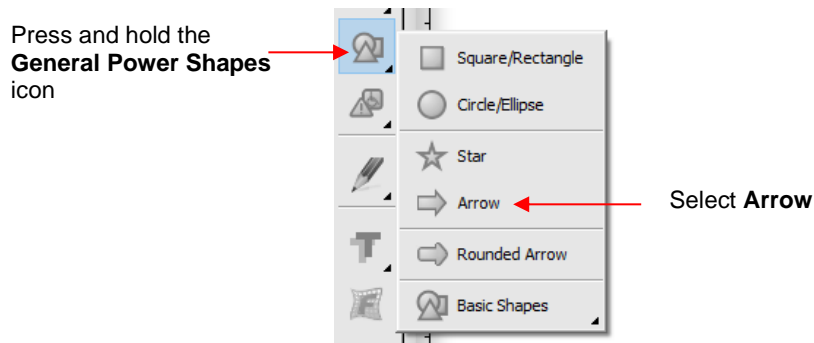

- Press and hold the left mouse button and drag the mouse in the **Drawing Area** to create the arrow shape. In this test, it doesn't matter where you place the arrow on SignMaster's **Drawing Area**, as it will be drawn at the origin you set on the machine.

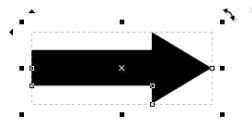

- If you wish to resize the arrow, either drag one of the square handles around the selected arrow or, in the settings above the **Drawing Area**, change the **Width** or **Height**, if desired:



- At this point, if you plan to export this file to a USB flash drive, rather than cut directly to the Skycut from SignMaster, please go to *Section 1.12.4* for instructions.
- After making any changes to the design, click on the **Cut, Plot & Engrave Tools** icon  and select **Send to Cutter**. The following window opens. More about the settings on the left side of the window will be covered in *Section 2.03*. For now, just note where the shape will cut relative to the material:

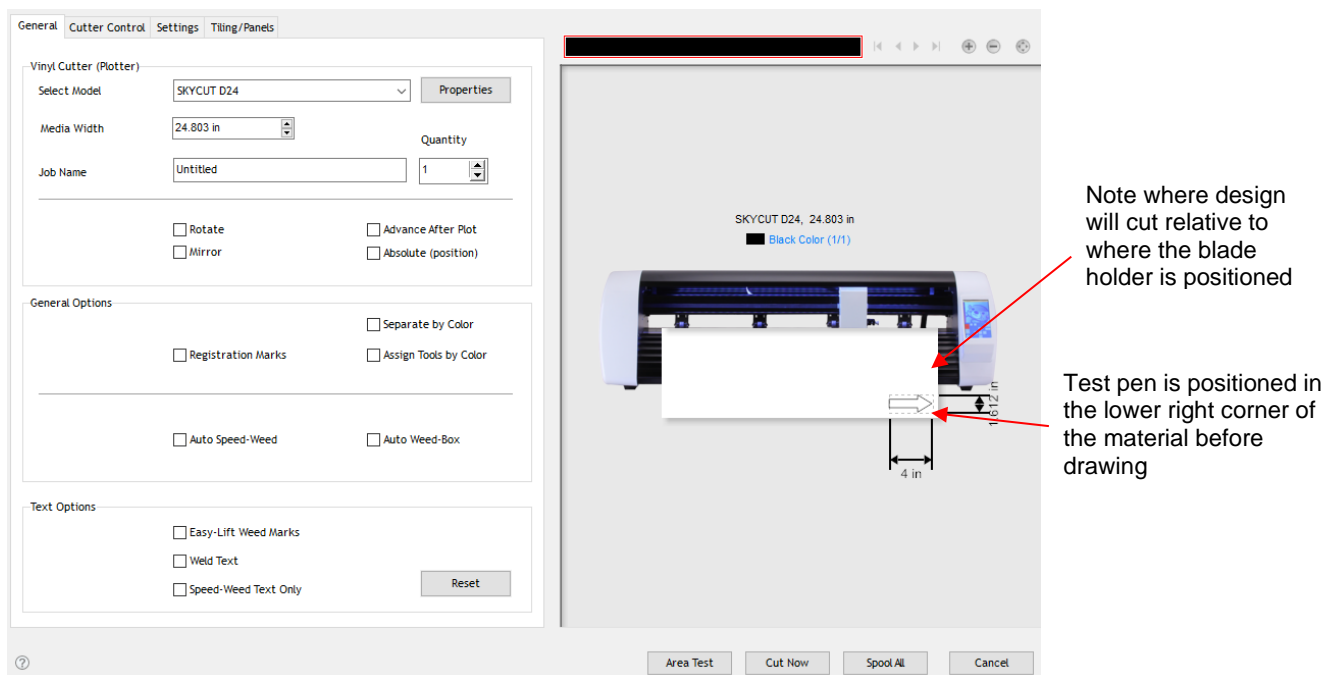

- Before executing the cut/draw process, the **Pen** tool will be selected. Click on the **Cutter Control** tab and the following settings will be displayed:

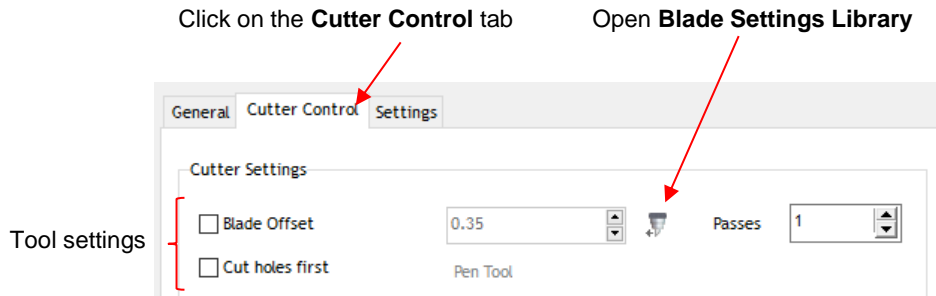

- Click on the small icon  to left of **Passes** and the **Blade Settings Library** opens:

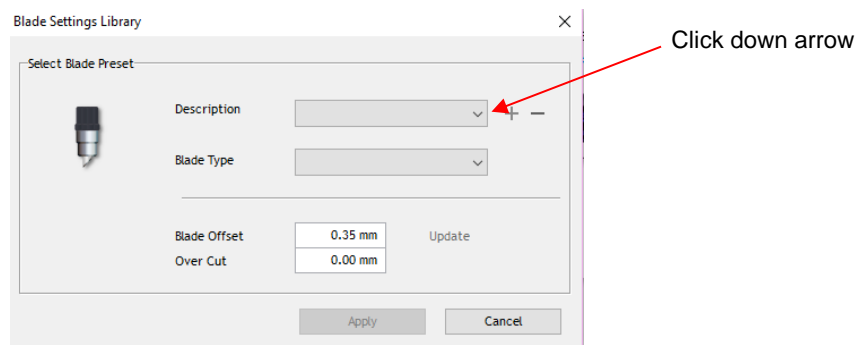

- To switch to the test pen, click the down arrow to the right of **Description** and select **Pen Tool**:

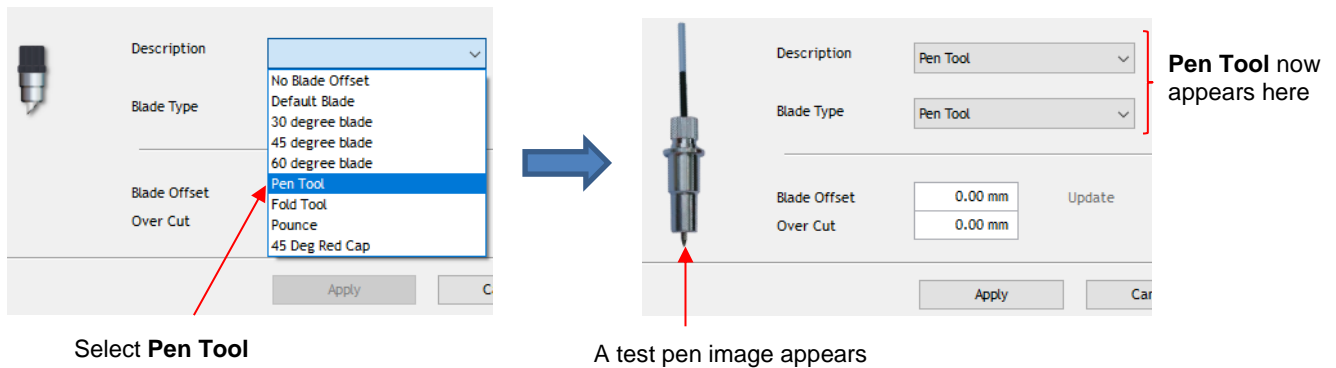

- Click on **Apply** and the **Cutter Settings (Tool settings)** will update showing a 0.00 setting for **Blade Offset** (more about this setting is covered in *Section 2.03.3*):

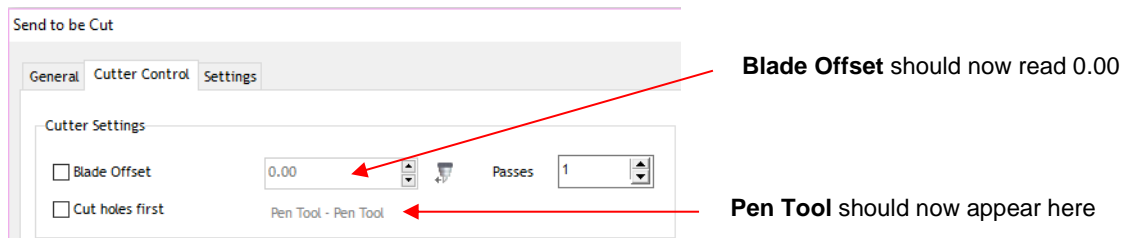

- Click on **Cut Now** and a confirmation window opens. Answer **Yes** to proceed, **No** to cancel:

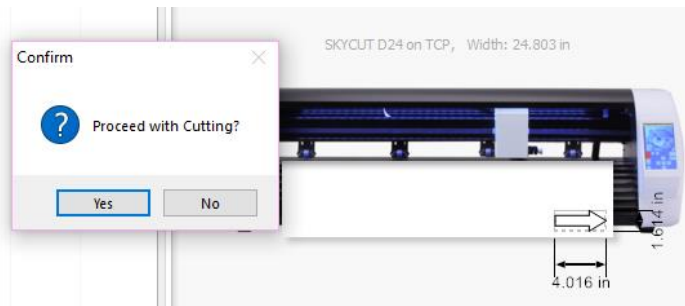

- After selecting **Yes**, the Skycut will draw the arrow on your paper:

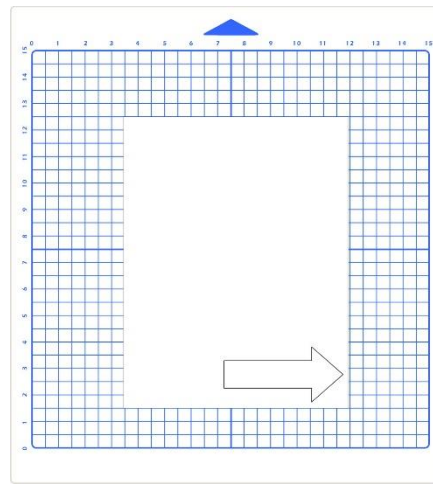

↑
Feed the mat this direction into the Skycut

The arrow is drawn at the origin and points to the right.

- To draw again, return to the cut window and choose a different origin. Practice moving the origin to different locations. If you want to have the arrow draw in a **Landscape** orientation, then mark the **Rotate** option. You will see the arrow rotate in the **Preview**:

Check Rotate

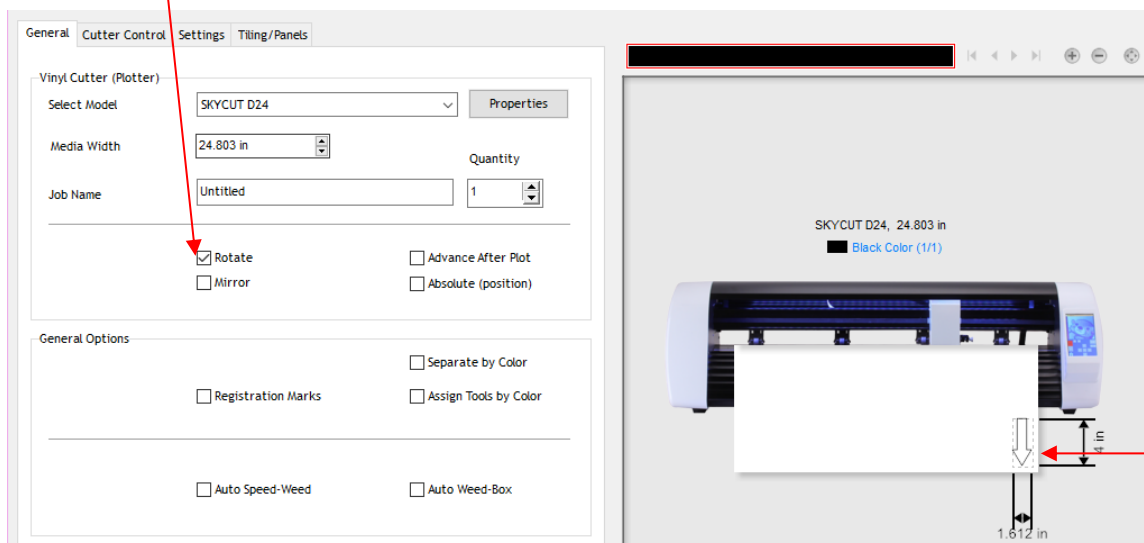

Note arrow is now rotated

- Cutting with this setting results in the arrow pointing downwards as shown in the prior preview window:

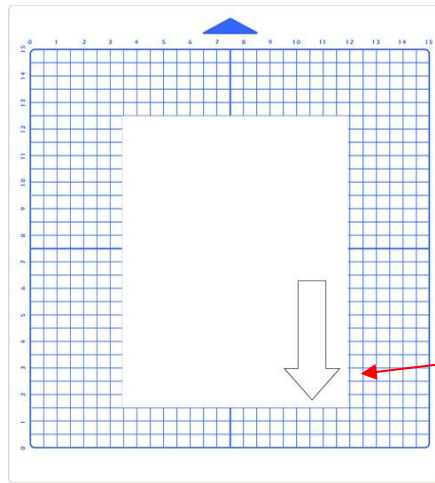

Feed the mat this direction into the Skycut

The arrow is drawn at the origin and points down

- If you want the arrow to draw where you have it located on the **Drawing Area** in SignMaster's main screen, versus at the origin, then you need to mark the option called **Absolute (position)** in the same **Send to be Cut** window:

Location of arrow in Drawing Area

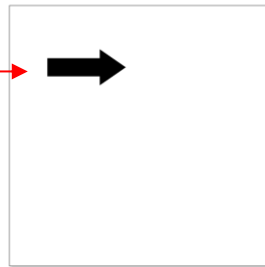

Check **Absolute (position)**

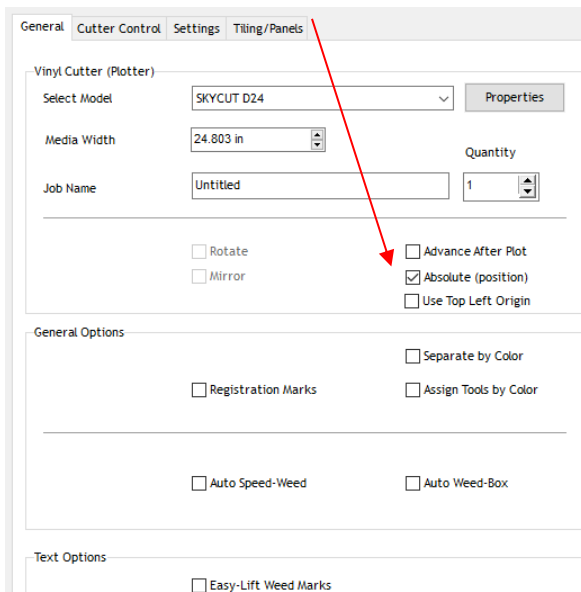

Arrow will now draw in this location

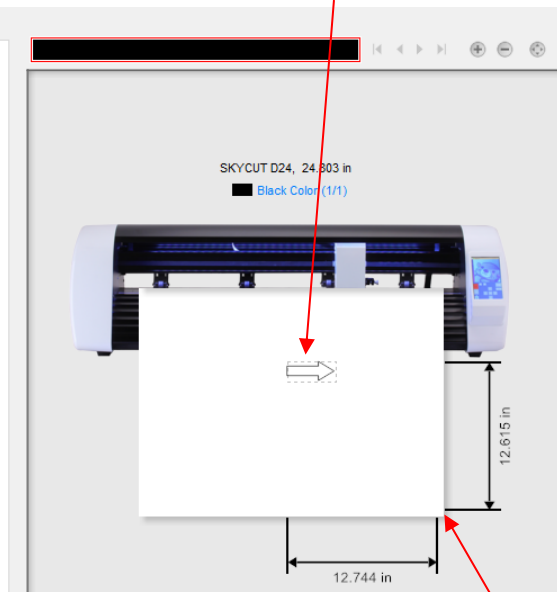

Test pen is still positioned in lower right corner of material before drawing

- Set the origin in the lower right corner of the mat's grid and then place the paper in the correct location on the mat to correspond to where the shape is positioned in SignMaster. Refer to *Section 2.02.2* for more details on controlling where images will cut.

IMPORTANT: Please read *Section 2.01* before cutting!

1.14 Default Settings To Consider

- The Skycut's control panel offers a number of default settings. Some of these may not be important at this point in the learning process. So, you may want to skip this section for now but remember that it's here and could provide you some options to improve your experience with the Skycut.
- Each of the following sections will refer to one of the settings in the **Set** screen.

1.14.1 Advanced Settings

- The optional settings in the **Advanced Settings** screen are:

Set up rows & columns of repeats →

Separate **Cut Speed** from **Up Speed** →

Option to change directions on up/down keys →

Sizing Calibration Refer to *Section 2.08* →

Display (X,Y) location of cutting head ←

Turn on if you want cutting head to move to the far right when cutter is powered on ←

Option to change back to single head only ←

- **Array:** Tap the **Array** button to open the **Array** screen:

Tap here to turn on **Array** ←

Repeats for a print and cut application Refer to *Section 3.08* ←

Number of repeats: left to right ←

Number of repeats: up & down ←

Spacing between left-to-right repeats ←

Spacing between up-&-down repeats ←

◇ In the above screenshot, the shape sent to the Skycut would cut 3 across and 7 up & down, for a total of 21 shapes. The spacing between each shape would be 0.20 inches (Note: to use mm instead of inches, switch the **Units** setting. Refer to *Section 1.14.2*).

- **Show Point:** When toggled on, the **Main Screen** displays movement and location output based on the position of the cutting head:

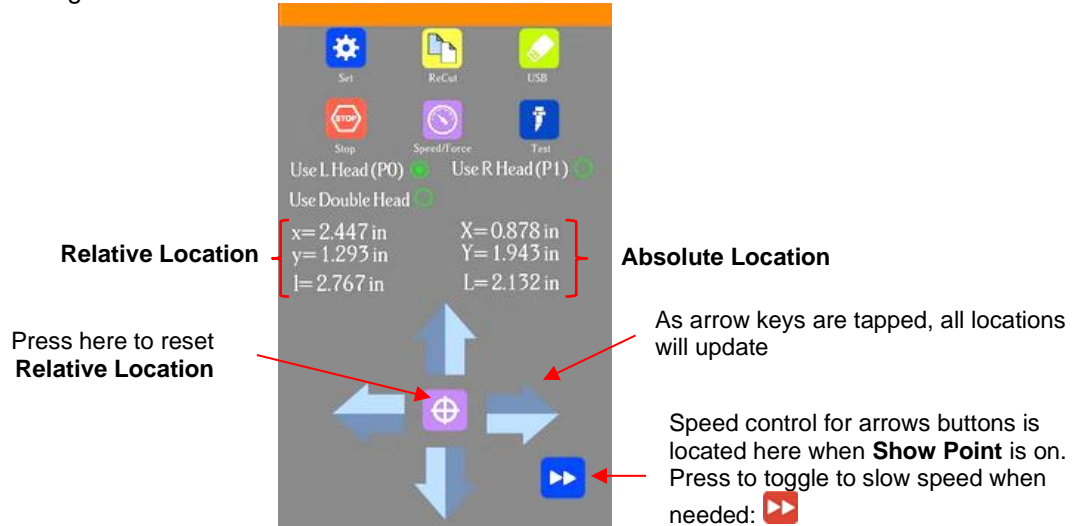

- ◇ **Absolute Location** displays the current location relative to a “power-on” location of (0,0):
 - **X** is the left-to-right location
 - **Y** is the up-&-down location
 - **L** is the straight-line distance from (0,0)
- ◇ **Relative location** displays the change in location currently being made as you press the arrow keys:
 - **x** is the current left-to-right distance moved from **X**
 - **y** is the current up-&-down distance moved from **Y**
 - **l** is the straight-line distance from the (**X**,**Y**) location
- **Up Speed** is how fast the blade travels while in the “up” position, such as when it is moving from the origin to the location of the first shape to cut or when moving from one cut shape to begin cutting another. When turned off, **Up Speed** will match the **SPEED** set for cutting. Turning on this setting will change the **Speed/Force** screen to display both speeds, allowing them to have different settings:

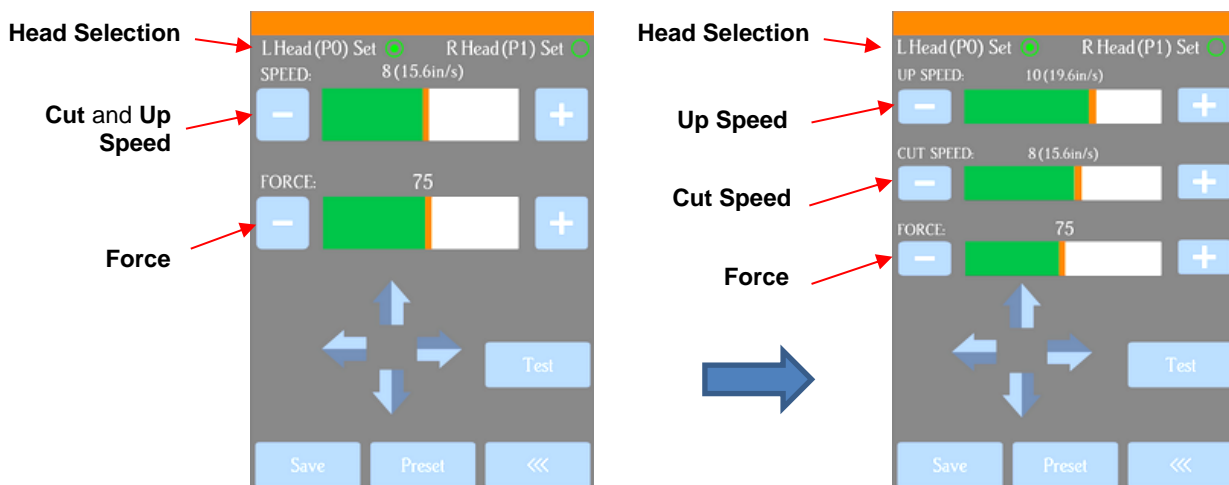

- **To right power on:** With this setting turned on, the cutting head will move to the far right whenever the Skycut is powered on.

- **Y Key Mode:** This setting controls the movement of the material or cutting mat when using the up and down arrows in the **Main Screen**:

Pressing an **UP** arrow will move the material forward

Pressing a **DOWN** arrow will move material towards the back of the cutter

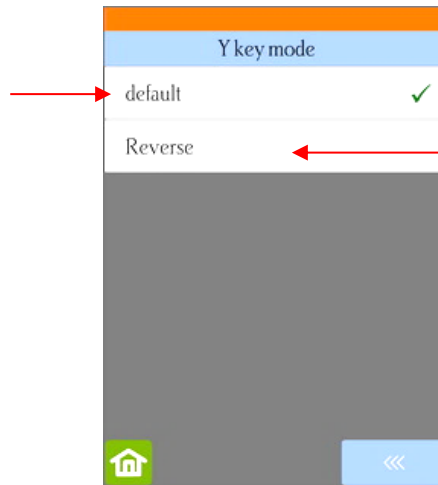

Pressing an **UP** arrow will move the material towards the back of the cutter

Pressing a **DOWN** arrow will move material forward

- **System Mode** is used to select whether or not the dual head options (D model only) are available on the main screen:

Normal cutting/drawing with just the blade holder or test pen

Option to use both heads

When enabled, camera will only take one photo at each registration mark

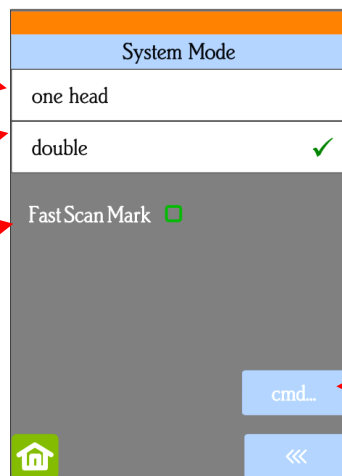

Activate command: refer to *Appendix C*

- **Scale** is used is used to input the sizing calibration. Refer to *Section 2.08*.

1.14.2 General Settings

- The optional settings in the **General Settings** screen are:

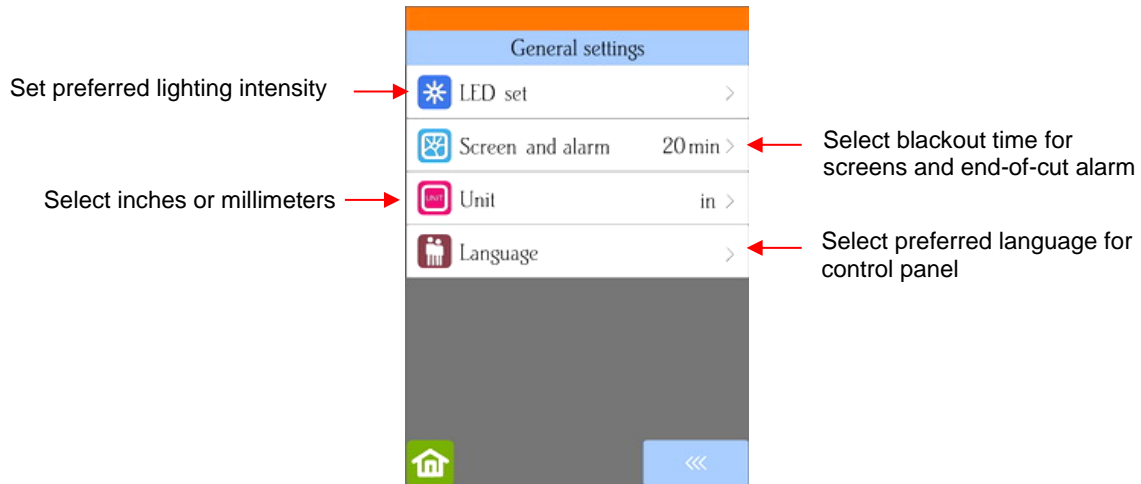

- **LED set** allows you to change the brightness of the light inside the Skycut or even turn it off:

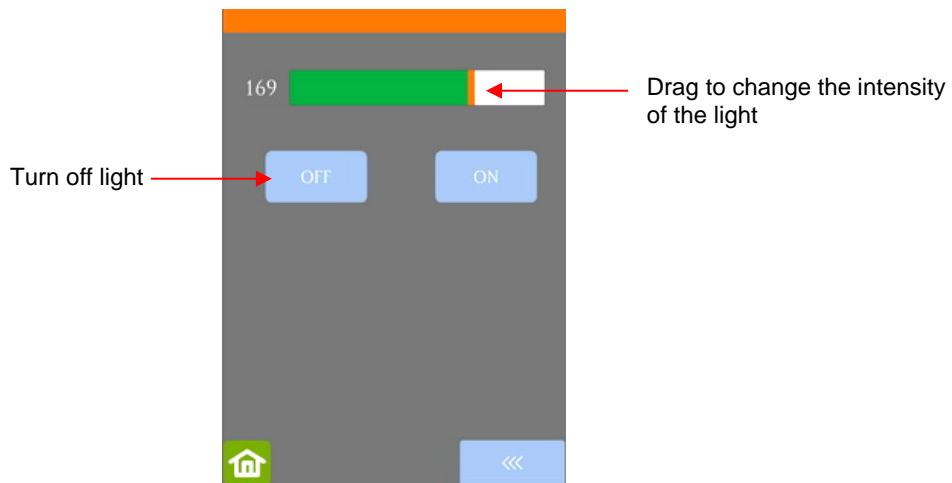

- **Screen and alarm** has two settings:

- ◇ **Screensaver time:** Set a black-out time, in minutes, for the control panel
- ◇ **Alarm after finish working:** When a job is complete, have an alarm sound (five beeps)

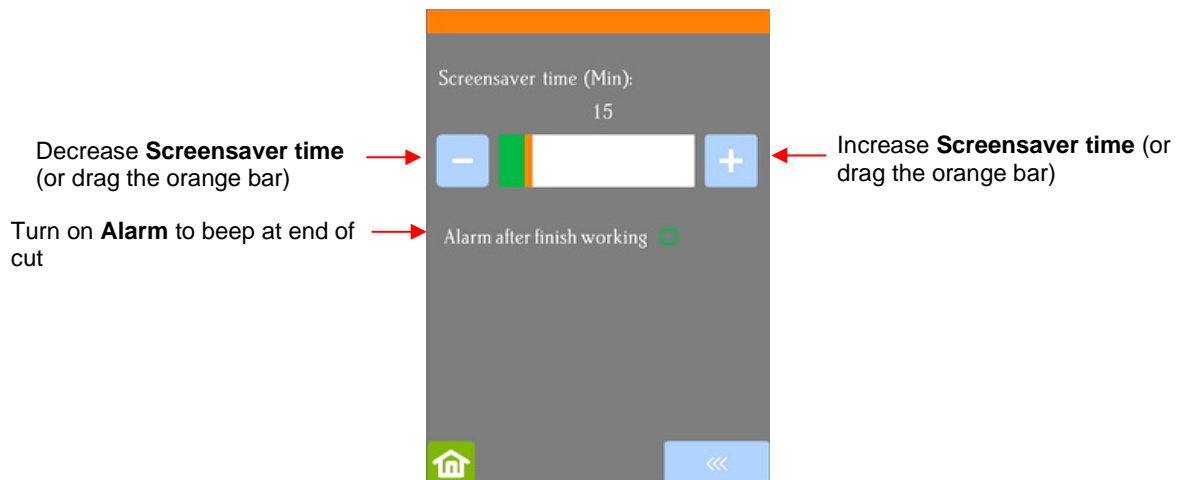

- **Unit** allows you to choose either inches or mm for settings such as **Show Point** and the **Spacing** setting under **Array**.



- **Language** allows you to choose from eight languages to be used throughout the control panel display screens:



1.14.3 Sys Information

- The **Sys Information** screen displays information about the Skycut and only has three setting changes available:



- ◇ This initial screen displays current version numbers.
- ◇ If you ever need to reset your Skycut, press and hold **Default All** until it turns red. Then wait for the button to update to **Success!**
- ◇ If you ever need to change which software is in use with your Skycut, press and hold **SOFT** for two seconds and release. The following screen will open:

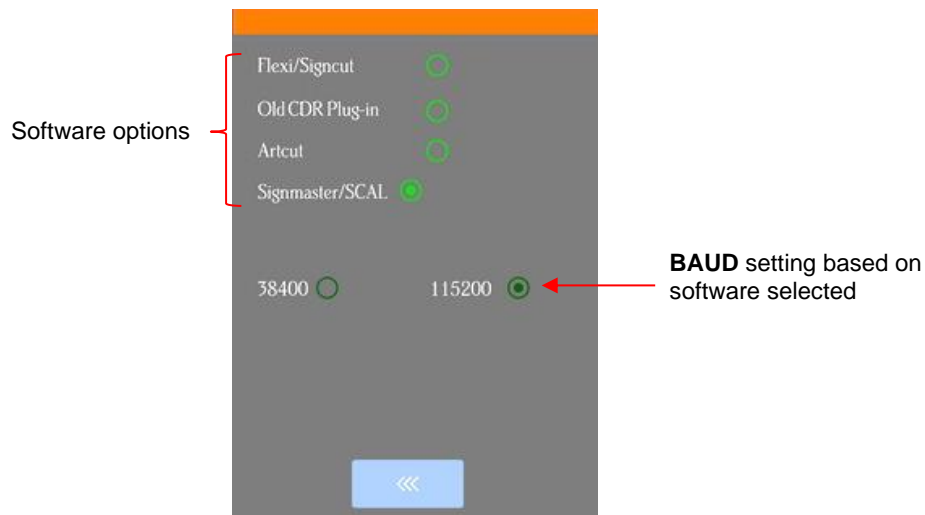

- ◇ To use a different software program to cut to the Skycut, press inside the appropriate circle. The **Baud Rate** indicator will automatically change if needed.

1.15 Maintenance

Skycut machines do not require any kind of lubrication or routine checks. However, here are a few things to keep in mind for successful operation of your cutter:

- Keep the pinch wheels clean. Depending on the adhesive being used on the cutting mat, it's possible for the pinch wheels to become sticky and pick up small pieces of cardstock or other material being cut. This can lead, in some cases, to the mat skewing or ruining materials during subsequent cuts. To clean the pinch wheels, use a lint-free cloth and an adhesive remover such as isopropyl alcohol or Un-Du to clean the pinch wheels thoroughly.
- Keep the grit shafts clean. Equally important as the pinch wheels, the grit shafts beneath the cutting mat should also be free of adhesive and tiny bits of material. They can be cleaned the same way as the pinch wheels. Note: Do not pour cleaner onto a grit shaft. Instead, dab some adhesive remover onto a lint-free cloth and then use the damp cloth to clean the shafts. You can also use tweezers to remove any material or adhesive that is stuck to a shaft.
- Keep the cutting mat clean and sticky. As mentioned in the *Section 1.08.2*, the cutting mat can be washed with soap and water to remove small invisible pieces of material which are reducing the tackiness of the cutting mat. After drying, you can add more repositionable adhesive, if needed.
- Check your blade holder, as needed. If suddenly you cannot get a clean cut, check the blade holder for any tiny slivers of material that may have been caught up by the blade and fed up inside the blade holder.
- If you cut vinyl or other backed materials regularly, you may need to replace the cutting strip at some point. You will be able to tell based on seeing deep cuts in the strip and an inconsistency in the cutting. Contact your dealer for information on obtaining a replacement.

1.16 Other Useful Tools and Supplies

- The following list has items you may or may not need while enjoying your Skycut. These are suggestions based on twelve years of collecting information from other cutter owners:
 - ◇ Brayer or Rolling Pin: (1) to apply lint from a towel onto an overly sticky mat (2) to press materials evenly onto a mat for cutting
 - ◇ Post-It Notes: (1) for setting blade/tool tip height above a material (2) for draw and cut applications

- ◇ Old Fluffy Bath Towel: (1) to dry a washed mat (2) to apply an invisible layer of lint onto an overly-sticky mat
- ◇ Dishwashing Soap: (1) to remove visible and invisible fibers from the mat, thus renewing the adhesive (2) to clean the mat well before adding more adhesive
- ◇ Soft Brush: (1) to gently remove waste scraps during the washing of a mat. Refer to *Section 1.08.2*.
- ◇ Artist Palette Knife: (1) to gently remove cut shapes from a mat (2) to scrape off small waste pieces from a mat
- ◇ Blue Painter's Tape: (1) to tape around the edges of thicker materials that might slip during cutting
- ◇ Repositionable Adhesives: (1) to add more adhesive to a cutting mat (most any brand or type can be used, provided it is repositionable). Refer to *Section 1.08.2* for suggestions and instructions.
- ◇ Adhesive Removers: (1) to completely strip a cutting mat of adhesive (2) to disarm adhesive long enough to remove large scraps of material that will not peel off
- ◇ Lint-free Cloth: (1) for dusting off your cutter and cleaning pinch wheels and grit shafts
- ◇ Awl or Paper Piercer (or other sharp pointed tool): (1) to pick or lift out a test cut to verify results
- ◇ Stabilizers: A stabilizer is an adhesive material that is applied to the bottom of the material you are cutting so that cleaner cuts can be achieved. The stabilizer works in one or more of the following ways – (1) provides firmer contact with the cutting mat (2) provides a final layer that does not need to be cut if the stabilizer will be removed after cutting (3) prevent some slightly-elastic materials from being stretched by the blade. Recommended stabilizers include freezer paper, Thermo-web Heat n' Bond, and Steam-a-Seam 2.
- ◇ Double-sided Tape: (1) For securing metal tags or charms to the cutting mat for engraving
- ◇ Non-slip Shelf Liner: (1) To place under cardstock and other material when embossing

2. Cutting

2.00 Quick Reference for this Chapter

- How to *properly* mount the blade holder: *Section 2.01.3*
- How to control which shapes get cut: *Section 2.02.1*
- How to control where shapes get cut: *Section 2.02.2*
- Understanding **Blade Offset** and **Overcut**: *Section 2.03.3* and *Section 2.03.4*
- How to set a very precise origin: *Section 2.05.1*
- How to add weeding lines to a cut: *Section 2.06.3*
- Checklist before cutting: *Section 2.07*
- How to get shapes to cut to precise dimensions: *Section 2.08*
- How to know which settings to adjust to solve cutting issues: *Section 2.09*

The Most Common New Owner Mistakes:

- Too much blade is exposed on the blade holder (material is lifting up and/or tearing) - refer back to *Section 1.07.5*
- The blade holder or test pen haven't been properly mounted - refer to *Section 2.01.3*
- The pinch wheels are not properly positioned (material or mat is sliding around or bunching up during the cut) – refer back to *Section 1.09*
- Failing to do a test cut (recommended cut settings are not working) – refer to *Section 2.01.5* and *2.09*
- Not practicing enough with the test pen and paper (shapes are not cutting in the correct locations) – refer to *Section 2.02.2*

2.01 What You Need to Understand About Cutting

IMPORTANT: Please read all of 2.01!!!

2.01.1 You Have To Make Mistakes

- The key to becoming successful at cutting is to do a lot of it. Those who shy away from using their Skycut will never get to the stage of mastering it. It's very normal for new owners to be intimidated by their cutter, so remember the following key things:
 - ◇ You won't break your new Skycut by cutting paper, vinyl, cardstock, and other easy-to-cut materials. The worst thing that might *possibly* happen is that you'll break a blade. That's it! And the likelihood of even that happening is low.
 - ◇ You need to start cutting so that you'll begin making mistakes! It's in making these mistakes that you start to learn. You realize that these mistakes didn't result in a broken cutter. Plus, you'll stop making the same mistakes as you remember more of the things you need to check before every cut.
 - ◇ As you make fewer mistakes you begin to build confidence and you begin to have more cutting success. From there, you begin to experiment more and produce more. Thus, your best course of action is to just start cutting... a lot! But first, read the rest of this chapter.

2.01.2 Record Your Successes

- As you have successful cuts, take note of the settings you just used, such as **Force**, **Speed**, blade type, number of passes, brand of material, etc. There is a blank form in *Section 2.10* that you can print and use to record your results. There are also suggested settings for common materials at the end of this chapter. Use these as starting guides but remember that your results may vary based on the many factors which can affect cutting.

2.01.3 Installing the Blade Holder, Test Pen, or Accessory Tools

- The gold blade holder has a rim around the outside that will, when cutting most materials, rest on the silver part of the blade holder seat. When inserting the blade holder, loosen the front screw and then grasp the top and the bottom of the black piece and move back a bit while inserting the blade holder. The blade holder should then drop down so that the rim is below the black top piece of the blade holder seat:

Rim of blade holder is resting on the silver part of the blade holder seat

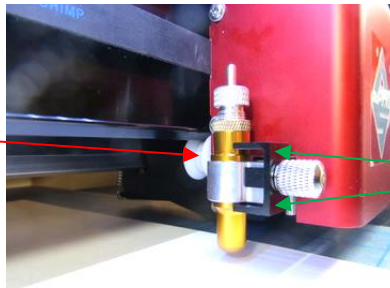

With the front screw loose, the black piece can be moved back just a little bit to allow the blade holder to drop down.

- The **Blade Height** is the distance from the tip of the blade to the top of the material you are about to cut. Thus, in the photo above, you can see that there are several millimeters of **Blade Height** which is important for two reasons:
 - ◇ You do not want the blade dragging across the material when the blade holder is moving from the origin to the first shape to cut (or between shapes).
 - ◇ More force is applied when there is a drop distance for the blade holder to start cutting. This is also referred to as “punch room” and provides more consistent cutting across the width of the machine.
- When cutting a very thick material, such as 2 mm craft foam, it is recommended that the rim on the blade holder be resting on top of the black piece:

IMPORTANT: Only install this way when cutting very thick materials!

Rim of blade holder is resting on the black part of the blade holder seat

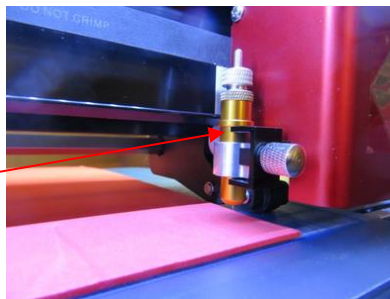

- When using the test pen or an accessory tool without a rim, you'll need to insert the tool using a spacer on top of the material. A stack of 35 Post-It notes or 35 sheets of regular copy paper work well.
 - ◇ The recommended method for loading the test pen or another accessory:
 - Place the spacer on top of the material, with the material loaded into the Skycut.
 - Loosen the screw on the blade holder seat and insert the tool so that the tip of the tool is touching the top of the spacer:

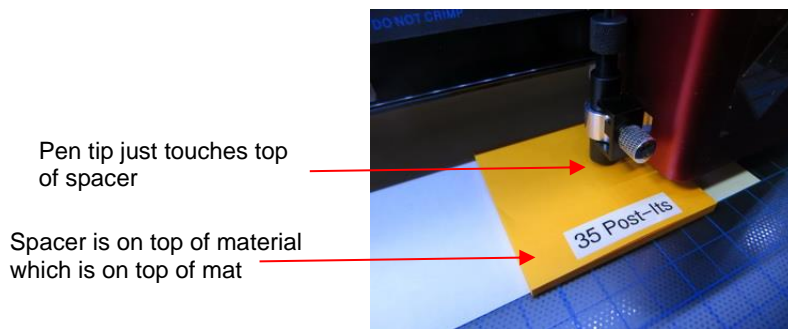

- Now tighten the front screw carefully making sure you are NOT pushing down on the blade holder seat. Once tight, remove the spacer. You should feel the tool gently scratching the top of the spacer.
- This distance will provide the tool some “punch room” to give extra force and more consistent results.

2.01.4 Adjust the Speed, Force, and Number of Passes Based on the Material and Shapes

- Using correct cut settings is equally important as the type of blade, blade length, and blade height. Refer to *Section 2.03* for details about each setting.

2.01.5 Perform Test Cuts!

- You have two options:
 - (1) Perform the built-in test cut on the Skycut itself using the **Test** option on the **Main Screen** or from within the **Speed/Force Screen**.
 - (2) Select any basic shape and size it to be around 0.3” – 0.5” (~ 8 mm – 13 mm):
 - I personally like using a design with an internal shape, such as a ring. You can then easily see if the blade is cutting into the mat (or into the backing sheet on rolled materials) when you lift out the cut shape and observe where the internal shape cut. To locate a ring, click on the **General Power** **Shapes** icon  on the left side **Tool Panel** and go to **Basic Shapes>Basic**.
 - When cutting intricate shapes, use a small letter or a shape with lots of sharp turns for testing. For a rhinestone project, use a small portion of your rhinestone pattern as a test.
- There is a flow chart in *Section 2.09* which will help you determine which settings to change when test cutting a material.

2.01.6 Keep the Cutting Mat Clean and Sticky

- Press your materials evenly to the mat. Consider using a brayer both before AND after cutting. Repressing the material after cutting can greatly aid in weeding the cut shapes from the waste.
- When necessary, tape thicker materials to the mat to keep them from slipping during the cut.
- If you cut a range of materials, you might need more than one mat so that you can use stickier mats for certain materials.
- Refer back to *Section 1.08* for information on cleaning the cutting mat and adding more adhesive,

2.01.7 Don't Get Frustrated, Get Help!

- Besides having your own Skycut dealer as your first line of contact, there are other resources where you can ask questions and get answers. Utilize the resources listed in *Section 1.01*.

2.02 Choices Before Cutting

- There are a number of factors under your control for cutting:
 - ◇ What shapes to send to the cutter: *Section 2.02.1*
 - ◇ Where the shapes will be cut from the material: *Section 2.02.2*
 - ◇ What tool(s) will be used for cutting (or drawing, scoring, engraving, etc.): *Section 2.02.3*
 - ◇ What settings will be used: *Section 2.02.4*

2.02.1 Controlling Which Shapes Will Cut

- There are three ways to control whether a shape will be cut or ignored. In explaining these options, the following shapes have been added to the **Drawing Area**. Note that this file (called *Controlling What Cuts*) is shared in a zip file [available here](#).

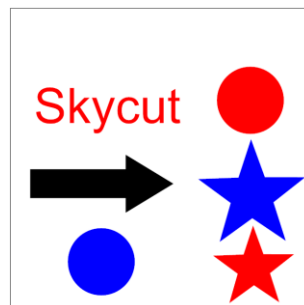

- ◇ **Option 1:** If no shapes are pre-selected, then all shapes will be sent to cut. However, if you pre-select, for example, only the “Skycut” and the arrow, then only those shapes will appear in the **Send to be Cut Preview**:

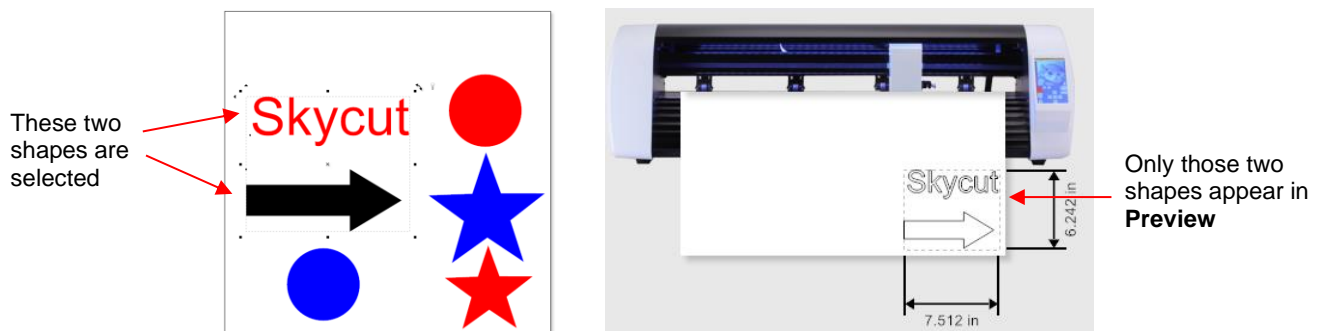

- A more common practice is to select all objects of one color and only have those shapes sent to cut. To do this, go to **Edit>Select by>Color** (or use the shortcut key “S”) and the following window will open where you can, for example, mark **Red** to be selected. Then the **Preview** will only have “Skycut”, the red circle, and the red star present:

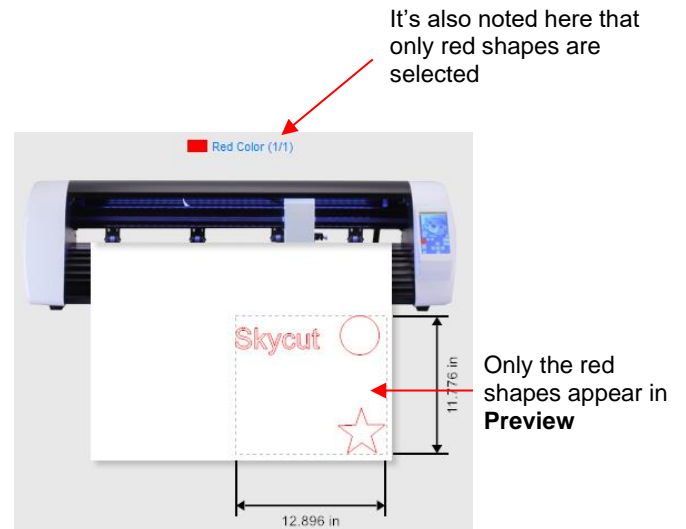
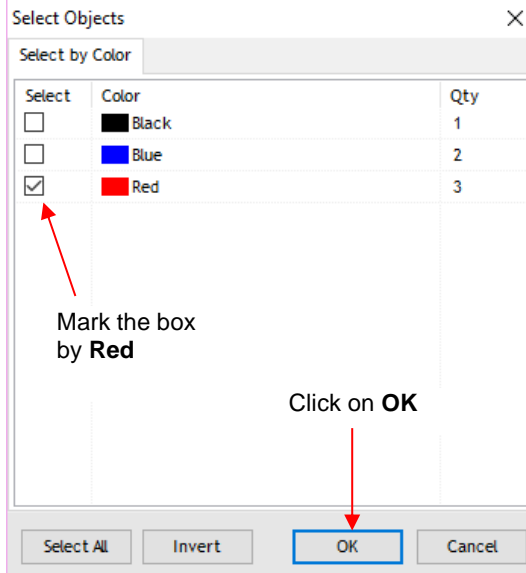

- Along the same lines, you can select all objects of type and only have those shapes sent to cut. To do this, go to **Edit>Select by>Object Type** (or use the shortcut key "O") and the following window will open where you can, for example, mark **Circle** and **Star**. Then the **Preview** will only have circles and the stars present:

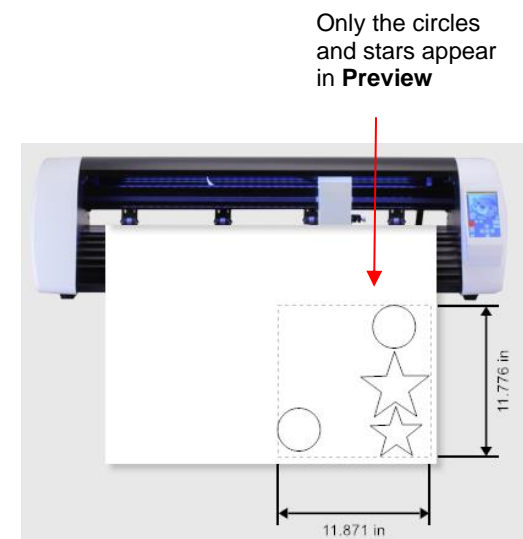
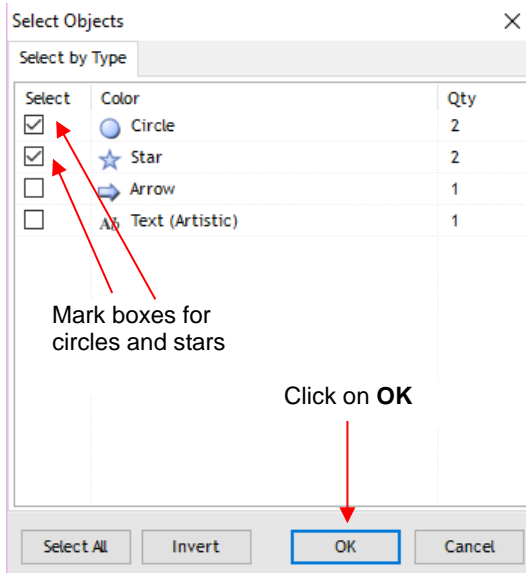

- Note that the icon at the top of the screen:  will open a menu where you can then access the same **Select by Color** or **Select by Type** options:

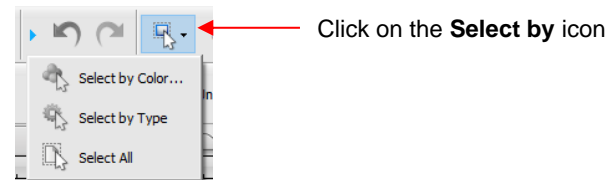

- ◇ Option 2: Mark shapes not to be cut on the **Objects** tab of the **Page Thumbnail Viewer**:
 - To access the **Objects** tab, click on the small icon to the left of the palette:

Click this blue arrow

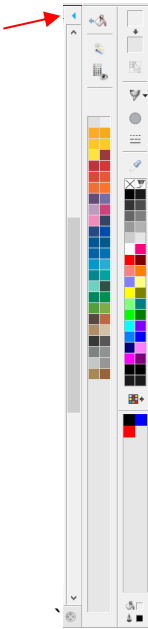

All of the shapes appear in a list

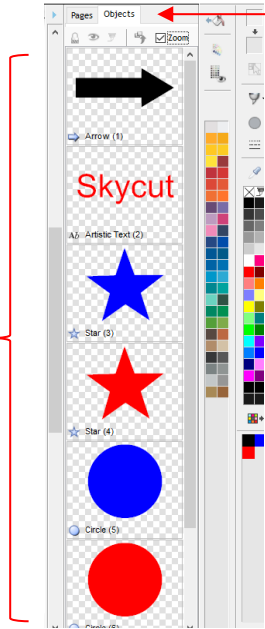

Click the **Objects** tab

- Select a shape, such as the arrow. On the **Object** tab, it can then be set not to cut:

Click this icon to turn off cutting

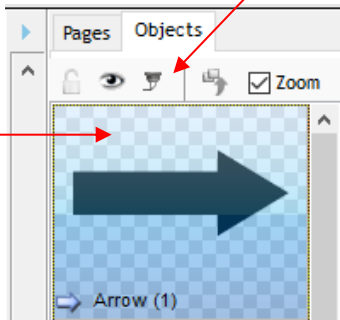

Arrow will not cut

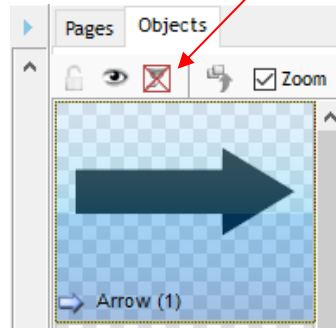

Arrow is no longer in **Preview**

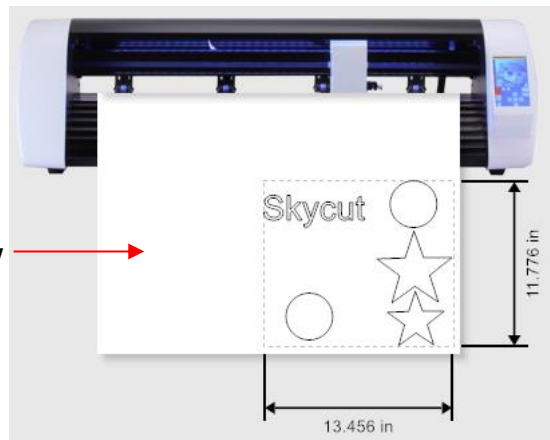

- ◇ Option 3: Cutting can be controlled by color from within the **Send to be Cut** window. Click on the **Separate by Color** option and a drop-down menu will appear:

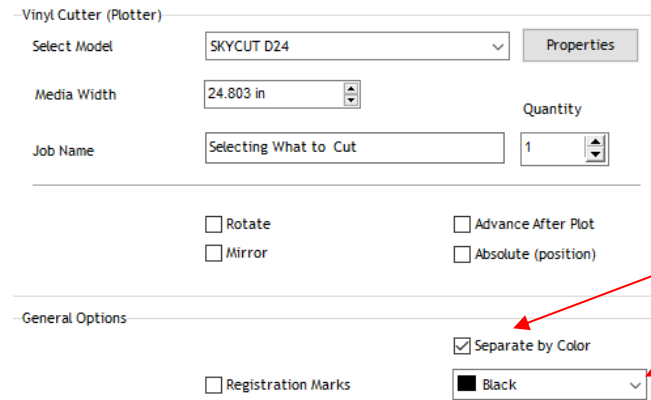

Mark the **Separate by Color** option

Drop-down menu of colors used in the project

- In the **Preview** window, shapes with the current color from the menu appear. Also, the color is selected at the top:

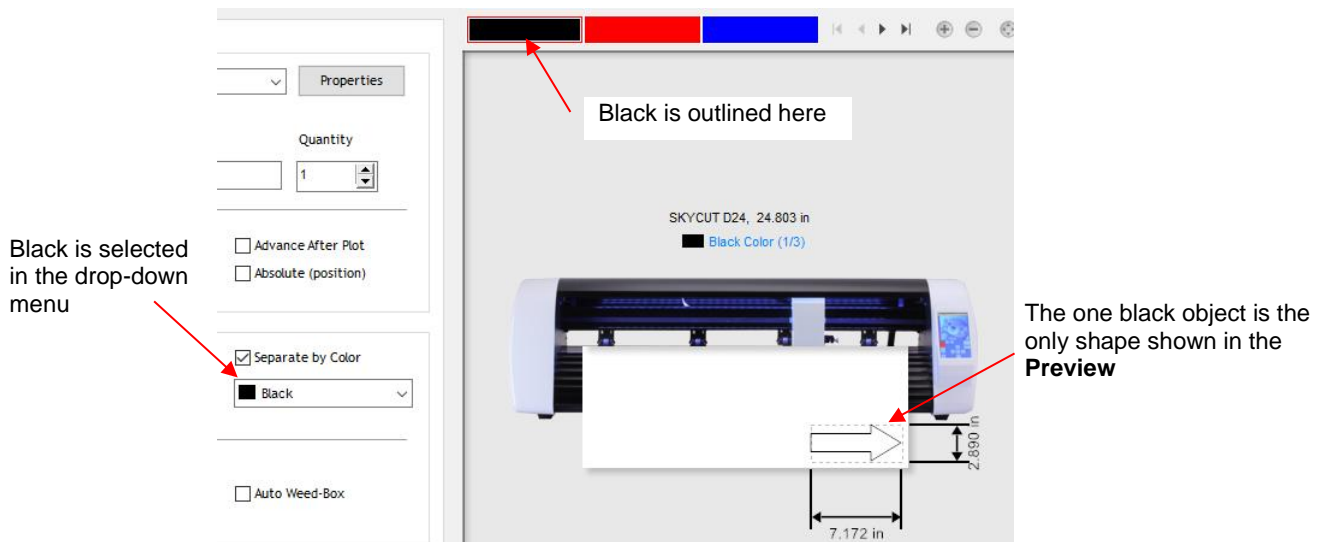

Black is selected in the drop-down menu

The one black object is the only shape shown in the **Preview**

- Switching to blue changes the window accordingly:

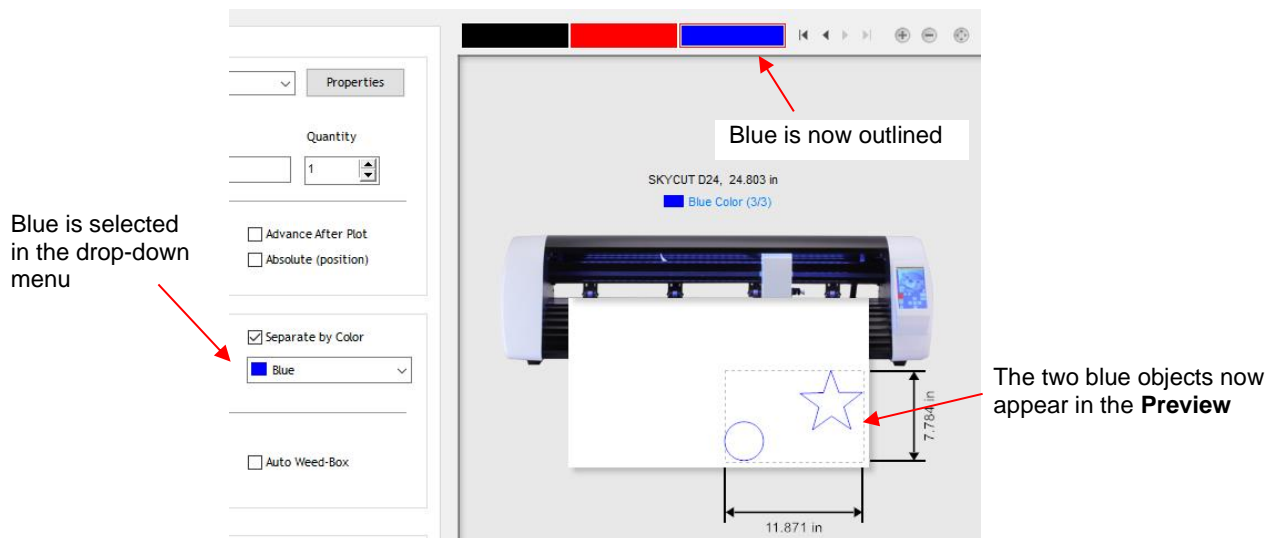

Blue is selected in the drop-down menu

The two blue objects now appear in the **Preview**

- Note that you can also change colors by clicking on those colored rectangles above the preview.

- ◇ **Option 4:** Select the colors in the **Vinyl Spooler** window.
 - In the **Send to be Cut** window, again click on the **Separate by Color** option. Then, click on **Spool All**:

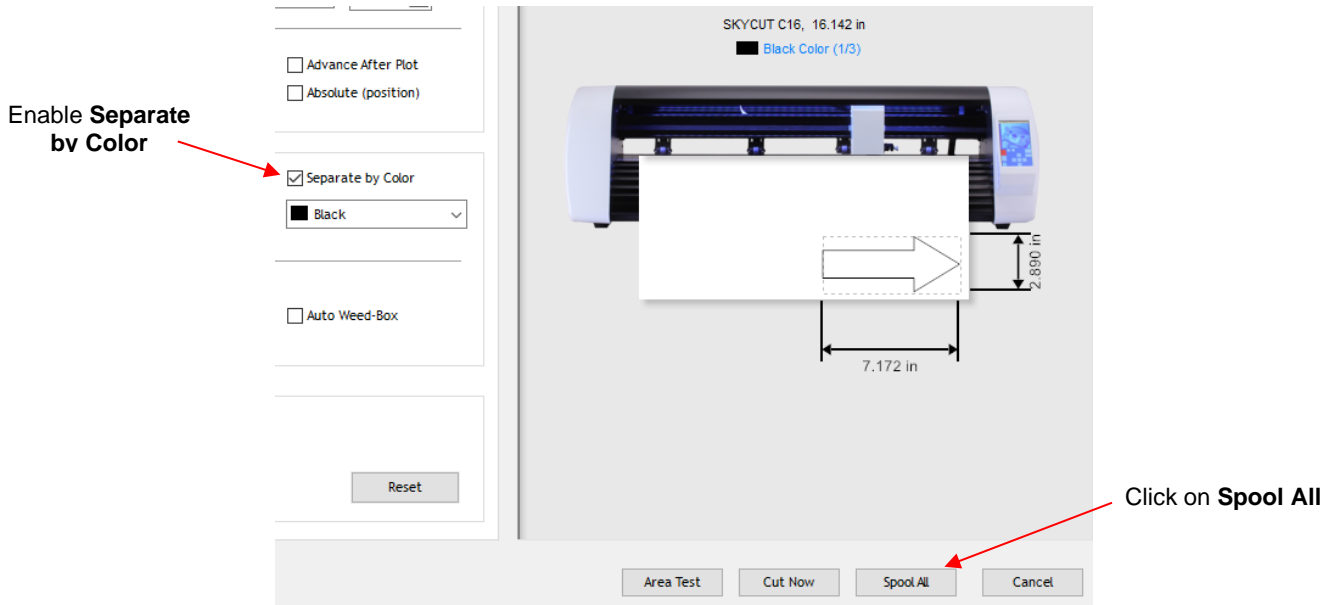

- In the **Vinyl Spooler** window, the job will appear at the top and queuing of each color will begin. In this example, *Red* is at the top of the menu and the red shapes appear in the **Preview**. Click on **Cut Now** to cut those shapes. Otherwise, click on either *Blue* or *Black*:

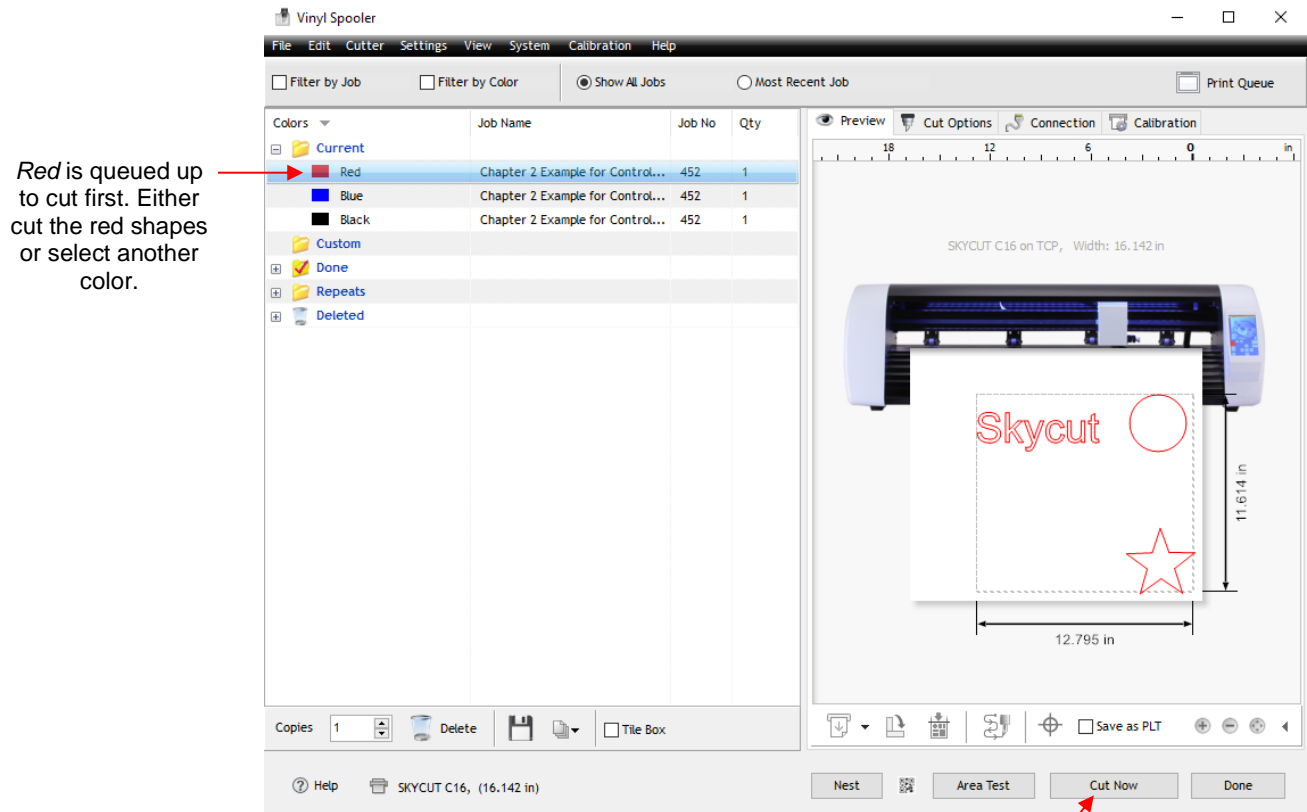

Click on **Cut Now** to proceed with cutting

- After the red shapes are cut, it will no longer be in the menu. The next color (*Blue*) will be selected and you can again choose to cut that color or select the third color (*Green*):

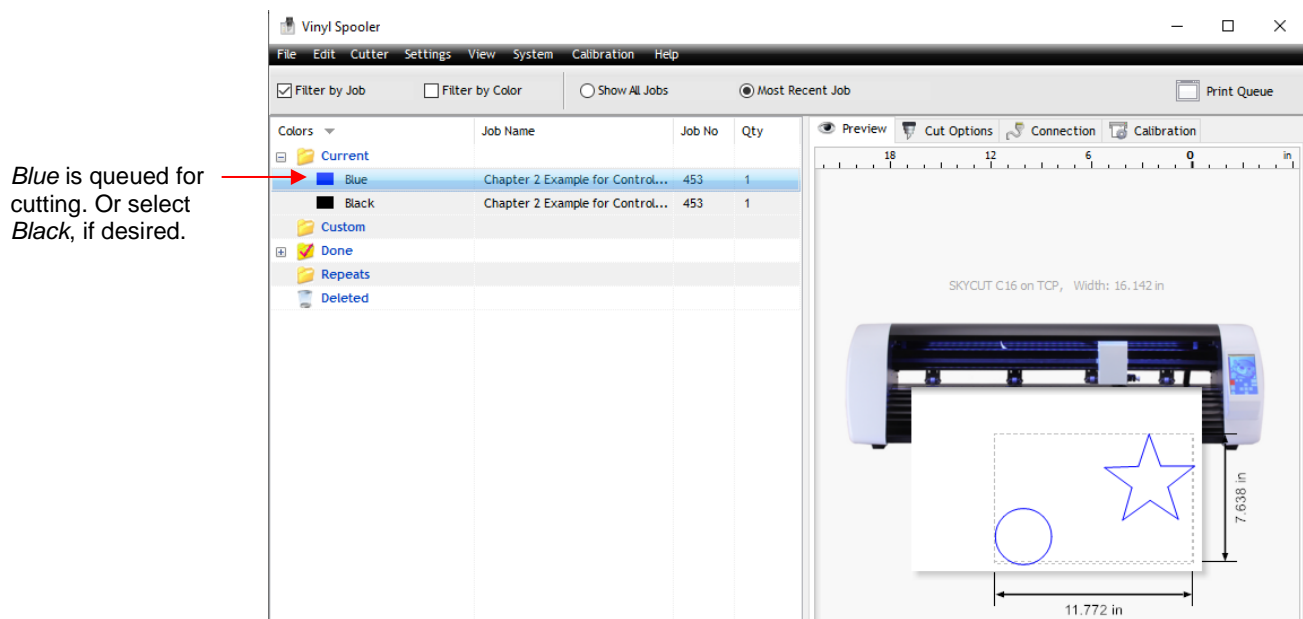

- After the last color is completed, the job is moved to the **Done** folder and can be repeated at any time:

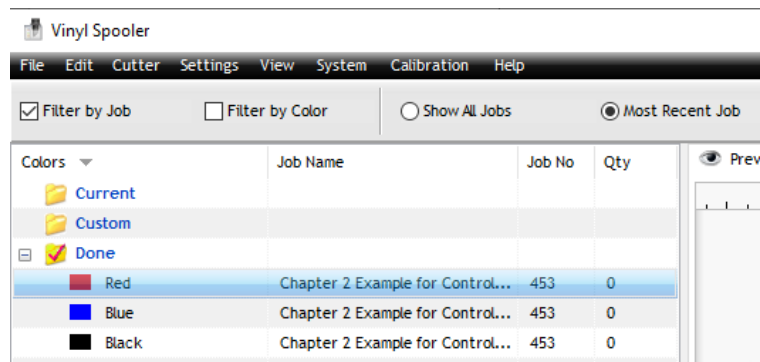

2.02.2 Controlling Where Shapes Will Cut

- This was briefly covered in *Section 1.13* where the **Rotate** and the **Absolute (position)** options were introduced.
 - ◇ **Default:** Moves the shapes to align with the origin you have set based on the blade tip.
 - ◇ **Absolute (position):** Cuts the shapes where they are positioned on the **Drawing Area**.
 - ◇ **Print and Cut (aka Contour Cutting):** Cuts the shapes relative to where registration marks are scanned:
 - This is the mode used when you want to print images on your printer and then have the Skycut cut them out.
 - Registration marks are printed, along with your images. The printout is placed into the Skycut and a built-in camera automatically locates and aligns with each printed mark. The Skycut will then cut out your shapes based on triangulation. This is far more precise than **Absolute (position)** because it takes into account not only any misalignment of your printout in the cutter, but also any errors in the printing. Most printers do not print images precisely in the location on the paper as they are located on the screen.

- Note that raster images (.JPG, .BMP, .PNG etc.) will need to be traced first so that cut lines are created. Section 3.04 will present an example.
- Refer to *Chapter 3* for complete instructions on calibrating the camera and examples of PNC applications.
- You can also rotate a design for cutting, relative to how it appears on the **Drawing Area**:
 - ◇ To rotate the project, go to **Send to be Cut** and mark the **Rotate** option:

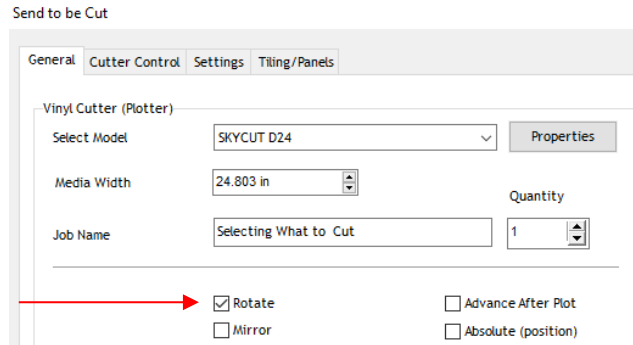

- ◇ For example, in a project with long text, it is more convenient to view and edit the text in a left-to-right orientation:



- ◇ However, when you then send this project to the **Preview** window, you will observe that it is too wide to cut from left to right on your Skycut:



- ◇ Marking the option for **Rotate** will then rotate the design and allow the project to cut:

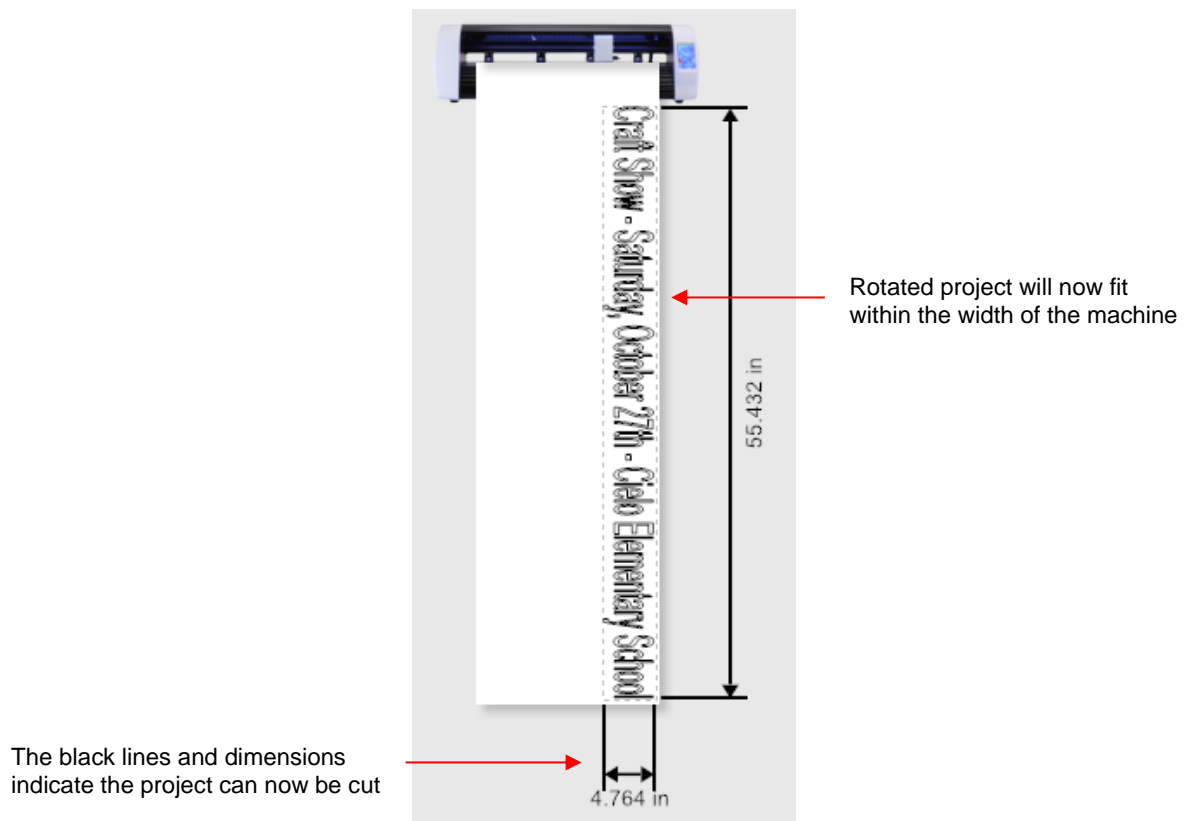

2.02.3 Selecting the Tool to be Used for Cutting

- To select the tool you'll be using, open the **Send to be Cut** window and click on the **Open Blade Settings Library** icon:

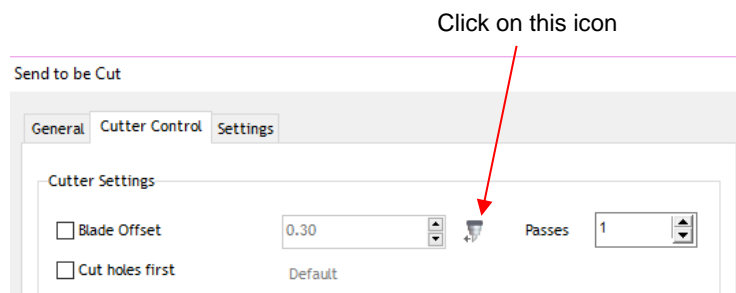

- The **Blade Settings Library** window will open. Click on the down arrow to the right of **Description** where you can access a drop-down menu for the **Blade Type**:

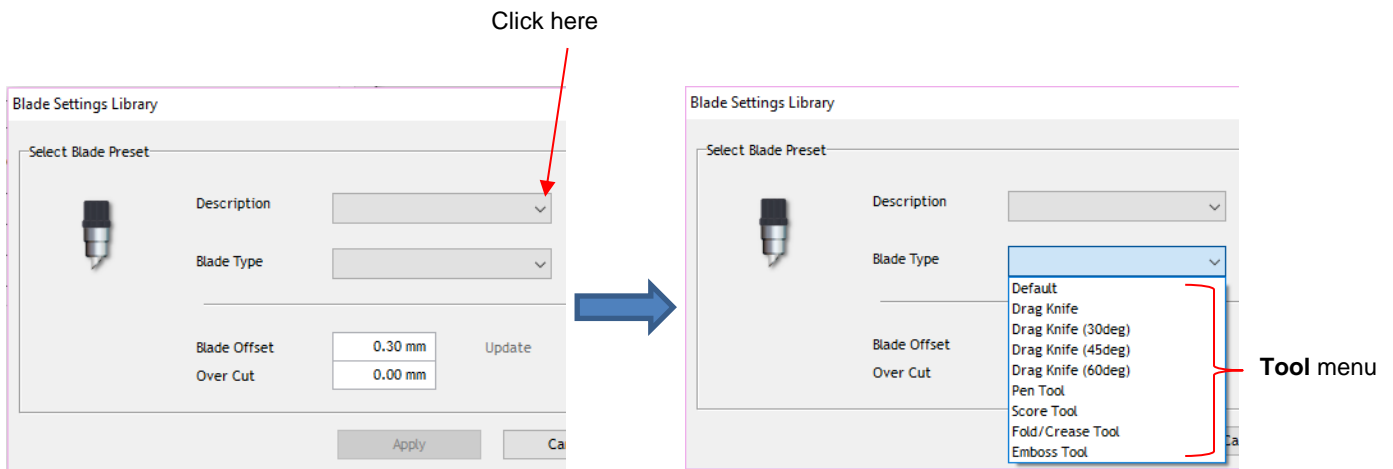

- Selecting one of the options, such as **45 degree blade** will display an image of the blade, the **Blade Offset** and **Overcut** assigned as a **Preset**:

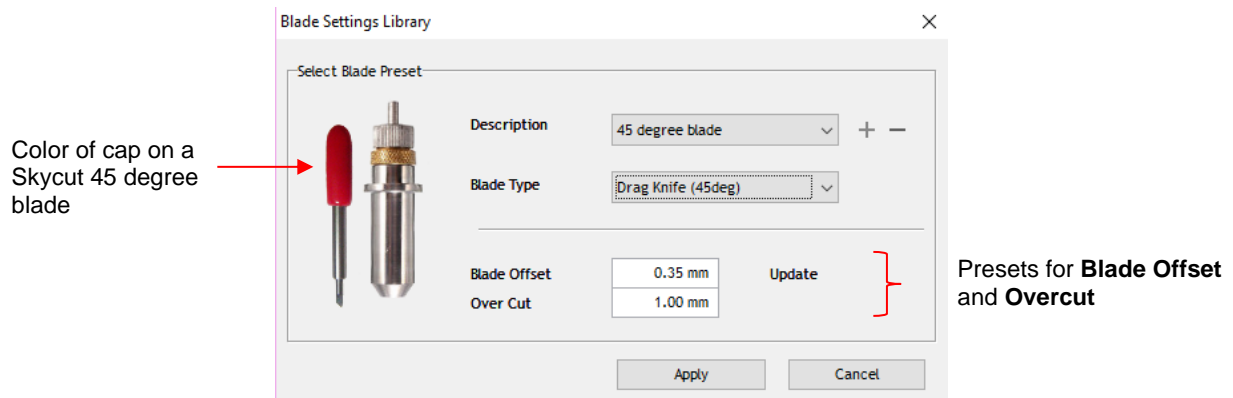

- *Sections 2.03.3 and 2.03.4* will explain **Blade Offset** and **Overcut** settings. *Section 2.04* will explain how to modify these settings, if needed and save as a **Preset**.

2.02.4 Determining the Cut Settings

- There are three locations in SignMaster where **Cut Settings** can be selected:
 - ◇ **Send to be Cut>Cutter Control** tab (which was covered in *Section 1.13*)
 - ◇ **Send to be Cut>General** tab
 - ◇ **Vinyl Spooler>Cut Options** tab
- **Send to be Cut>General**
 - ◇ Use this location when you need to assign different settings to different layers of your project. For example, let's say you wanted to use the embossing tool to score lines in a popup card, followed by cutting out the card itself. Or, another example would be using the test pen to draw a design and then cutting a contour around it. Under **General Options, Assign Tools by Color** is marked and then, below that in the **Cutting Tool Presets** section, individual colors can be highlighted and cut settings assigned by selecting a **Preset** or by clicking on **Edit**:

Mark Assign Tools by Color

General Options

Registration Marks

Separate by Color

Assign Tools by Color

Cutting Tool Presets

Color Name	Cutting Preset	Blade Type	Blade Preset
Red	(Default)		
Blue	(Default)		

Buttons: Edit, Reset, Include Color, Up, Down

◇ More details for using this feature are covered in *Sections 4.01.1* and *4.02.2*.

• Vinyl Spooler>Cut Options

◇ Use this option as an alternative to entering settings via the **Cutter Control** tab. It can be accessed from the **Properties** button in the **Send to be Cut** window. You will also use it in print and cut (contour cut) applications to check and adjust cut settings as well.

Send to be Cut

General Cutter Control Settings Tiling/Panels

Vinyl Cutter (Plotter)

Select Model: SKYCUT D24

Media Width: 24.803 in

Job Name: Selecting What to Cut

Quantity: 1

Properties

◇ In the **Vinyl Spooler** window, click on the **Cut Options** tab and the cut settings are located in the lower section of that window:

Section 2.03.3 → Blade Offset: 0.35

Section 2.03.4 → Overcut: 1.00

Blade type: Drag Knife (45deg)

Additional Options

Tool Select: Tool 0

Section 2.03.1 → Cutting Force: 50 g

Section 2.03.2 → Cutting Speed: (8) 400 cm/s

Section 2.03.2 → Travel Speed: (10) 500 cm/s

• These settings should be understood thoroughly, as you will be adjusting them often as you change materials or as your blade dulls over time. Note the prior screenshot shows the section number to go to for more information.

- **IMPORTANT:** At the time of this writing, **Travel Speed** defaults to the **Up Speed** on the control panel. Thus, this setting cannot be changed from within SignMaster. Additionally, both the **Cut Speed** and the **Travel Speed** will default to the values on the control panel when **Tool 1** (right side) is selected. Therefore, it is highly recommended that all settings be made on the control panel, at this time.

2.03 Cut Settings

- Before presenting the various settings, note that the **Force** and **Speed** settings can be set on the control panel itself. In order to cut from SignMaster and use the settings on the Skycut, uncheck these boxes in either of the two places where the settings can be made:

◇ **Send to be Cut>Cutter Control** window:

Uncheck these boxes if **Speed** and **Force** settings on Skycut are to be used

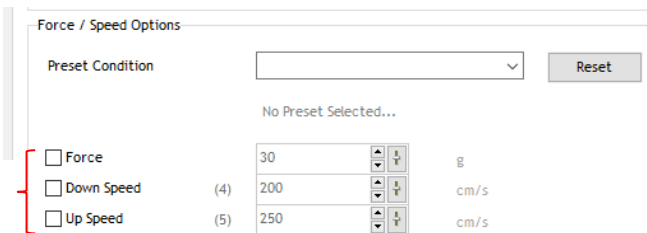

Setting	Value	Unit
Force	30	g
Down Speed (4)	200	cm/s
Up Speed (5)	250	cm/s

◇ **Vinyl Spooler>Cut Options** window:

Uncheck these boxes if **Speed** and **Force** settings on Skycut are to be used

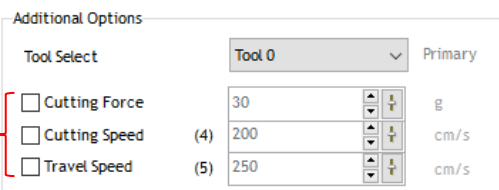

Setting	Value	Unit
Cutting Force	30	g
Cutting Speed (4)	200	cm/s
Travel Speed (5)	250	cm/s

2.03.1 Force

- **Force** (also called **Pressure**) ranges from 30 to 160 where the maximum of 160 represents ~2000g of cutting force. If it is set too low, the material cannot be cut. In fact, it is recommended that the minimum setting is always 30 or higher. However, if it is set too high, you will get bad cutting (even incomplete cutting at times) and tearing of the material. Always perform small test cuts before cutting your actual project and make adjustments in order to get a clean test cut before proceeding with your larger cut.
- Dull blades will need more force than new blades, thus anticipate increasing the force over the life of the blade.
- When cutting materials that can use either blade, the 45° blade (red cap) will need a little more force than the 60° blade (blue cap), because of the extra contact with the material being cut and because the 60° blade is cut much thinner, making it a “sliver blade.”
- As noted earlier, this setting can be made on the Skycut control panel instead. Press the **Force/Speed** icon



and then set the **FORCE** to the desired level.

2.03.2 Cut Speed and Up Speed

- **Cut Speed** (also called **Down Speed**) is how fast the blade travels while it is in the “down” or cutting position. **Up Speed** (also called **Travel Speed**) is how fast the blade travels while in the “up” position, such as when it is moving from the origin to the location of the first shape to cut or when moving from one cut shape to begin cutting another.
- The Skycut has 13 speed settings ranging from “snail’s pace slow” to “insanely fast.”

- ◇ The settings from 1 through 4 are the slow speeds and should be used when cutting dense difficult materials, such as chipboard, craft plastic, styrene, and balsa.
- ◇ The settings from 5 through 8 are medium speeds and should be used for easy-to-cut materials, such as cardstock, vinyl, iron-on transfer, and rhinestone template material.
- ◇ The settings from 9 through 12 are the fast speeds and are useful for engraving, embossing, and drawing. You may, however, find that some materials will cut well at the faster speeds.
- **Cut Speed** is usually more important to control since the blade may need more contact time with a particular material. **Up Speed** can usually be left quite high although, for print and cut accuracy, it may need to be lowered if there are many shapes to be cut from a printout.
- On the Skycut control panel, the default setting is to have the **Up Speed** and **Cut Speed** the same and referred to as **SPEED**. This can be adjusted by pressing the **Force/Speed** icon  and then setting the **SPEED** to the desired level. In order to enter a separate **Up Speed** on the control panel, refer to *Section 1.14.1*.

2.03.3 Blade Offset

- **Blade Offset** is the horizontal distance from the center of the blade shaft to the tip of the blade. A pen or engraving tool has an offset of 0 because the tip is centered with the center of the pen/engraving tool shaft. But a blade is different:



- If you set the **Blade Offset** to 0 when cutting with a blade, corners will be rounded. On the other hand, if it is set too high, bubbles will be cut on sharp corners:



Offset is too low:
corners are rounded



Offset is too high: bubbles
appear at the corners

- Currently it is recommended that a **Blade Offset** of between 0.25 – 0.35 be used for each of the three types of Skycut blades. Any time you order new blades, check for the recommended **Blade Offset** on the packaging. However, it's not unusual for blades to be slightly off-spec. Based on cutting a rectangle or square, increase or decrease the **Blade Offset** in increments of 0.1 or smaller until the shape has perfectly square corners.
- Alternatively, SignMaster has two built-in **Blade Offset** calibration routines which can be used to determine the best **Blade Offset** setting for the current blade in use. Here are the steps to access either one:
 - ◇ Select the material you want to use for testing, such as vinyl, paper, or cardstock. Note how much material will be needed for the test you select and add a few inches to these dimensions:
 - **Normal Test:** Width: ~9" (354 mm) Height: ~3.5" (89 mm)
 - **Quick Test:** Width: ~4.5" (114 mm) Height: ~1" (25 mm)

- ◇ Install the blade you wish to calibrate into the blade holder and mount the blade holder in the Skycut. Enter appropriate settings in SignMaster or on the Skycut control panel. Test cut a small shape to make sure the settings are correct.
- ◇ Go to the **Vinyl Spooler** window and select the **Calibrations** tab.
- ◇ Click on the **Blade Offset** icon and a new window opens:

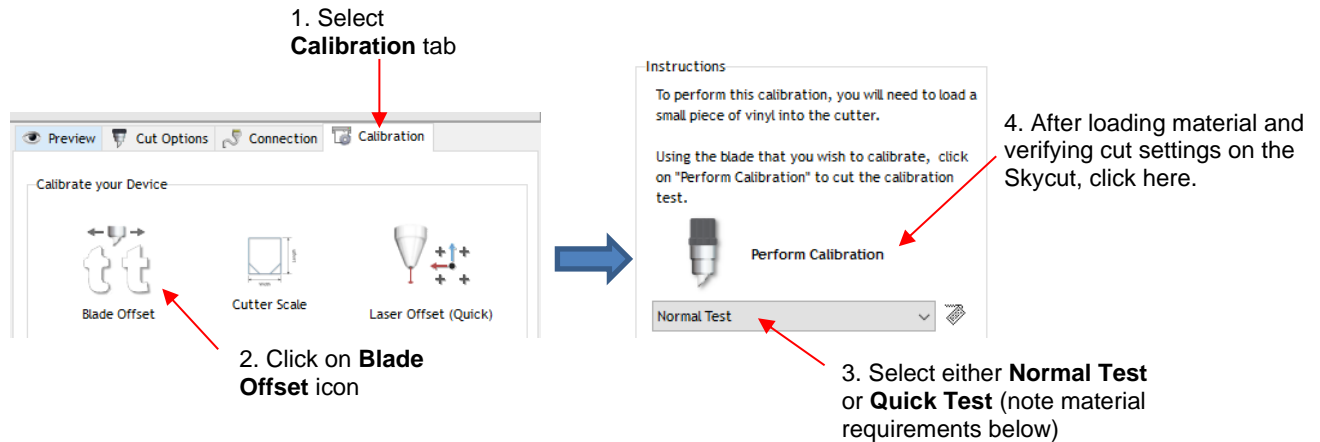

- ◇ In both tests, the instructions on the screen will guide you on how to enter the best result and then will display the recommended **Blade Offset** to use. This new **Blade Offset** value will then be updated in the cut settings. Instructions on how to add this setting as a **Preset** are covered in *Section 2.04*.

2.03.4 Overcut

- **Overcut** is related to **Blade Offset** in that it isn't needed when using a pen, embosser, engraver, and so forth, because the tips of those tools are aligned with the center of the tools themselves. However, leaving **Overcut** at 0 when using the blade holder will result in large shapes not quite closing:



Overcut is too low:
paths do not close

- In some cutting programs, **Overcut** is not a separate setting but rather automatically calculated and applied based on the **Blade Offset** entered. However, in SignMaster, you can enter an actual **Overcut** setting and should do so any time a blade is used.
- In general, the blade type doesn't greatly affect the **Overcut** required. Try using 1.00 mm. In the event you cut a large closed shape, like an 8" circle, you may find that you'll need to increase **Overcut** to 2.00 mm.

2.03.5 Passes

- The **Passes** setting causes each individual path to be cut the set number of passes before the blade moves to the next path to cut. This is better than just repeating the entire cut as each repeated pass is cut with the blade held down throughout the repeated passes, resulting in cleaner cutting.
- In general, when increasing **Passes**, the **Force** setting can be decreased. For example, you may find a cardstock that requires a **Force** of 55 to cut in a single pass will only need a **Force** of 45 if cutting in two passes.
- **Passes** is recommended in the following situations:
 - ◇ Cutting thicker denser materials, such as chipboard, where multiple passes allow the blade to progressively "carve" through the material

- ◇ Cutting certain fibrous materials, such as fabric, where a second pass will ensure that all of the fibers have been cleanly cut
- ◇ Cutting intricate or detailed shapes (such as script titles) from certain materials, such as heavy or textured cardstock, where a single pass may leave certain spots not cleanly cut
- ◇ Cutting rhinestone template material where a second pass results in much cleaner weeding of the cut circles
- You will find a **Passes** setting in the **Send to be Cut>Cutter Control** window, under the **Cutter Control** tab:

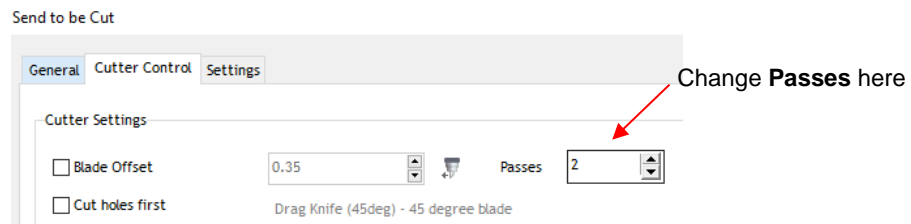

- ***IMPORTANT:*** In the current version of SignMaster Pro, **Passes** does not work if **Assign Tools by Color** is activated. Therefore, if you have a project requiring separate settings for layers, such as a score and cut project, the **Passes** function on the Skycut's control panel should be used instead.
- If you are only using the left side or only the right side, press the **USB** button on the **Main Screen** and you will see a **Passes** button in the window which opens:

NOTE: If your screen does not have **Passes Set** displayed, please go to *Appendix C* for activation instructions.

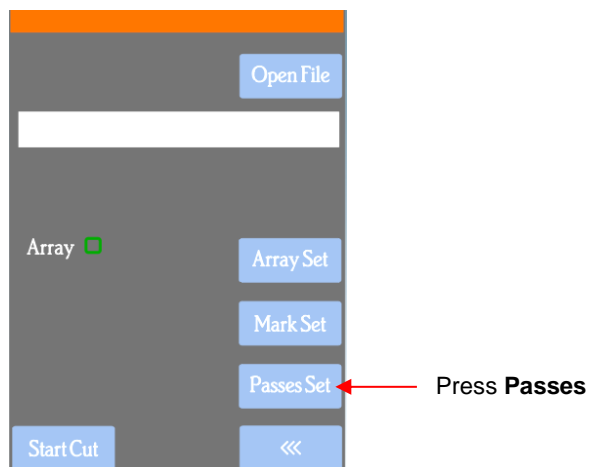

- ◇ Press the **Passes** button to open the following screen where you can turn on the **Passes** function and enter the desired number of repeats:

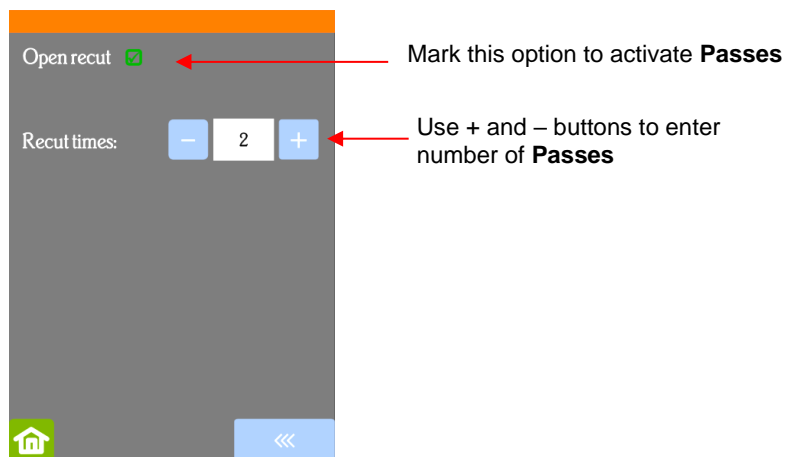

- If you are planning to use both heads, make sure **Use Double Head** is activated on the control panel's **Main Screen**. If you do not see this option (as shown in the following screenshot), click on **Set>Advanced settings>System mode** and select **double**. Then, back on the **Main Screen**, the following options should now appear:

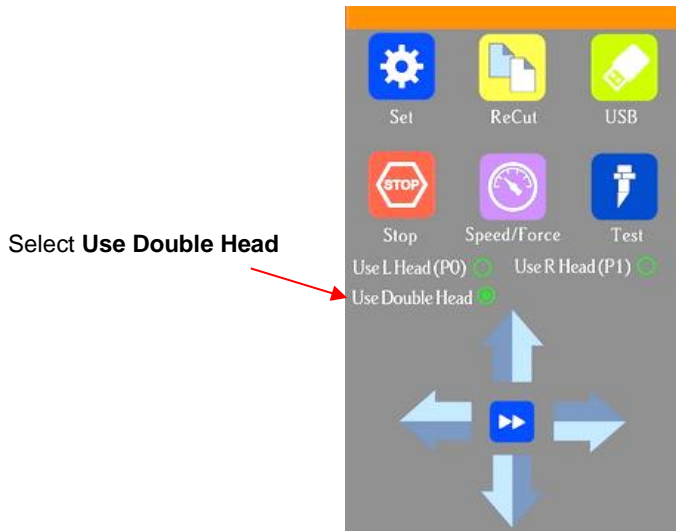

- Press the **USB** button on the **Main Screen** and you will see a **Passes** button in the window which opens:

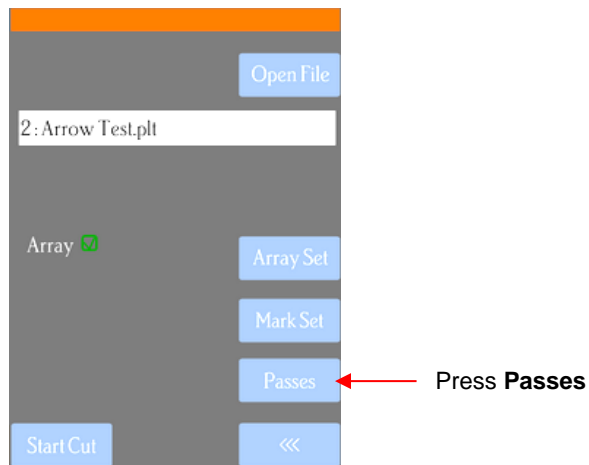

- Press the **Passes** button to open the following screen:

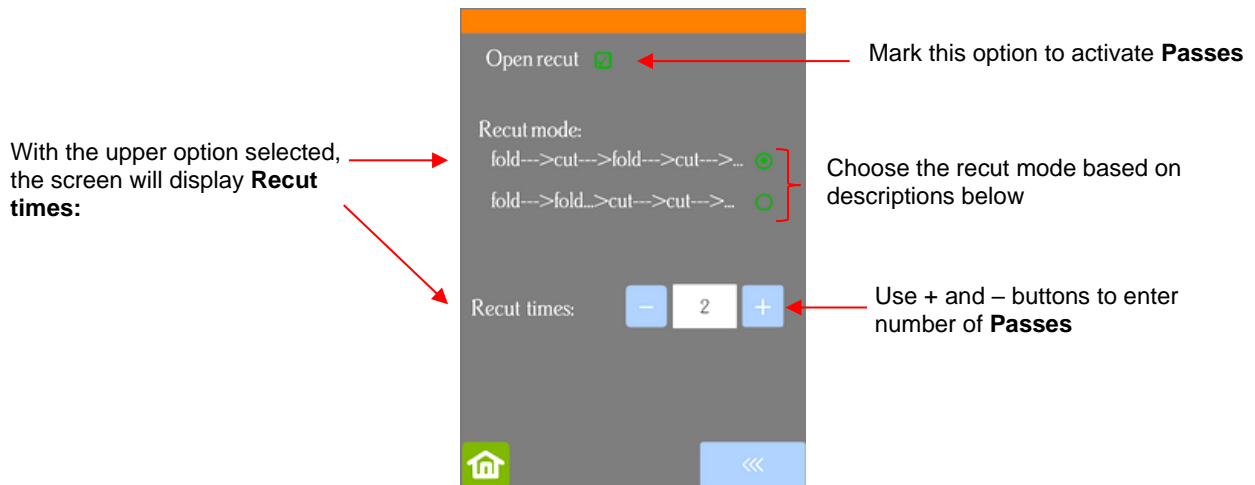

- Recut mode has two options:
 - ◇ If the upper option is marked, then the screen shows a setting called **Recut times** which you set based on the number of passes you want both sides to perform. Note that it will execute both sides' shapes before doing additional passes.
 - ◇ If the lower option is marked, the screen changes and you can enter different passes for the two heads to perform. Note that it will execute the passes on one side before executing the passes on the other side:

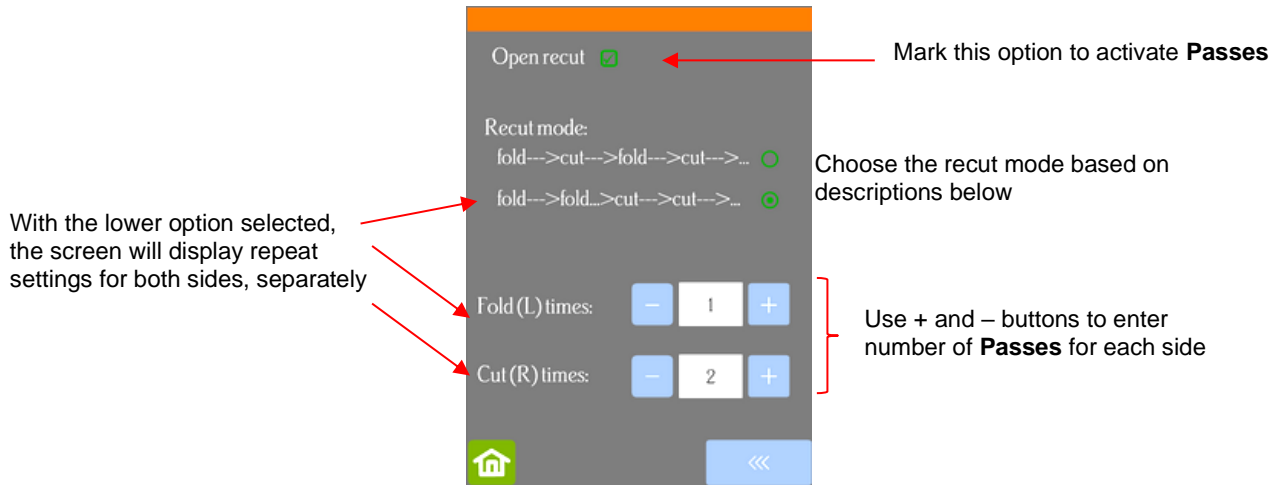

- IMPORTANT:** Currently the **Open recut** option will default to off whenever the Skycut is first powered on. Thus, make a mental note (or, even better, put a Post-It note on your cutter) to turn this option on when using multiple passes in dual head operations.

2.04 Presets

- Presets allow you to save your settings for a particular blade type or material.

2.04.1 Saving a Preset for a Blade Type

- Let's say you conducted the calibration for **Blade Offset** in *Section 2.03.3* and determined it to be 0.40 for your red capped blade. To save this setting as a preset, use the following steps:
 - ◇ Go to the **Send to be Cut>Cutter Control** window and click on the icon to the right of **Blade Offset** to open the **Blade Settings Library**:

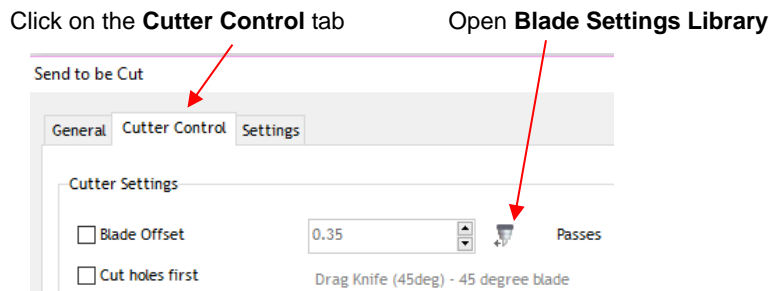

- ◇ In the **Blade Settings Library**, click on the **+** icon to the right of **Description** and a window will open where you can enter the name for your new preset:

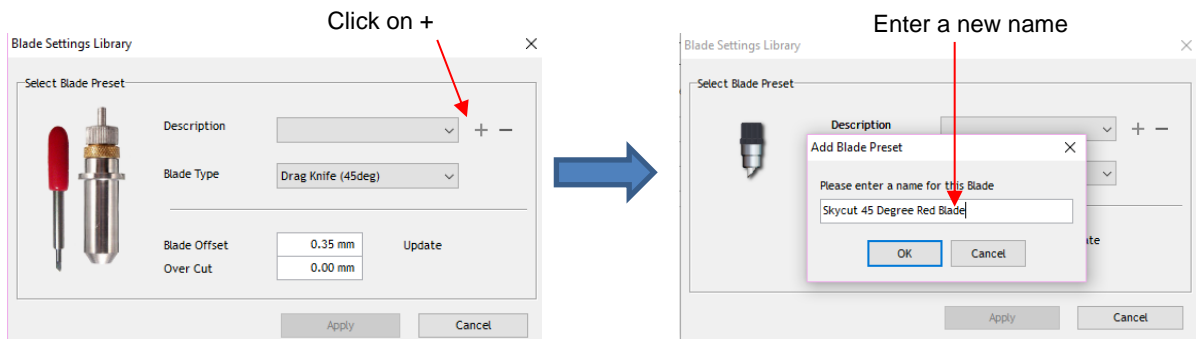

- ◇ Click on **OK** and then select which blade type you are using for this new preset Enter the new **Blade Offset** and **Overcut** values. Then click **Update**:

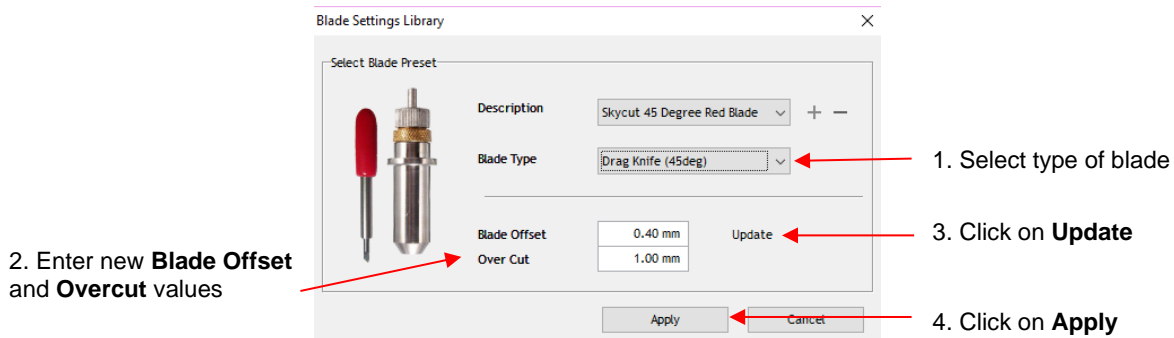

- ◇ Click on **Apply** to close the **Blade Settings Library**. The new preset will now be available for selection in the **Description** menu.

- If you need to delete a preset, select it from the **Description** menu and click on the “-” icon to the right.

2.04.2 Saving a Preset for a Material

- ***IMPORTANT:*** As was noted in *Section 2.02.4, Up Speed (aka Travel Speed)* is not functional in SignMaster and both speed settings do not apply with **Tool 1** (right side) applications. Thus, unless using a preset with **Tool 0** (left side) cutting, it is recommended that presets be made on the control panel.
- Before proceeding, note the following:
 - ◇ Even if you are not using the right side for a particular material, make sure the control panel is set to **Double** under **Set>Advanced Settings**. Otherwise any presets entered will be automatically assigned to the right side.
 - ◇ Because settings for any given material or application would need to be entered twice to make those settings available for both right and left sides, consider which side you might always choose to use. For example, if you always use the left side for cutting and the right side for scoring, then only enter those settings for those sides.
 - ◇ There’s a maximum of 10 presets allowed, thus consider which materials or applications are most important to you.
- To create a preset:
 - ◇ Verify that **Use Double Head** is selected on the main control panel screen:



- ◇ Press the **Force/Speed** icon  to open the **Force/Speed** screen:

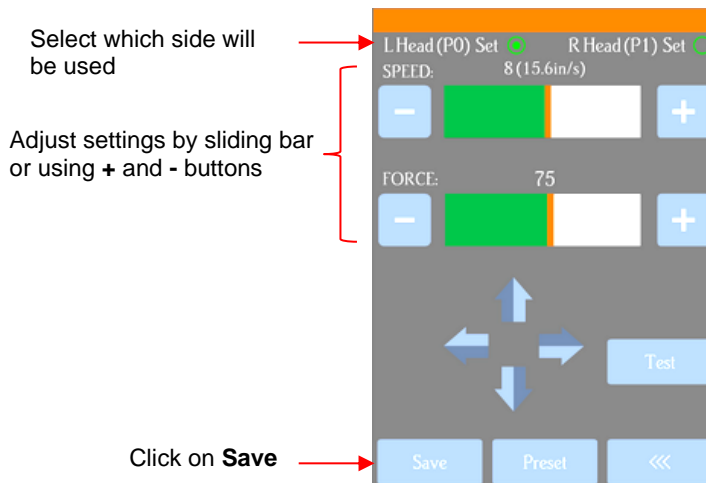

- ◇ Make the necessary changes to the **SPEED** and **FORCE** settings. Select **Save** and the following screen opens:

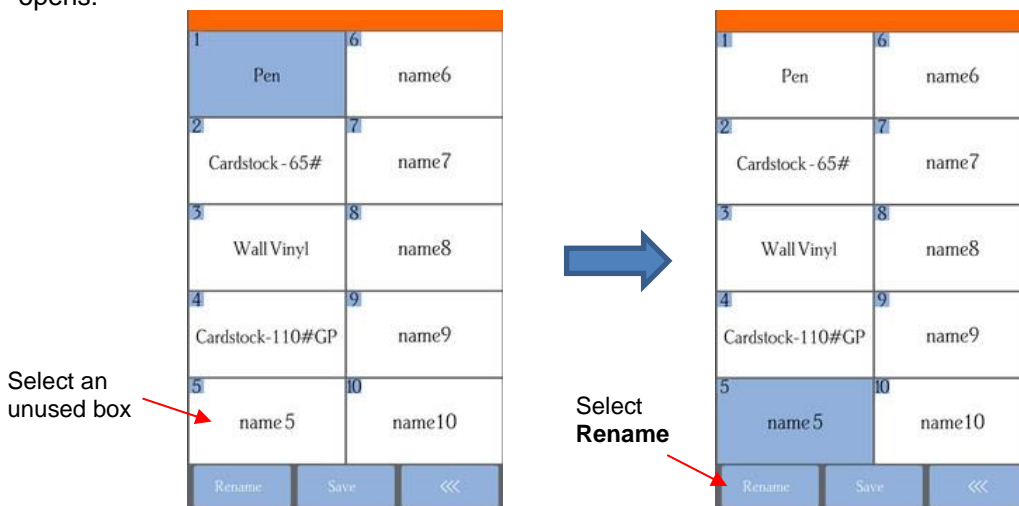

- ◇ Press one of the unused preset boxes, e.g. *name5*, and it will turn blue indicating it is highlighted. Select **Rename**.
- ◇ A window opens where you can enter the name for the new **Preset**. The characters are entered in the same manner as the **Password** entry window in *Section 1.12.2*. Note that there is a 15 character limit. Click on **OK** when done:

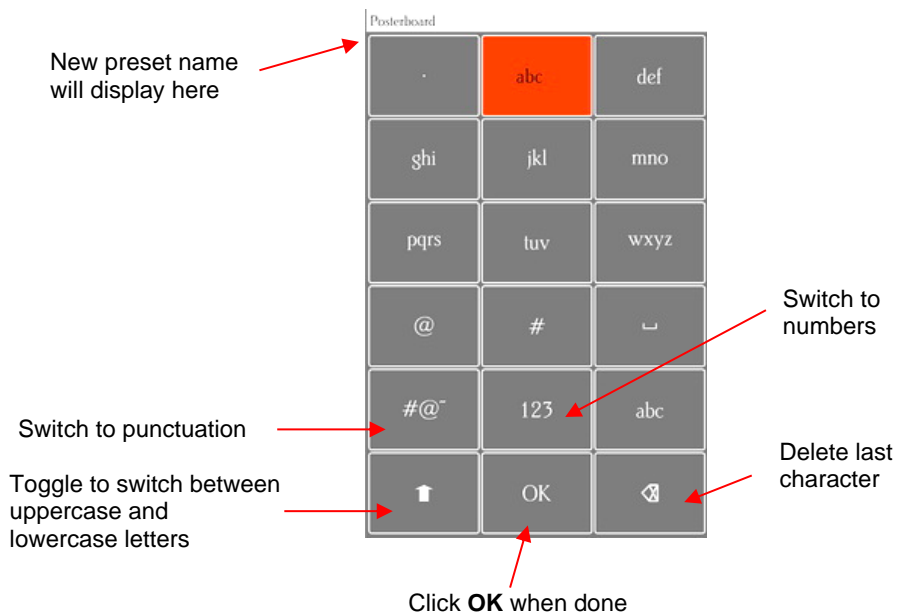

- ◇ You will now see the name of your new preset and you can press **Save** to add it to the saved presets with the **FORCE** and **SPEED** you set. You will be returned to the **Force/Speed** screen.

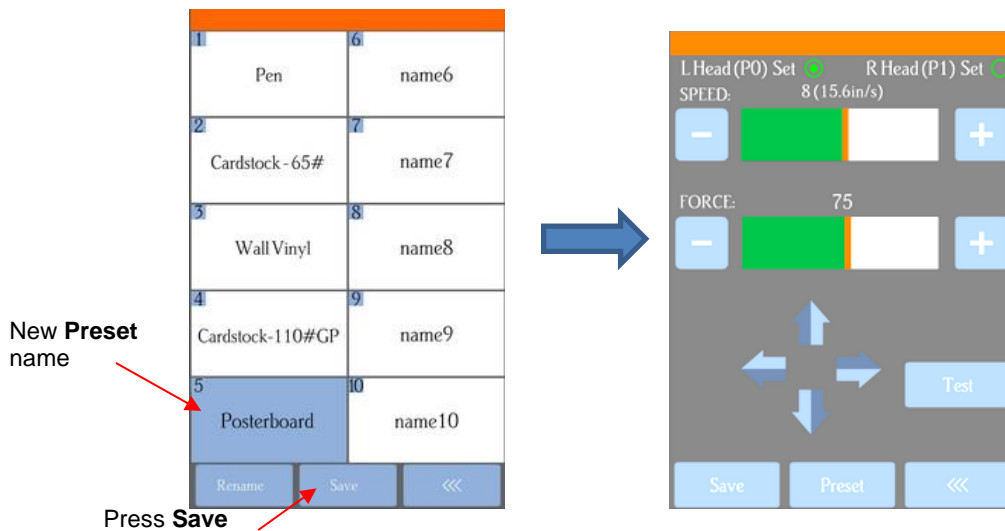

- ◇ To verify the preset or to select a different preset, press **Preset**. The **Preset** window opens where you can see all of the **Presets**, along with the settings for those presets. In that window you can also select a different preset. Then you can select **Rename** to edit its name or select **Load** to select that preset's **Force** and **Speed** into the **Force/Speed** screen. Note that if you need additional **Passes** when cutting a material, they will need to be set using the instructions from *Section 2.03.5*.

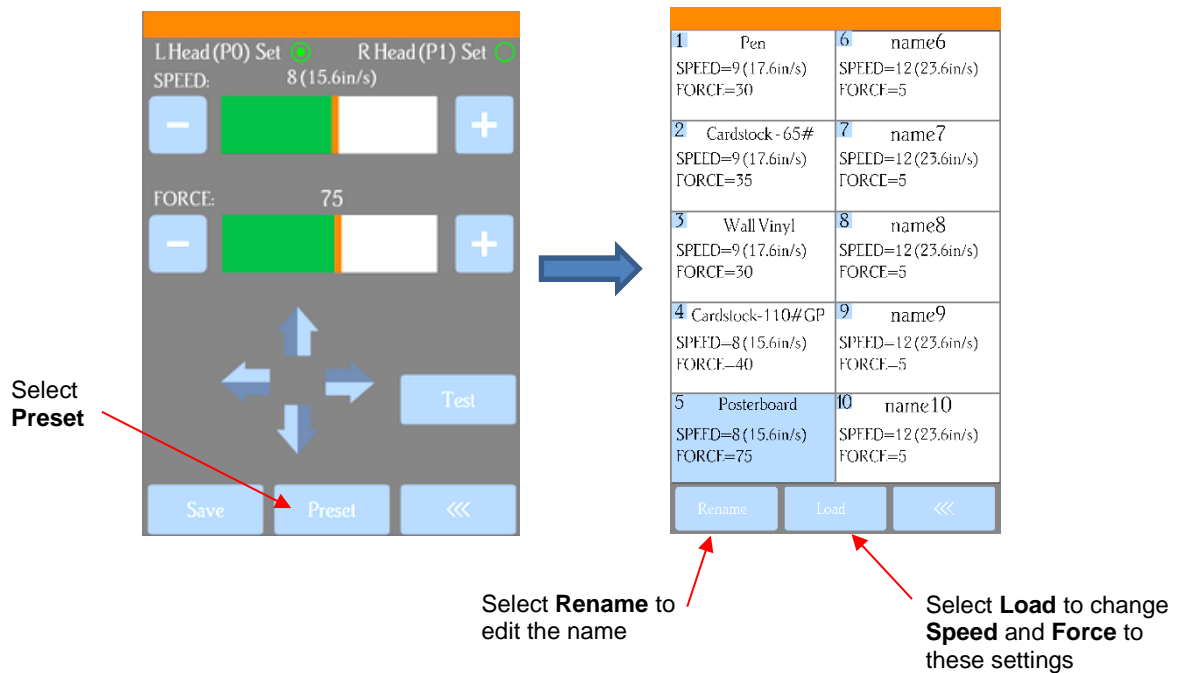

2.05 Setting the Origin before Cutting

- Before you cut, you should check to see where the blade tip is located in relation to the material so that the shapes will cut in the appropriate location.
- **IMPORTANT!** The Skycut D24 has a maximum cutting width of 24 inches. If you move the head too far to the left to begin the cut and your project is wide, you may exceed the left side limit and cutting will stop at that point with no option but to abort.
- To set the origin, press the arrow buttons on the main screen of the control panel. Remember that the middle button can be toggled between regular speed and a slow speed for more control:

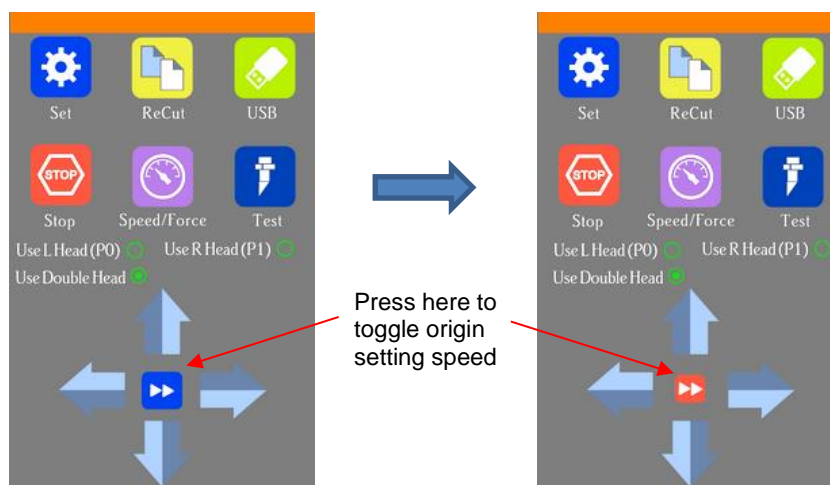

- In general, you set the origin near the lower right corner of the material, as you did during your initial test drawing in *Section 1.13*.
- If you ever choose to have **Use R (Head) (P1)** selected on the control panel, the origin will be base on the right-side tool, verus the normal left side:



Press here to switch to right side only.

The origin will now be based on the tool mounted on the right side of the Skycut D

2.05.1 Setting an Origin Using the Camera

- In the event you need to set an extremely precise origin, the Skycut's built-in camera can be used:
 - (1) Go to *Section 3.03* and perform the camera calibration.
 - (2) Choose where you want the origin to be set. You'll need an "origin target" to use when the camera takes a photo. It can be a dot on your material, the corner of your material, the intersection of grid lines on the mat, etc. If you do choose the latter, make sure there's a way to clearly distinguish which intersection you want to use.
 - (3) Note that whether the right or the left blade holder seat is moved to the origin you set depends on which mode you've selected on the **Control Panel**:
 - ◇ **Use L Head (P0)**: will align the left blade holder seat
 - ◇ **Use R Head (P1)**: will align the right blade holder seat
 - ◇ **Use Double Head**: will align the right blade holder seat (thus, you may need to temporarily switch to **Use L Head (P0)** to set the origin and then switch back to **Use Double Head** for a dual tool application).
 - (4) On the Skycut's **Main Screen**, use the arrows to move the center of the blade holder roughly over the origin target. In this example, a dot will be used.
 - (5) Select **Set** and **Camera**. In the **Camera Screen**, press **OK**. A photo will be taken and displayed. If needed, press **X3** so that you are zoomed out and able to see the origin target (dot) in the photo:

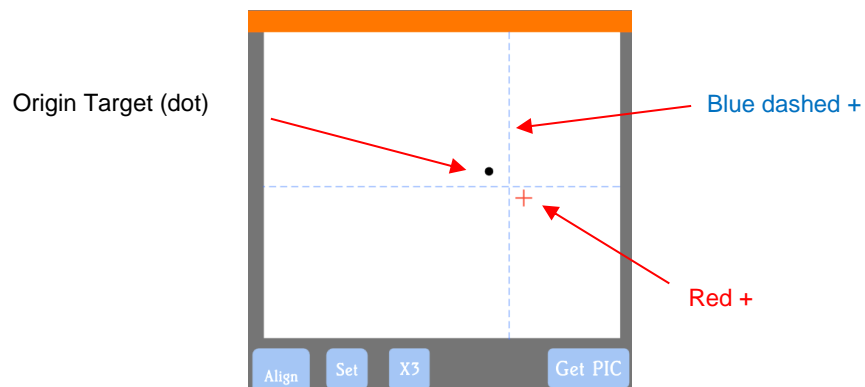

(6) Press the center of the origin target in the photo so that the red + will be moved approximately over it:



(7) Press **OK**. In the new photo, the blue dashed + should be close to the origin target. Press **X3** to zoom in:

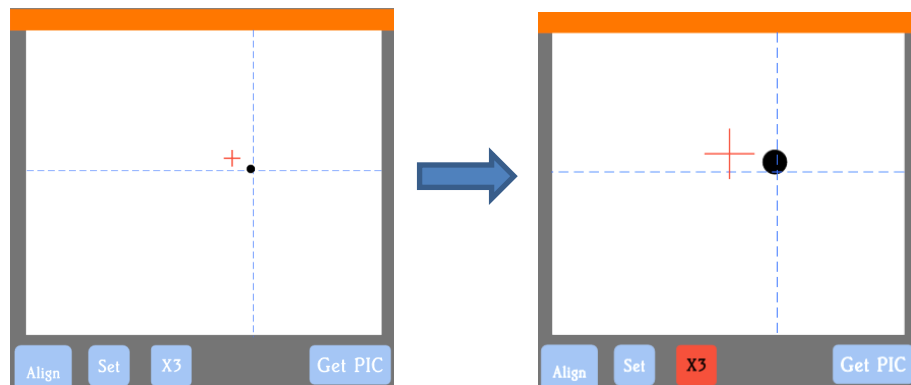

(8) Use the arrow buttons to move the red + as close as possible to the center of the origin target:

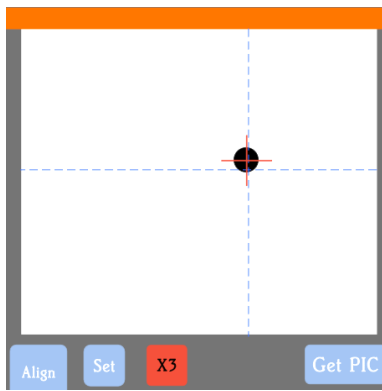

(9) Press **OK**. At this point the blue dashed + should be centered with the origin target:

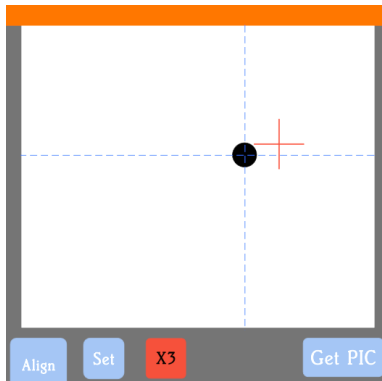

(10) Press the **Home** icon to return to the **Main Screen**. The head should move so that the blade holder is now located over the origin target and you can proceed with the cutting process.

2.06 Other Cut Setting Functions

- There are other functions and features available in the **Send to be Cut** window that may be useful depending on your application. Some have already been covered. Some will be covered in this section. Others will be covered in later parts of this manual. Note the section numbers for reference:

<p>Section 2.02.2</p> <p>Section 2.06.2</p>	<p><input type="checkbox"/> Rotate</p> <p><input type="checkbox"/> Mirror</p>	<p><input type="checkbox"/> Advance After Plot</p> <p><input type="checkbox"/> Absolute (position)</p>	<p>Section 2.06.1</p> <p>Section 2.02.2</p>
General Options			
<p>Section 3.03</p>	<p><input type="checkbox"/> Registration Marks</p>	<p><input type="checkbox"/> Separate by Color</p> <p><input type="checkbox"/> Assign Tools by Color</p>	<p>Section 2.02.1 Option 3</p> <p>Section 4.01.1</p>
<p>Section 2.06.3</p>	<p><input type="checkbox"/> Auto Speed-Weed</p>	<p><input type="checkbox"/> Auto Weed-Box</p>	<p>Section 2.06.3</p>
Text Options			
<p>Section 2.06.3</p> <p>Section 2.06.4</p> <p>Section 2.06.3</p>	<p><input type="checkbox"/> Easy-Lift Weed Marks</p> <p><input type="checkbox"/> Weld Text</p> <p><input type="checkbox"/> Speed-Weed Text Only</p>	<p style="text-align: center;">Reset</p>	

2.06.1 Advance Mode

- The **Advance After Plot** option in SignMaster Pro is actually controlled on the Skycut itself. The function can be opened by going to **Set>Advance Mode** on the control panel.

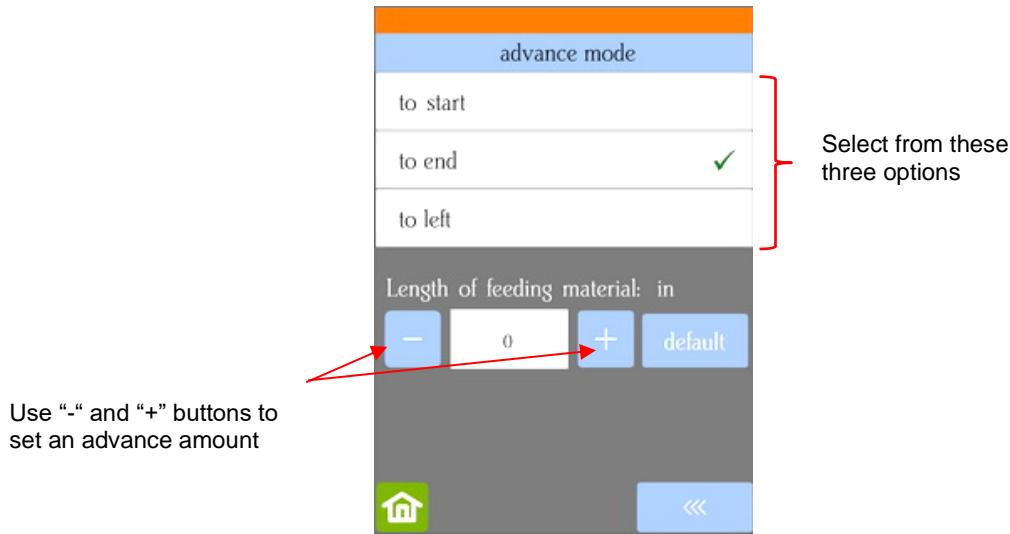

- ◇ **to start** will cause the blade holder to return to the origin after cutting.
- ◇ **to end** will cause the blade holder to advance forward to the end of the cut project.
- ◇ **to left** will cause the blade holder to move to the left of the cut project.
- ◇ The settings below the option are activated when choosing either **to end** or **to left**. You can enter a specific distance for the blade holder to advance. This is useful when cutting repeats of the same project because it allows for the origin to be set automatically for the next repeated cut.

2.06.2 Mirror

- Checking the **Mirror** option will apply a horizontal mirror to the shape (s) before cutting. This is useful in applications such as:
 - ◇ Cutting HTV in which the material is placed faced down so that the heat protection layer is not penetrated by the blade
 - ◇ Cutting vinyl to be applied to the inside of a car or home window but primarily viewed from outside of the window
 - ◇ When cutting certain non-homogenous paper materials in which cutting upside down yields cleaner results

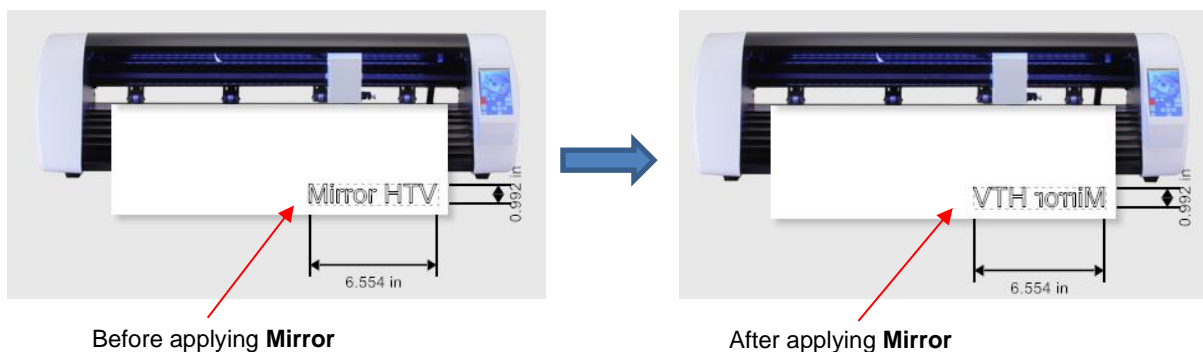

2.06.3 Weeding Options

- For those cutting vinyl and HTV, the weeding options in SignMaster are worth noting.

◇ **Auto Weed-Box:** Marking this option places a single weed box around the entire project:

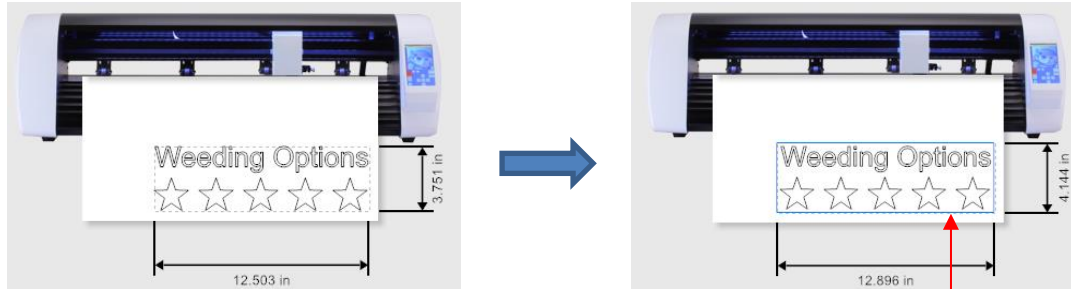

Before applying **Auto Weed-Box**

After applying **Auto Weed-Box** – blue border around design indicates weed cut

- Note: to change the size/offset of the weed box around the design, click on the **Settings** tab and adjust, as desired:

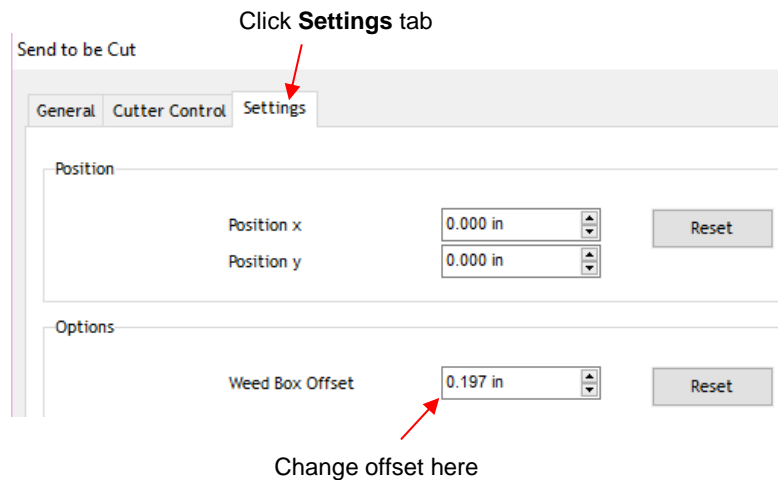

◇ **Auto Speed-Weed:** Marking this option places a single weed box around the entire project with an additional horizontal weed line through the middle:

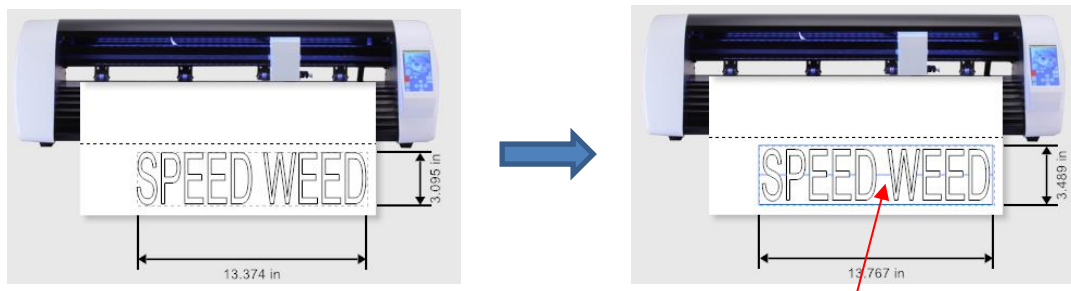

Before applying **Auto Speed-Weed**

After applying **Auto Speed-Weed** – blue weed box plus horizontal weed cut in the middle

◇ **Easy-Lift Weed Marks:** Marking this option adds hooked lines to shapes with internal paths to make it easier to lift with a weeding tool:

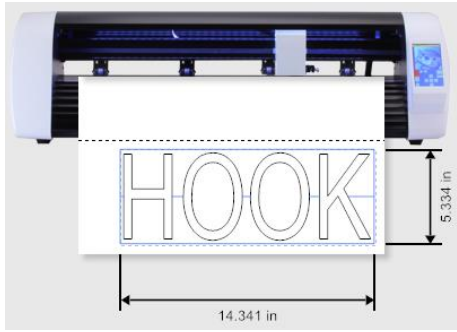

Before applying **Easy-Lift Weed Marks**

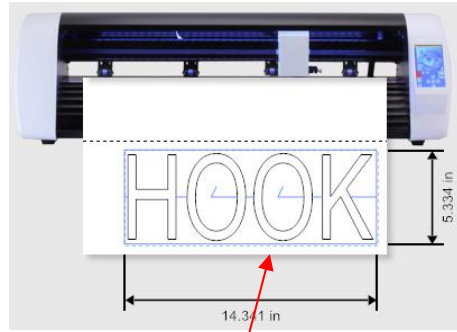

After applying **Easy-Lift Weed Marks** – hooked cuts are added to internal shapes for easy lifting during the weeding process

- ◇ **Speed-Weed Text Only:** Mark this option when your design has a combination of both text and other shapes so that only the text will have **Speed Weed** applied:



Before applying **Speed-Weed Text Only**

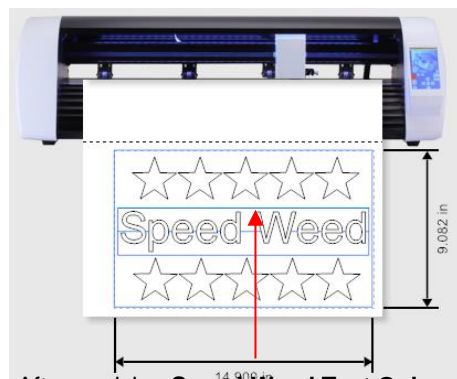

After applying **Speed-Weed Text Only** – text object has additional weed box plus horizontal cut through the middle

2.06.4 Weld Text

- For script fonts, the **Weld Text** option will remove overlap between letters so that a word will cut as one object. For example, if you go to **View>Wireframe**, you can see the overlap that will be cut when a script font is used:

Weld Text

- You have the option to select the letters and apply the **Weld** function under the **Shaping and Welding**

Tools , thus removing overlap between letters:

Weld Text

- This, however, means you cannot change the font used or alter the spacing of the letters, etc., without applying **Undo**. Therefore, the **Weld Text** option allows you to cut the text as if the **Weld** function has been applied:

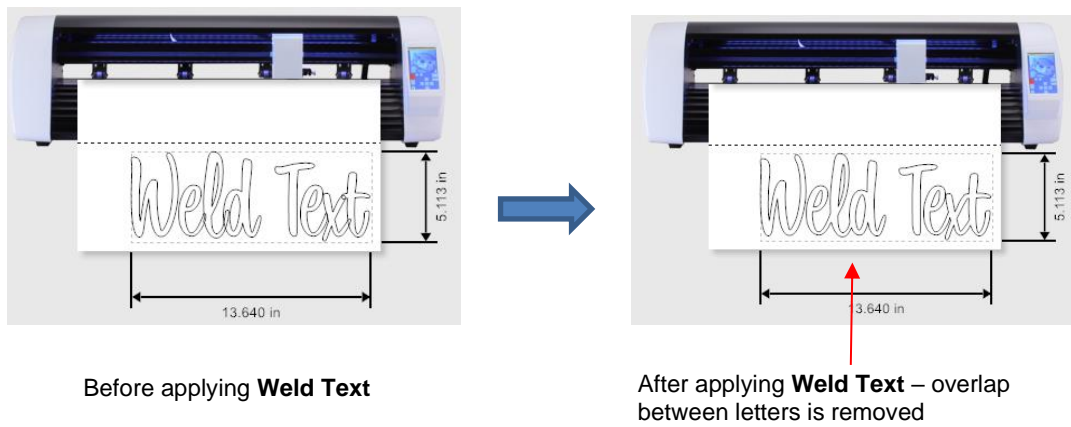

2.07 Important Checklist Before You Cut!

- Do you have your material on the mat and the mat inserted into the Skycut? (Note: materials with a backing sheet, such as vinyl and iron-on transfer do not require a mat for cutting)
- Have you selected pinch wheels positions that are roughly the same distance from the outside edges of the cutting mat (or material, if not using the mat)?
- Are the pinch wheels in use centered over grit shafts (located below the white rectangle labels)?
- Do you have the pinch wheel lever raised (so that the pinch wheels are down)?
- Have you set the blade length/exposure based on the thickness of the material you are cutting?
- Do you have the blade holder firmly mounted in the blade holder seat and the blade tip at the correct height above the material?
- Have you set the **Origin** (location of the blade tip) at the bottom right corner of your material (or wherever you need the origin to be)?
- Have you selected the correct mode on the control panel (**Left** versus **Right** versus **Double Head**)?
- Have you set the **Force**? And the **Speed**? Do you need to do a test cut?
- Do you need to turn on **Passes** for this material?
- Have you selected the correct **Blade Offset** for the blade you are using?
- Do you see the correct shapes in the preview window?
- Do you need to select **Rotate**, **Mirror** or **Absolute (Position)** options? Do you know, with confidence, where your shapes are going to cut?
- Do you need to apply any weeding options?

2.08 Scale Calibration

- If you were to cut out any particular shape, for example, a 10" x 10" square, you might find that it actually measures 9-15/16" x 10-1/32". It will be very close to 10" x 10" but perhaps just slightly smaller or larger in either or both dimensions. Now this might be perfectly acceptable for the type of cutting you do. Therefore, it may not even be necessary to do this particular calibration. However, if you do want to make sure your shapes are cut precisely to scale, the following procedure will allow you to calibrate your Skycut.
- The calibration process can be conducted in inches, cm, or mm. Both mm and inches will be presented here. In general, it is recommended that mm be used, however, if you do not have a metric ruler, then you can use inches instead.

- Before beginning this calibration, make sure the **Scale** setting on the Skycut itself is still set to 1.0 and 1.0. On your Skycut control panel, go to **Set>Advanced Settings> Scale**. The following window opens where you can check the current **X Scale** and **Y Scale** values:

Verify **X Scale** and **Y Scale** are both set to 1.0000

Use the **+** and **-** buttons to adjust the numbers, if needed



- Return to the main screen. Then pick one of the two following sections and follow the instructions.

2.08.1 Scale Calibration Using Millimeters for Measurement

- SignMaster has a built-in resolution routine which can be used to easily perform this calibration:
 - ◇ Go to the **Vinyl Spooler** window and select the **Calibration** tab.
 - ◇ Click on the **Cutter Scale** icon:

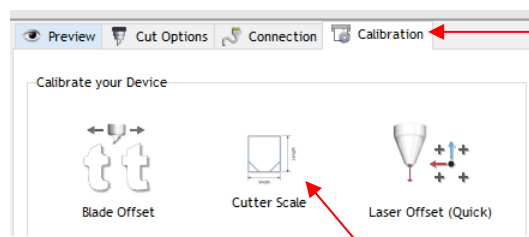

1. Select the **Calibration** tab

2. Click on the **Cutter Scale** icon

- ◇ A new window opens where you can enter the dimensions of a square or rectangle to draw with the test pen. It is highly recommended that the dimensions be at least 200 mm. Note that in the current version of SignMaster, the display in this window is always in inches. However, you can enter values in mm by typing in “mm” after the number as shown:

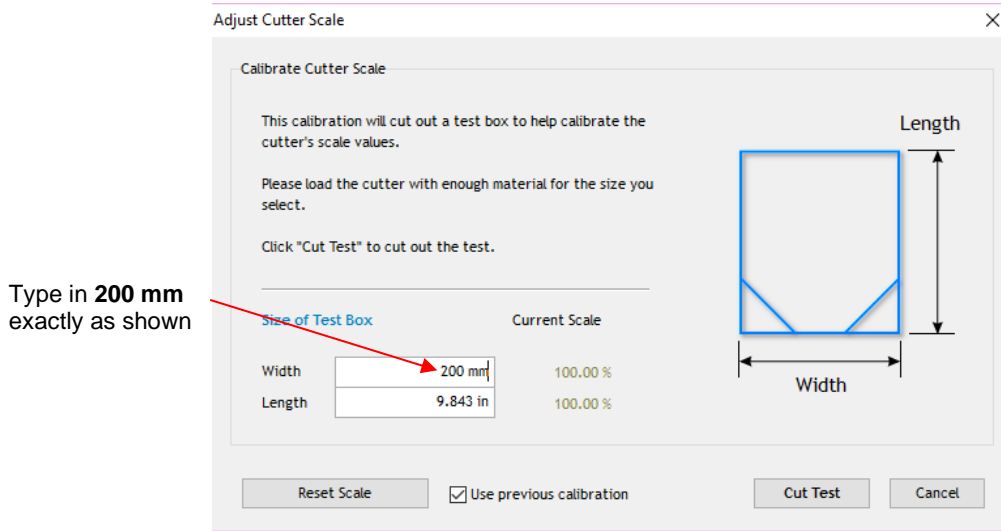

- ◇ Press the tab key and the 200 mm will be automatically converted into inches. Repeat with **Length**:

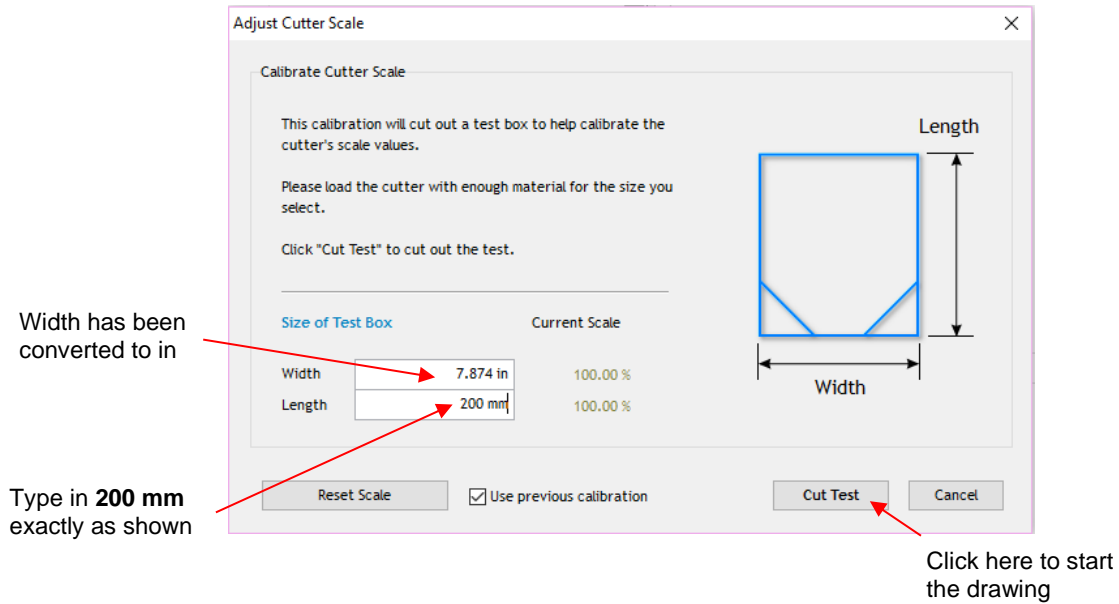

- ◇ On the Skycut, load a sheet of paper and insert the test pen. Move the test pen to the lower right corner of the paper. Make sure you have proper settings for drawing and click on **Cut Test** to have the shape drawn.
- ◇ Using a mm ruler, carefully measure the **Width** (left-to-right) and the **Length** (top-to-bottom) that drew:

Feed the mat this direction
into the Skycut

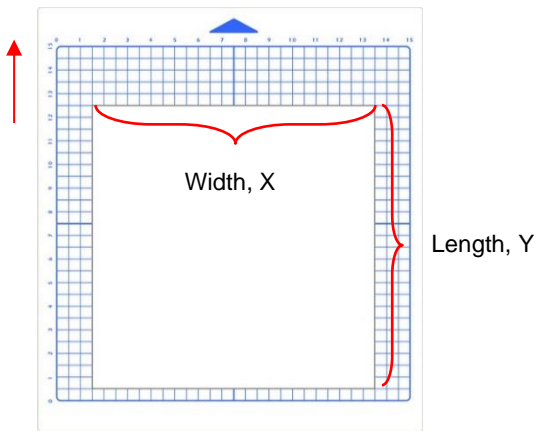

- ◇ Write these measurements onto your sheet:

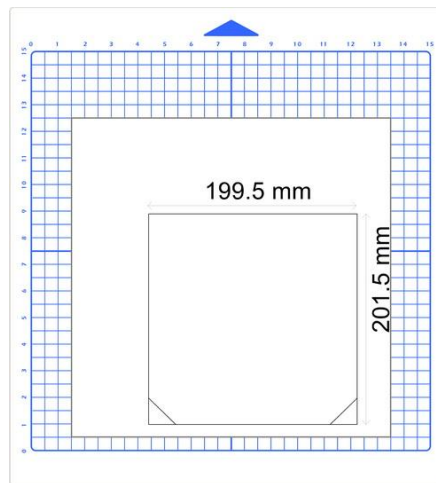

- ◇ These values can now be entered into the same **Width** and **Length** fields, again adding “mm” after each number as shown:

Calibrate Cutter Scale

After cutting the test box, you will need to accurately measure the Width and Length and enter these values in the area below.

Once you have entered the measured values, click "Update" to apply the scale calibration.

Size of Test Box Enter measured values here...

Width	<input type="text" value="199.5 mm"/>	100.25 %
Length	<input type="text" value="7.874 in"/>	100.00 %

Enter actual **Width** and add “mm”

Calibrate Cutter Scale

After cutting the test box, you will need to accurately measure the Width and Length and enter these values in the area below.

Once you have entered the measured values, click "Update" to apply the scale calibration.

Size of Test Box Enter measured values here...

Width	<input type="text" value="7.854 in"/>	100.25 %
Length	<input type="text" value="201.5 mm"/>	100.00 %

Enter actual **Length** and add “mm”

- ◇ After entering each number, the scaling percentage is automatically calculated:

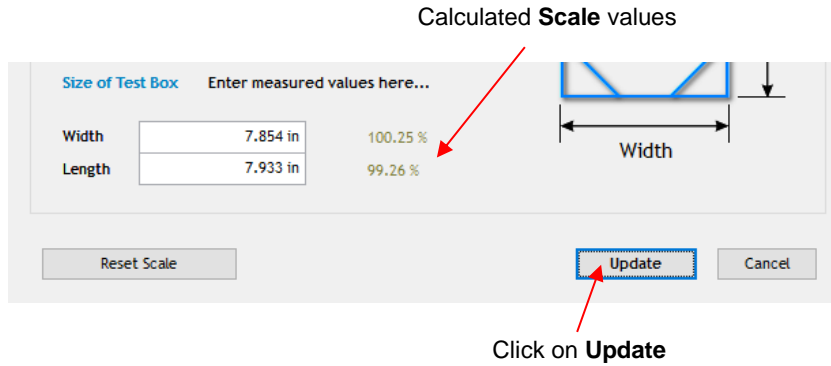

- ◇ Click on **Update** and a prompt window will ask if you want to **Apply Scale Adjustment**. Click on **Yes** and you'll be back in the **Vinyl Spooler** window. To verify the scaling, again click on **Cutter Scale** and repeat the same steps. Make sure you leave your new scale factors in place by having the following option marked:

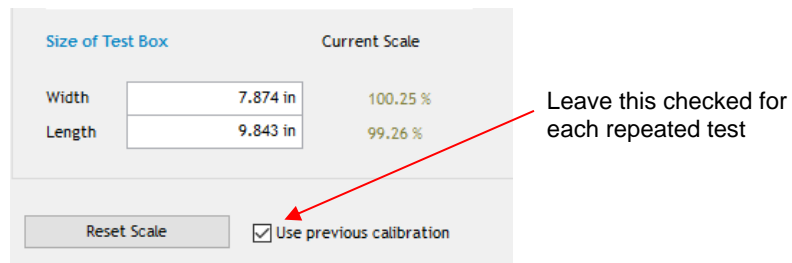

- ◇ Once your test rectangle is drawing at the correct size, the calibration process is complete.

2.08.2 Scale Calibration Using Inches for Measurement

- SignMaster has a built-in resolution routine which can be used to easily perform this calibration:
 - ◇ Go to the **Vinyl Spooler** window and select the **Calibration** tab. Click on the **Cutter Scale** icon:

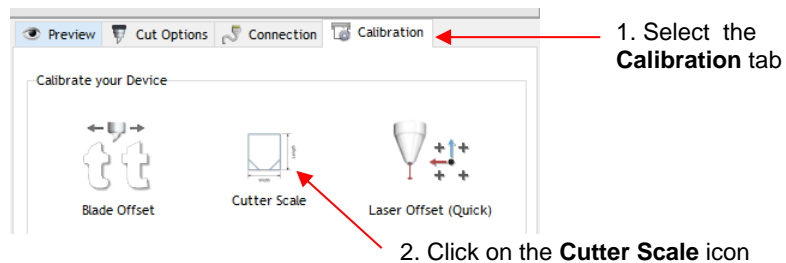

- ◇ A new window opens where you can enter the dimensions of a square or rectangle to draw with the test pen. It is highly recommended that the dimensions be at least 8 inches:

Enter **Width** and **Length** to use for test shape

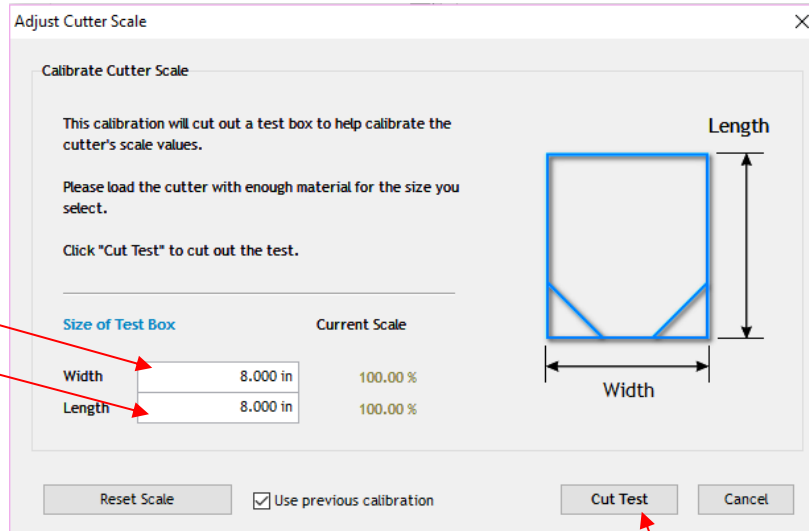

Click here to start the drawing

- ◇ Load a sheet of paper and insert the test pen. Move the test pen to the lower right corner of the paper. Make sure you have proper settings for drawing and click on **Cut Test** to have the shape drawn.
- ◇ Using a ruler, carefully measure the **Width** (left-to-right) and the **Height** (top-to-bottom) that drew:

Feed the mat this direction into the Skycut

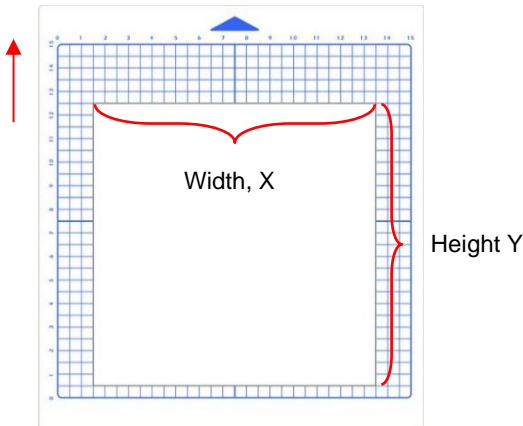

- ◇ Write these measurements onto your sheet:

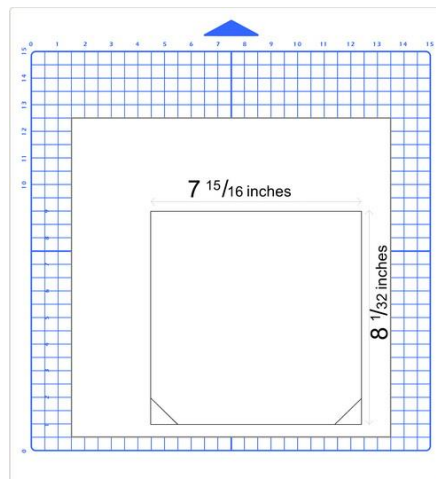

- ◇ Convert the measurements to decimals and enter these values into the same **Width** and **Length** fields. After entering each number, the scaling percentage is automatically calculated:

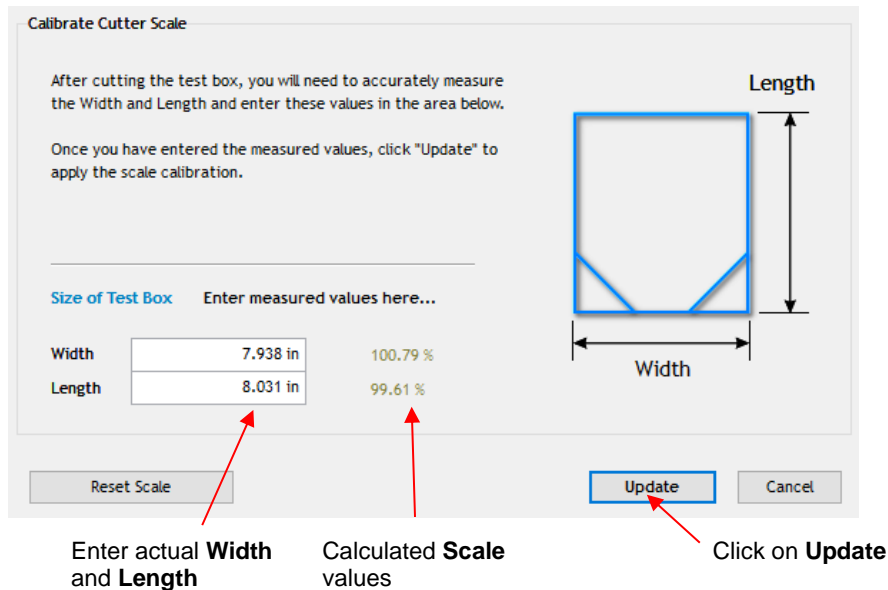

- ◇ Click on **Update** and a prompt window will ask if you want to **Apply Scale Adjustment**. Click on **Yes** and you'll be back in the **Vinyl Spooler** window. To verify the scaling, again click on **Cutter Scale** and repeat the same steps. Make sure you leave your new scale factors in place by having the following option marked:

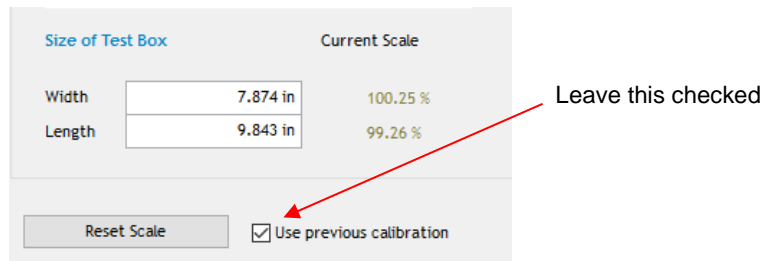

- ◇ Once your test rectangle is drawing at the correct size, the calibration process is complete.

2.09 Test Cutting Flow Chart for the Skycut

- Select a small test shape. You can use the built-in test on the Skycut. However, a shape with an internal path, such as a ring, works better as it allows you to more easily check to see if the blade is cutting into the backing sheet or cutting mat.
- Start with conservative **Force** and **Speed**.
- Insert the blade holder as instructed in *Section 2.01.3*.
- On the control panel: **Set>Advance Mode**, choose **to End** or **to Left** and enter a small distance, such as 0.5" or 10 mm to space each test.
- Set origin in the lower right corner of the material.

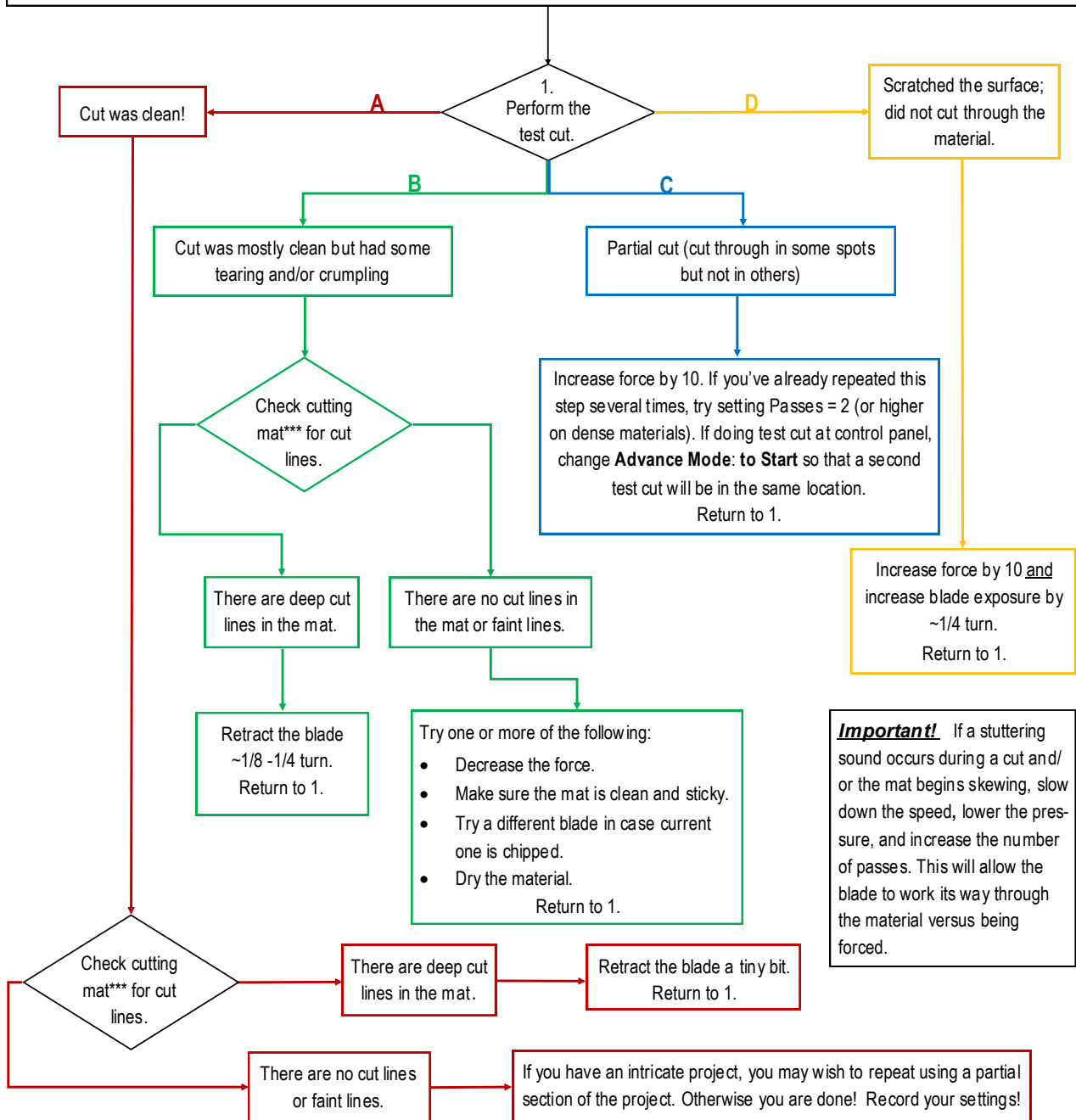

*** or backing sheet, such as with vinyl

2.10 Settings Form for Cutting Materials

<u>Material</u>	<u>Material Brand or Source</u>	<u>Blade</u>	<u>Force</u>	<u>Speed</u>	<u>Blade Offset</u>	<u># Passes</u>	<u>Other Comments</u>

2.11 Suggested Settings for Various Materials

IMPORTANT: These settings should be used for the initial test cut only. Adjustments may be necessary based on the condition of the blade, variations in the material, humidity, condition of the cutting mat, blade tip height, etc. Refer to *Section 2.09* for a guide to adjusting settings for optimizing the test cut.

Note: Speed settings are based on the number in parentheses in the **Cutter Control** tab.

Material Type	Material Brand/Source	Blade	Passes	Force	Speed	Other Comments
Cardstock: light	Light 65 lb (~176 gsm) Recollections	R	1	35	8	
Cardstock: medium	Medium: Textured Bazzill	R	1	40	8	Blade tip ht = 40 Post It notes
Cardstock: heavy	Accent Opaque 270 gsm (100 lb cover)	R	1	75	5	
Chipboard: cereal box	0.018" (0.4 mm)	B	1	50	5	Alt: 2 passes at 40
Chipboard	0.022" (0.5 mm)	B	2	75	5	
Chipboard	0.03" (0.76mm)	B	2	95	5	
Chipboard	0.06" (1.5mm)	B: left R: right	3: on both	75: on both	1: on both	Duplicated image- right side cut / half-blade exposure; left side cut at required blade exposure; Blade tip ht = 20 Post It notes
Clay	Use a clay press (or pastry machine) to make clay thin	B	1	11	10	Make sure pinch wheels will not cross over the clay. Blade holder mounted on top of black seat.
Copy Paper	Most any brand	R	1	30	8	
Fabric - Cork	embroiderygarden.com	B	2	40	5	Blade tip ht = 25 Post It notes; use an extra sticky mat and taped around edges. Brayered well.
Faux Leather	~ 1.2 mm thick from Art of Fabric Folding (on Etsy)	B	1	50	6	Extra sticky mat w/ material upside down. (mirror imagem, as needed)
Faux Leather	AOUXSEEM 1 mm (available on Amazon)	B	2	50	8	Extra sticky mat w/ material upside down. (mirror imagem, as needed)
Foam - Plain	2 mm	B	2	25	10	
Foam - Glitter	Foamy - 2 mm	R	2	15	10	
Magnet	Marietta Magnetics - 0.02" (0.5mm) (20 mil)	B	2	90	8	
Magnet	0.035" (0.9mm)	B	2	50	3	Alt: 1 pass at 85
Magnet	Marietta Magnetics - 0.02" (0.5mm) (20 mil)	B	2	90	8	

Material Type	Material Brand/Source	Blade	Passes	Force	Speed	Other Comments
Tracing Paper	Helix Vellum Paper	R	1	30	8	
Vinyl - Heat Transfer	Siser EasySubli - with the mat	R	1	30	8	Cut on the mat
Vinyl - Heat Transfer	Siser Glitter - Gold - No cutting mat	R	2	35-40	7	2 passes makes it easier to weed, also slight scratch cut in the backing layer
Vinyl - Heat Transfer	Siser Glitter - Gold - with the mat	R	2	45-50	7	2 passes makes it easier to weed, also slight scratch cut in the backing layer
Vinyl - Wall (no mat)	Vinyl - Oracal 631 - yellow	R	1	25	8	
Vinyl - Wall (on mat)	Vinyl - Oracal 631 - yellow	R	1	30	8	
Vinyl - Waterproof	Papilio	R	1	30	8	

© 2009- 2021 Sandy McCauley, All Rights Reserved

- The latest updates to these settings can be found [at this link](#).

3. Print and Cut (Contour Cut)

Video

3.00 Quick Reference for Chapter 3

- How to calibrate the camera: *Section 3.03 (V model), Section 4.01 (D model)*
- How to set up a contour cut: *Section 3.04*
- How to add more registration marks: *Section 3.08*
- Troubleshooting inaccurate print and cut results: *Section 3.06*
- How to set up repeats: *Section 3.07*
- How to do a PNC from a USB flash drive file: *Section 3.09.1*
- How to use the **Array Mark** function on the control panel: *Section 3.09.2*
- How to include a scoring layer in a print and cut project: *Section 4.03.2*

3.01 What Is a Print and Cut (PNC)?

- The print and cut process (also called PNC and contour cutting) involves printing an image from SignMaster to any printer you own and then, with the aid of the Skycut's camera, have the image or images cut out with perfect precision. Below are three typical kinds of print and cut applications but there can be other kinds.

- ◇ Cuts along the actual borders of the printed image(s):

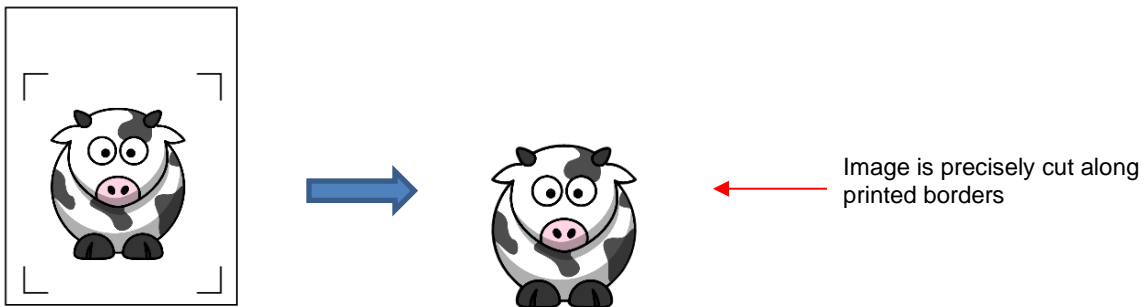

- ◇ Cuts outside of the borders but follows the shape(s) of the printed image(s):

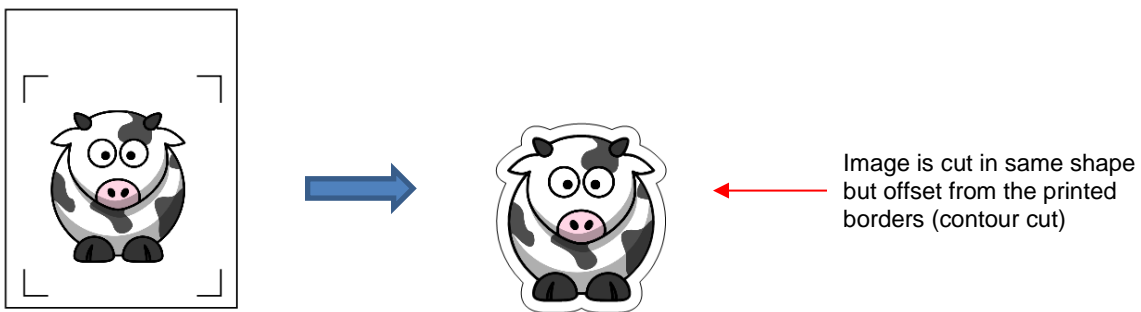

- ◇ Cuts follow a different shape from that of the printed image(s):

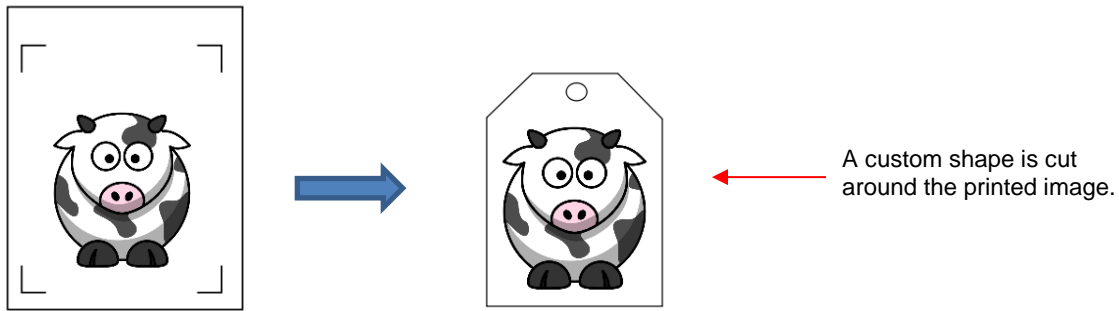

3.02 What is a PNC Calibration?

- In order to get precise PNC results, you must calibrate the camera. This is nothing more than letting the Skycut know how far away the camera lens is located relative to the tip of the blade. Because the camera is manually installed inside the blade carriage, the distance from the camera's center to the tip of the blade will vary from one Skycut to the next.
- This calibration only needs to be done one time. If you have travelled with your Skycut or it's been bumped fairly hard, you might want to run a test to make sure your calibration hasn't changed. It's also recommended that you check your calibration after any firmware updates are installed.
- The process, which is conducted through the control panel involves:
 - (1) Having the Skycut draw a test shape. At that point the camera takes a photo and displays it on the control panel, along with a red + and a large blue dashed +.
 - (2) Aligning the red + with the center of the test shape display several times until the blue dashed + is centered with the test shape.

3.03 Camera Calibration Procedure for Skycut V

IMPORTANT: Please use the following procedure for the Skycut V model. If you own a Skycut D, then calibrate the camera using the procedure presented in *Section 4.01* as it will calibrate the camera for both the left and right heads on the cutter at the same time. Then you can return to this chapter for more instructions on contour cutting applications which apply to both Skycut models.

- You need the following items for this calibration:
 - ◇ Sheet of paper
 - ◇ Test pen that came with your Skycut V
- (1) Insert the test pen into the Skycut. Place the sheet of paper into the Skycut. You can use the cutting mat to hold the paper or insert the paper directly.
- (2) Move the test pen over the sheet of paper. ***IMPORTANT:*** For all camera applications, make sure the starting origin is at least 3 inches from the right end cap so that the camera has room to move to the right to take a photo.
- (3) Select **Speed/Force** and set **SPEED** to ~ 8 and **FORCE** to ~ 30. Click on **Test** to verify that a square is clearly drawn. If it is too faint, increase **FORCE** as needed and repeat.
- (4) Move the pen an inch or two away from the test so that there is room for the calibration shape to be drawn.
- (5) On the **Main Screen**, press **Set** and then **Camera:**

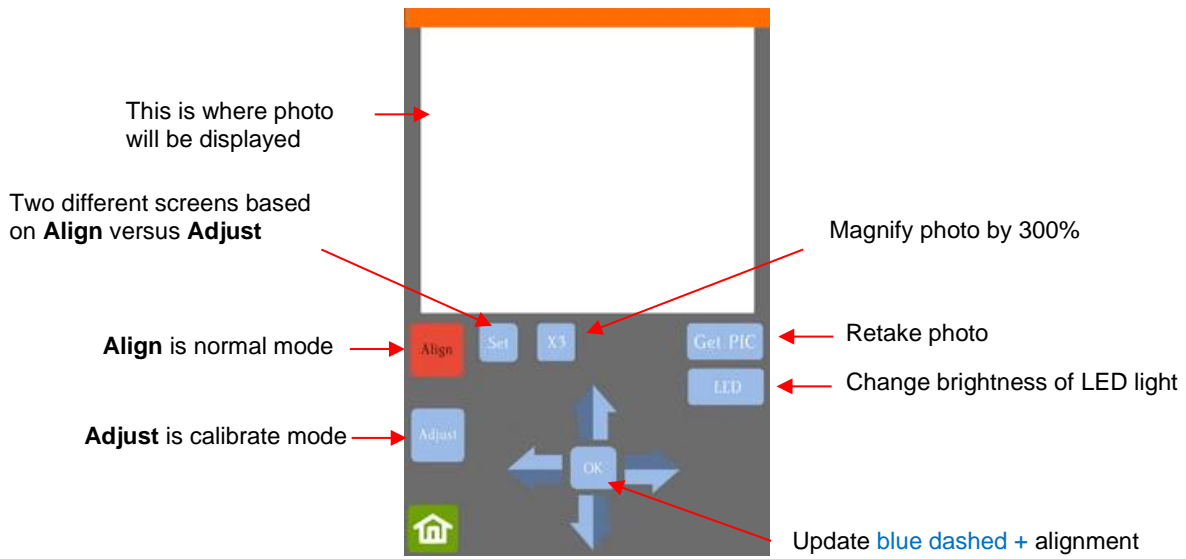

(6) Press **Adjust** to switch to calibrate mode. Press and hold the **OK** button for several seconds until it and the arrows around it turn red (if the buttons do not turn red, please refer to *Appendix B1*):

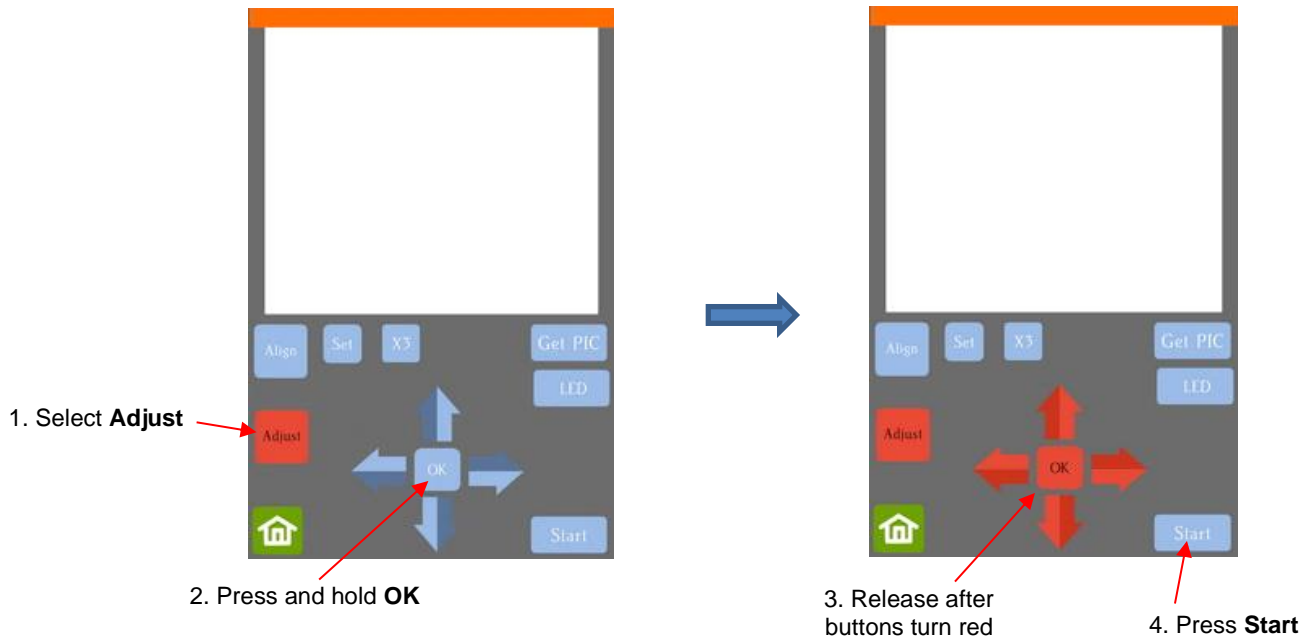

(7) Press **Start**. The test shape, which is a grid of 6 lines, will be drawn on the paper and the camera will move over the test shape, take a photo, and display the photo on the control panel. If you cannot see the test shape clearly, press the LED button once so that it reads LED 50% and press the **Get PIC** button. You should see three items in the photo: the test shape that was drawn with the pen, a **red +**, and the **blue dashed +**:

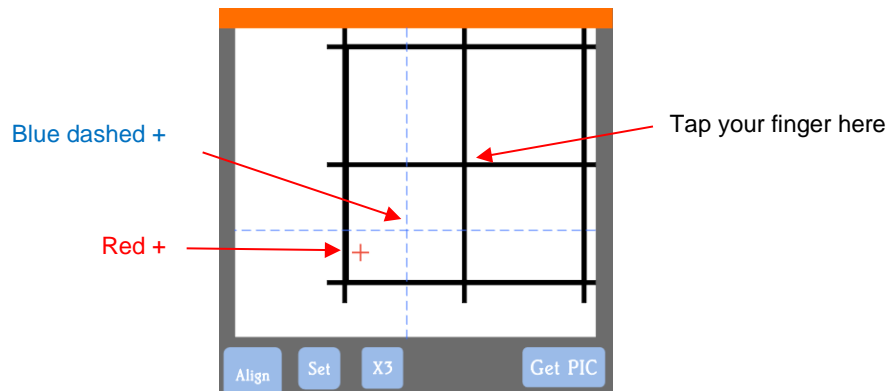

(8) Tap your finger near the middle of the drawn test shape. This will move the red + to that location:

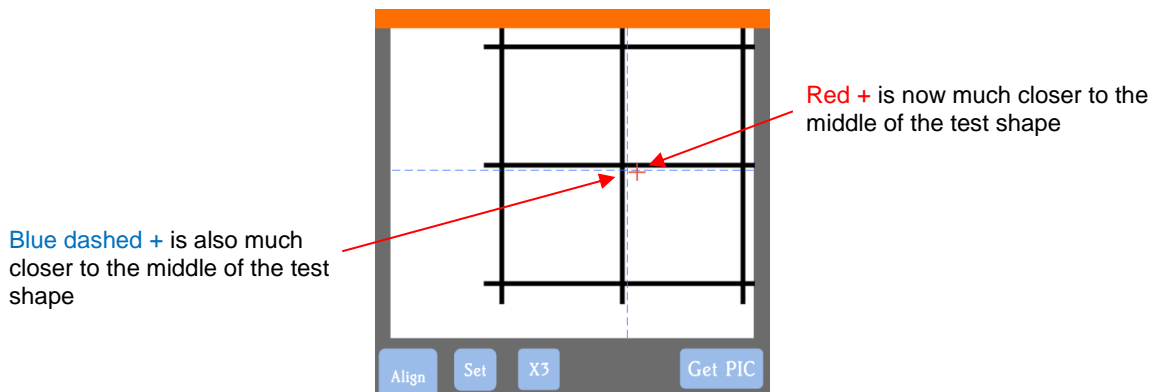

(9) Press **OK**. A new photo will be taken and one of two things will happen:

- ◇ Situation 1: The red + is so close to the center that the Skycut will now take over and find the true center on its own. You will see the red + and the blue dashed + aligned in the center and the arrows (only) will return to their blue color. Refer to the left side of the next screenshot.
- ◇ Situation 2: The red + and the blue dashed + are still not aligned and the arrows around the **OK** button are still red. Refer to the right side of the next screenshot. You will need to tap the center again and press **OK**. Continue, if needed, until the center is identified.

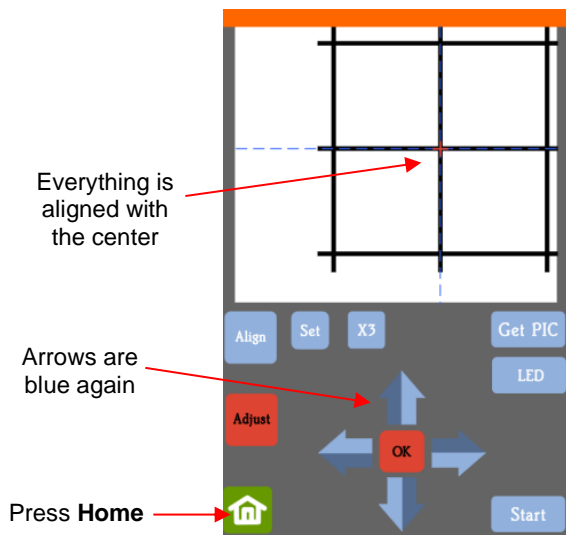

Situation 1

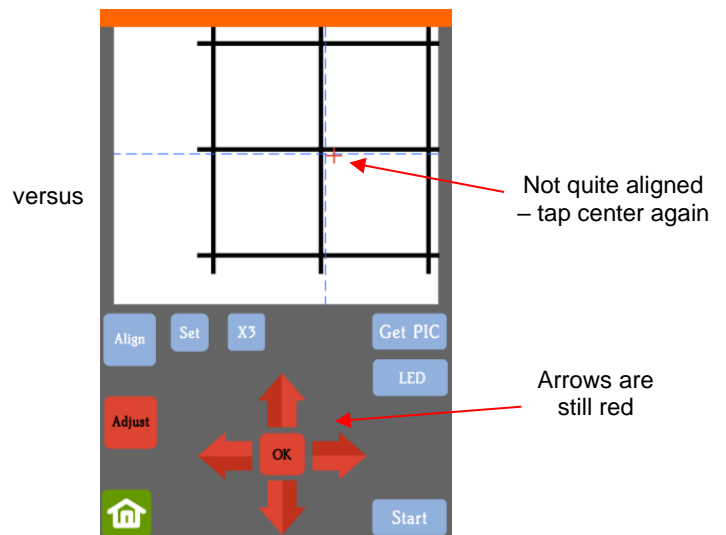

Situation 2

- (10) Once the alignment is in place and the arrows have turned blue, press the **Home** button and then press **Stop** on the **Main Screen** to save the calibration and conclude the process:

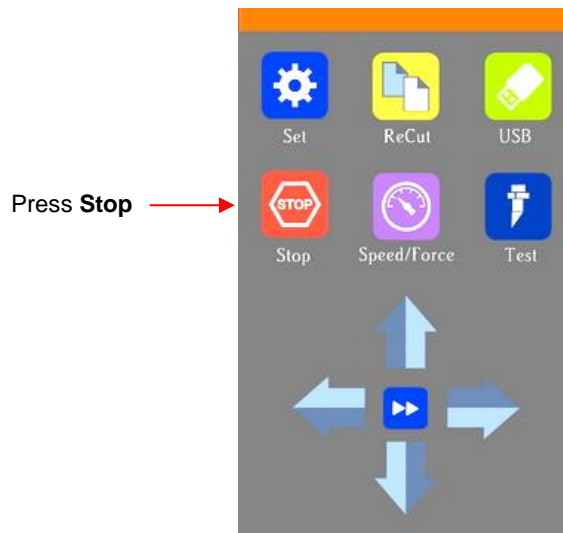

3.04 Performing a PNC in SignMaster

3.04.1 Summary of Steps

- Here are the typical steps when performing a PNC application:
 - ◇ Prepare the image(s) that will be printed which can include the following:
 - An imported raster image such as a JPG or PNG or BMP file
 - A vector image (either imported or designed in SignMaster) that will be printed but not cut
 - Text that will be printed but not cut
 - ◇ Prepare the cut lines which can include:
 - The resulting cut lines from tracing imported raster files. Refer to *Section 5.01* for details on using the **Trace** function in SignMaster.
 - A contour cut around the outside of the traced image: Refer to *Section 5.01*.
 - Any other vector shapes, either imported or designed in SignMaster: Refer to *Section 5.02*.
 - ◇ Print the project, after selecting reg mark properties, location of project on the page, and printer options.
 - ◇ Perform a test cut so that you know the best cut settings to use for the printed material. This test cut can often be performed on the printout itself if there is room in the waste area of the project.
 - ◇ Perform the cutting process.

3.04.2 Step-by-Step Simple PNC Project

- (1) While it's not a requirement, it can be helpful in designing if the **Drawing Area** dimensions match the printout size you plan to use. For this tutorial, **Letter** size (8.5" x 11") will be used. But you can use much larger sizes, if you have the ability to print in those dimensions.
- (2) To change the **Drawing Area**, click on the down arrow to open a drop-down menu with many page options or just enter the dimensions directly:

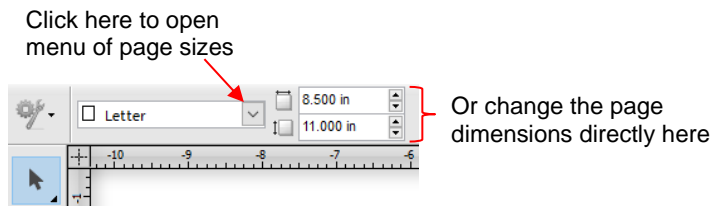

- (3) For a sample project, go to [this link](#) and download the zip. The project used in this tutorial is called *Yellow Ox PNC*. Alternatively, *Section 5.01* presents a tutorial on importing a graphic and adding a contour cut. Note the contour cut around this image:

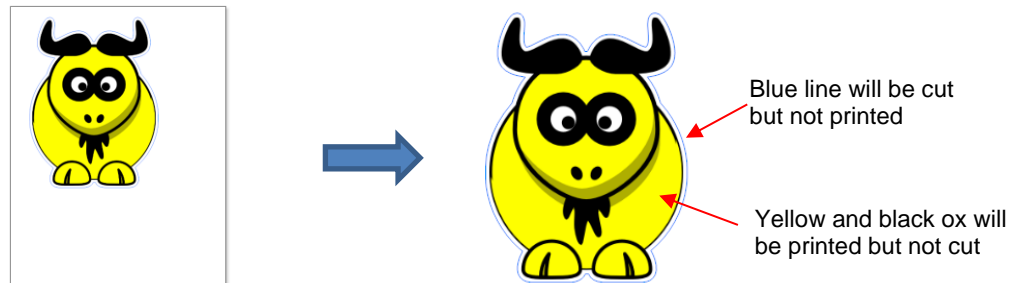

- (4) Click on the **Contour Cutting** icon  and select **Contour Cut Wizard**. The following window opens:

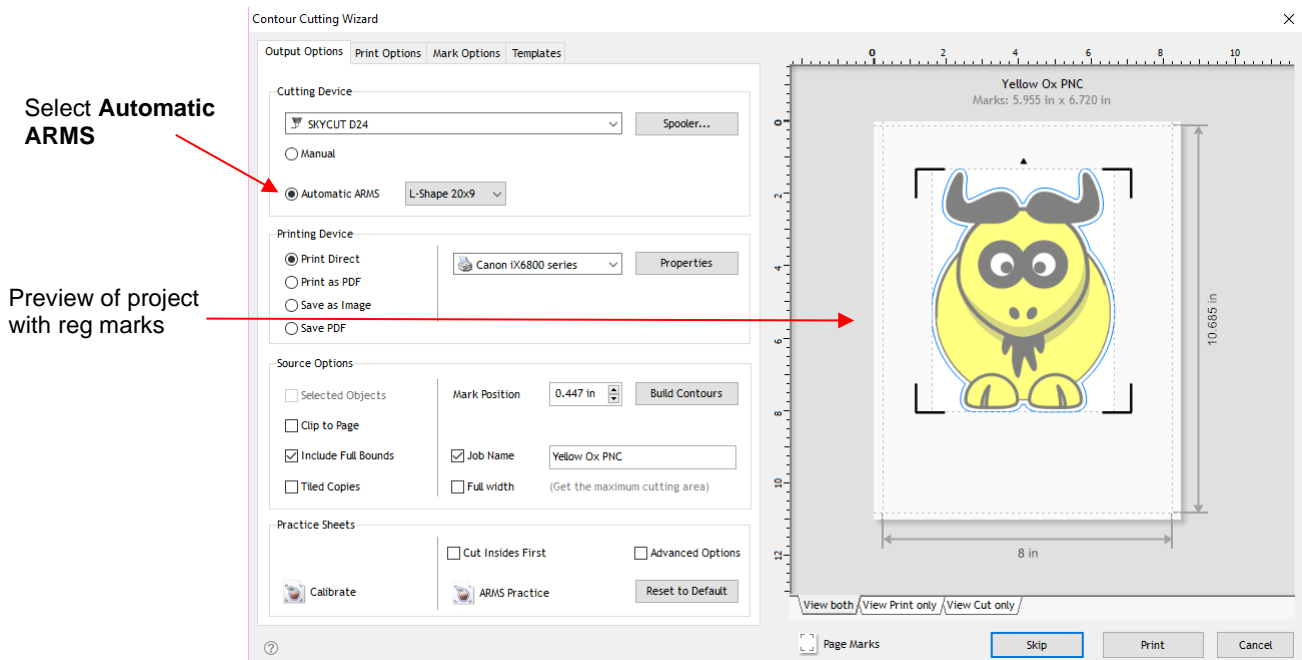

- (5) First, verify that **Automatic ARMS** is selected which means the camera will automatically scan the registration marks. Registration marks will appear around the image. Next, to verify “what will print” versus “what will cut”, click on the other tabs below the preview:

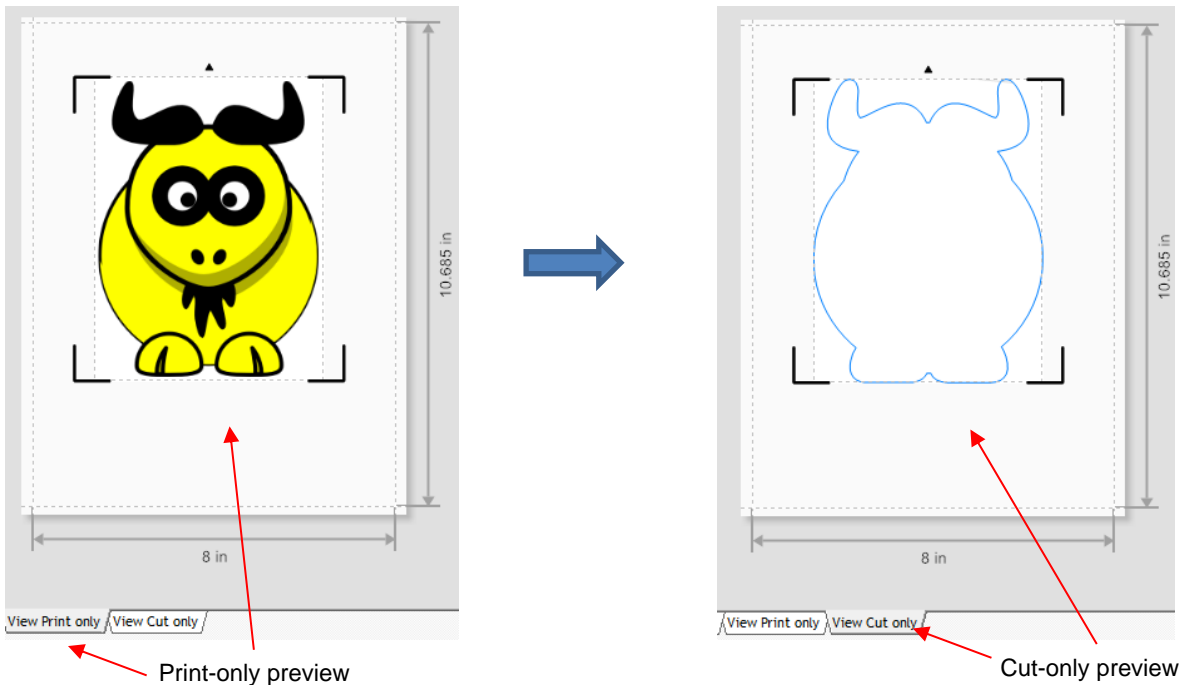

(6) The following options are available for printing:

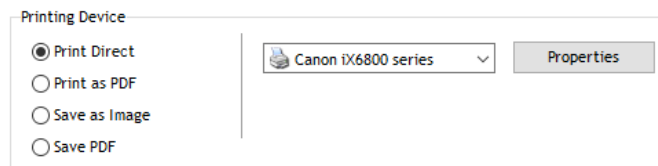

- ◇ **Print Direct** – Select this option if you are printing directly from this window to your own printer. Note that the printer menu and printer properties appear to the right when this option is selected.
- ◇ **Print as PDF** – Select this option to send the file to Adobe Reader to then print to your printer
- ◇ **Save as Image** – Select this option to export your printout as a JPG or TIFF file using the DPI resolution of your choice
- ◇ **Save PDF** – Select this option to export your printout as a PDF file to be saved and printed using a different computer/printer setup (such as taking to a professional printing company)

(7) Optional: Before printing, click on the **Print Options** tab and the project can be centered onto the printout by clicking the **Center** button:

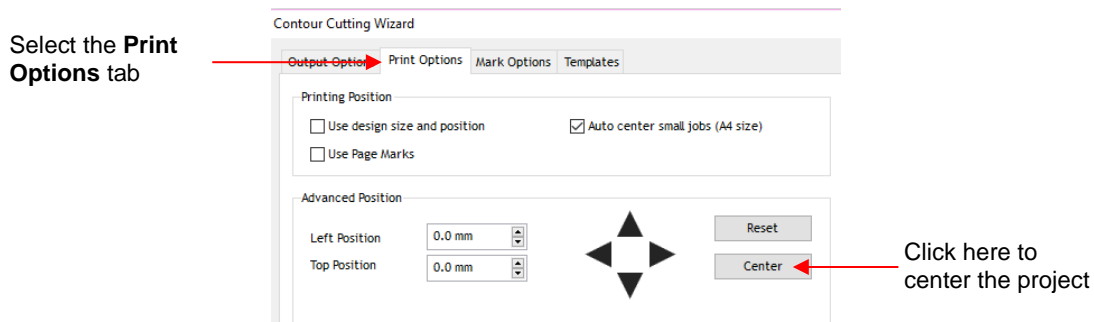

◇ The shape is moved to the center:

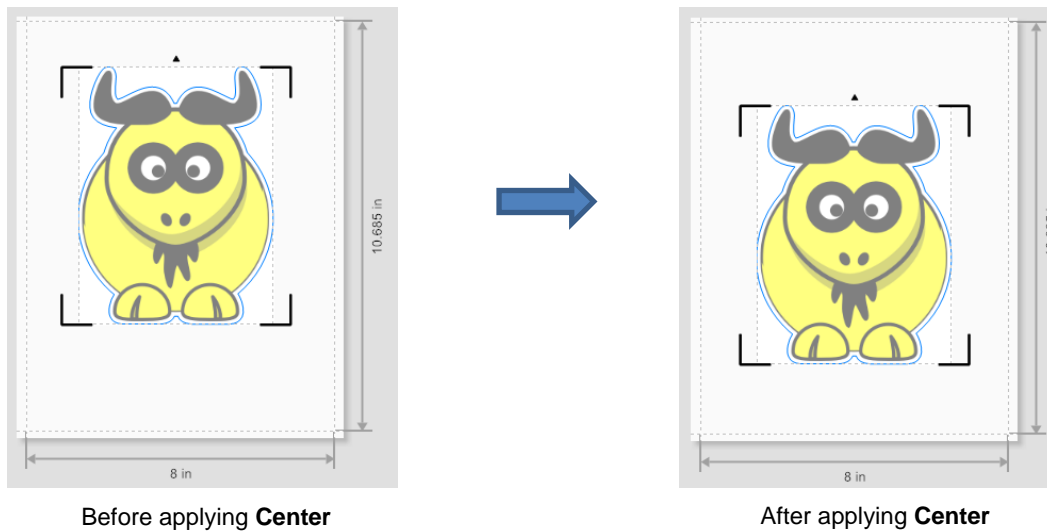

(8) Depending on the print option selected in *Step (6)*, the print button below the **Preview** will vary. Assuming you selected **Print Direct**, you'll see the option to **Print**. Click on it or click on the button in the same location and then complete any popup window options as needed. Note that if you've already printed your project, you will want to click on **Skip** instead:

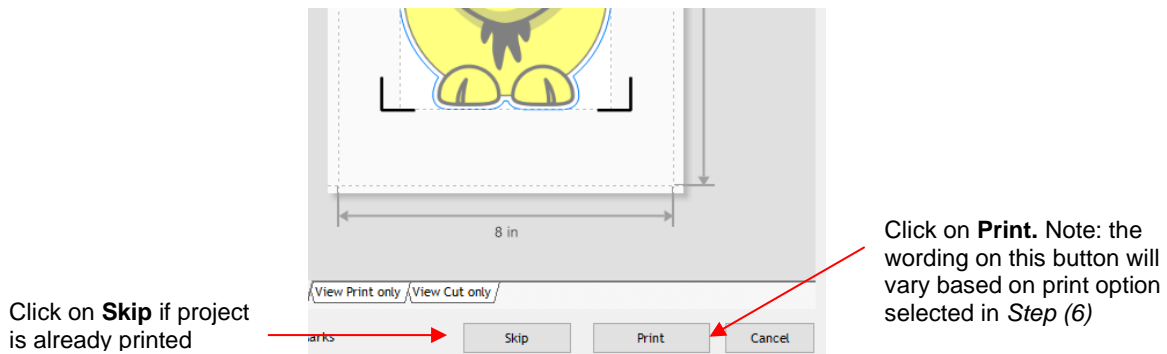

(9) Place the printout onto the cutting mat or load the printout directly if a cutting mat isn't required. Note that in SignMaster, a print and cut project is loaded "upside down" as shown in the following screenshot. On the printout is a small arrow which is a reminder to load the printout so that the little arrow is facing towards you as you are facing the Skycut:

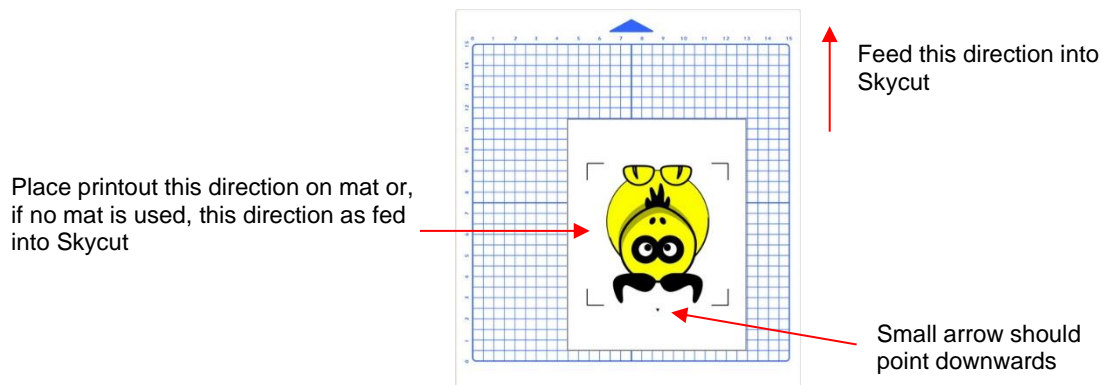

- (10) Load the mat and/or printout so that it is straight, relative to the cutter. The alignment doesn't need to be absolutely perfect but close enough that it will allow for a faster and, of course, successful detection by the camera. Insert the blade holder and perform a test cut, as needed, adjusting the cut settings.
- (11) Click on the **Spooler** and the **Cut Options** tab. If you want to send the cut settings from SignMaster, adjust the **Force** and **Speeds** accordingly or select a **Preset**. Otherwise, if using the cut settings on the Skycut control panel, turn these off. Click on **Done** after making any changes:

Click on **Spooler** to open the **Vinyl Spooler** window

Make any necessary changes in this window

Uncheck these options if settings on control panel will be used

Click on **Done** to close this window

- (12) Back in the **Contour Cutting Wizard** window, the **Print** button should now read **Cut Now**. Click on **Cut Now** and a new **Preview** window opens which indicates the design should be facing downwards:

Printout should be facing this way

Set blade holder over lower right reg mark

Click on **Next**

- (13) Click on **Next** and the Skycut's camera will now move over each registration mark and take a photo and make an adjustment. Once it has read all four marks plus the first one a second time, it will proceed to cut out the printed shapes.
- (14) After testing out this process, be sure to check out other sections to understand additional options, such as:
- ◇ Preparing a vector image for a PNC application – *Section 3.05.2*
 - ◇ Adjusting camera calibration settings, if needed – *Section 3.06.1*
 - ◇ How to set up a grid of repeats – *Section 3.07*
 - ◇ Adding additional registration marks to improve accuracy – *Section 3.08*
 - ◇ Performing a PNC using the USB flash drive – *Section 3.09.1*
 - ◇ Performing a dual head, score and cut PNC – *Section 4.03.2*

3.05 Preparing Designs for PNC Applications

3.05.1 Using Raster Images

- Use **File>Import>File** to open a raster image (JPG, BMP, TIFF, PNG, etc) in Signmaster. To add a contour cut around this image, there are two options:
 - ◇ Add the contour while in the main Signmaster window – this process is covered in *Section 5.01*.
 - ◇ Add the contour after entering the **Contour Cut Wizard** window by clicking on **Build Contours**:

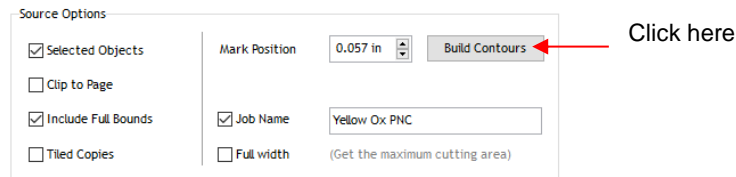

- Using **Build Contours** essentially takes you to the same **Create Cut–Contour** window and the process is the same as presented in *Section 5.01*.
- The advantage of tracing images before entering the **Contour Cut Wizard** window is the ability to edit the tracing and save the file with the tracing in place. An example of editing a trace is covered in *Section 5.01.2*.

3.05.2 Using Vector Images

- You can design your own vector images in SignMaster using various design and vectorizing tools. You can also directly import vector files in a variety of common file formats including: AI, DXF, EPS, PDF, PLT, and SVG.
- While vector images are essentially ready-to-cut files, SignMaster will not apply them as contour cuts in print and cut applications without having them assigned as such. Refer to *Section 5.02* for instructions on how to perform a contour cut using a vector image.

3.06 Inaccurate Cuts

- There are several reasons why your print and cut results may not be as accurate as you need:
 - ◇ The contours around the printed image are not accurate
 - ◇ The cut settings are too aggressive
- The following sections present solutions for each of these.

3.06.1 Inaccurate Tracings

- When tracing imported images, the resulting cut lines may not necessarily follow the original image, especially in tight spots. This can result in tiny bits of white appearing, suggesting the PNC wasn't accurate. Zoom in on the image so that you can see the trace line following the outline of the image. Compare by looking at the same spots where the cut didn't follow the image perfectly. This could be the cause of the inaccurate PNC. There are several ways of handling this situation:
 - ◇ Retrace the imported image using a lower **Smoothing** setting (refer to *Section 5.01*). This will result in a tighter fit around the original graphic.
 - ◇ Use the **Node Editing Tools**  to move the trace lines to more closely fit the original graphic.
 - ◇ Create an inset contour cut line to use for cutting instead of the original trace line.
 - ◇ Create a bleed by choosing **Cutting Contour + Bleed** in the **Create Cut Contour** window.
- Another possibility is that the contour cut line was inadvertently shifted from the graphic to be printed. So, check to see if a misalignment may have occurred when you were moving or simply clicking on the design.

3.06.2 Incorrect Cut Settings

- If a PNC is not precise and the cause is not the calibration nor the alignment of the trace lines, then go through the following check list of other possible causes:
 - ◇ Try slowing down the speed. If the mat is moving numerous times, in and out of the cutter, a slight shifting can occur, especially at high speeds. On the Skycut, try a speed of 7 or lower.
 - ◇ Verify that the pinch wheels are still centered over grit shafts beneath.
 - ◇ Make sure the blade isn't over-extended which can cause it to cut too deeply and drag the cutting mat.
 - ◇ Make sure the bottom of the mat isn't sticky and the pinch wheels and grit shafts are clean and not sticky. Clean with a lint-free cloth and a small amount of isopropyl alcohol or Un-Du.
 - ◇ If the print and cut project contains numerous repeats, use additional registration marks so that additional scans can occur during the cut. Refer to *Section 3.08* for instructions.

3.07 Adding Repeats in Print and Cut Applications

- (1) Create a design with the desired contour cut in place. In this tutorial, the same file is used as the one in *Section 3.04.2*, however the design has been resized to ~ 4.5" in height.
- (2) Click on the **Contour Cutting** icon  and select **Contour Cut Wizard**:

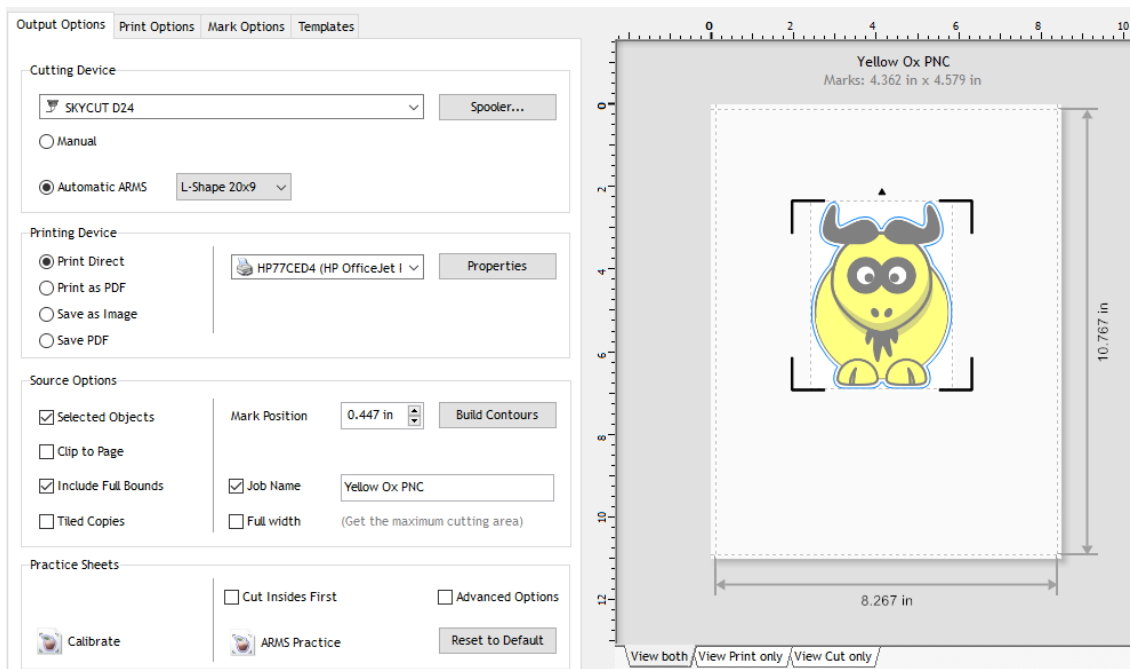

(3) To add repeats, click on the **Tiled Copies** option and the **Quantity** settings will appear below that:

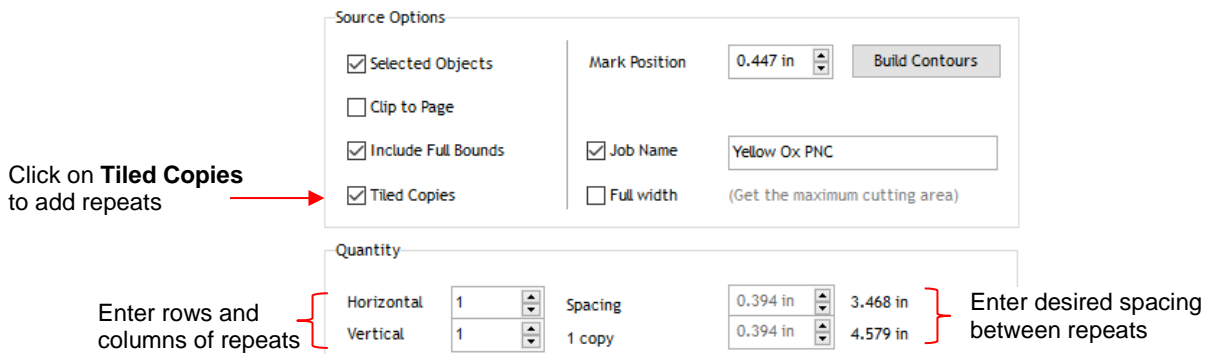

(4) As you enter repeats, the **Preview** will update showing the copies and the overall project dimensions. If you need to size the project for a particular printout's dimensions, mark the option for **Print Direct** so that you can verify whether or not the repeats will fit onto the printout. In this case, trying to fit 4 copies on a single Letter-size page will not work:

Select **Print Direct**

4 copies selected

Red margins and dimensions indicate project will not print with this number of copies

(5) In this case, either the spacing needs to be lowered or only two shapes can be used. So, the **Spacing** is decreased and the red margins and dimensions are now black:

Spacing reduced to 0.144 in

Black margins and dimensions indicate project will print

(6) Note that you have two options that can also be used, at times, to permit more copies to be printed:

- ◇ Reduce the **Mark Position** setting, which is how far the registration marks are located from the printed shapes. More about this option and the **Mark Options** tab are covered in *Section 3.08*.
- ◇ Reduce the size of the original by returning to the main window. This, of course, will work in some cases but not others.

3.08 Registration Mark Settings

3.08.1 Adding Intermediate Registration Marks

- Continuing with the same project from the prior section, to access the registration mark options, click on the **Mark Options** tab in the **Contour Cutting Wizard** window and note the following:

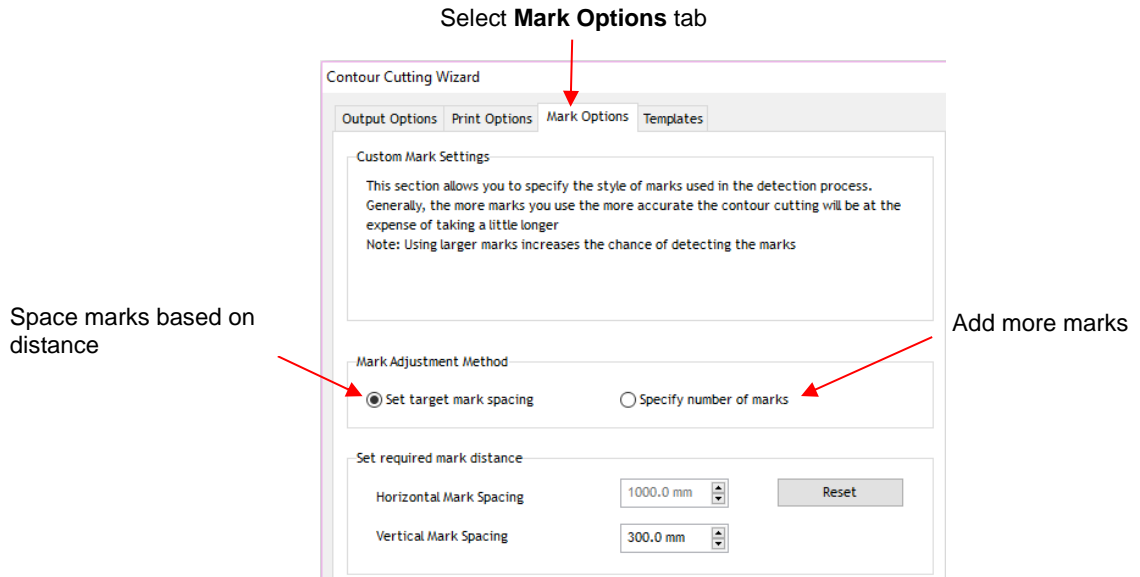

- ◇ **Set target mark spacing:** use this option as a default or if you want to reduce the maximum spacing allowed between marks, thus increasing the number of marks. For example, if **Vertical Mark Spacing** is lowered to 100 mm, in this particular case, a new set of intermediary marks are added:

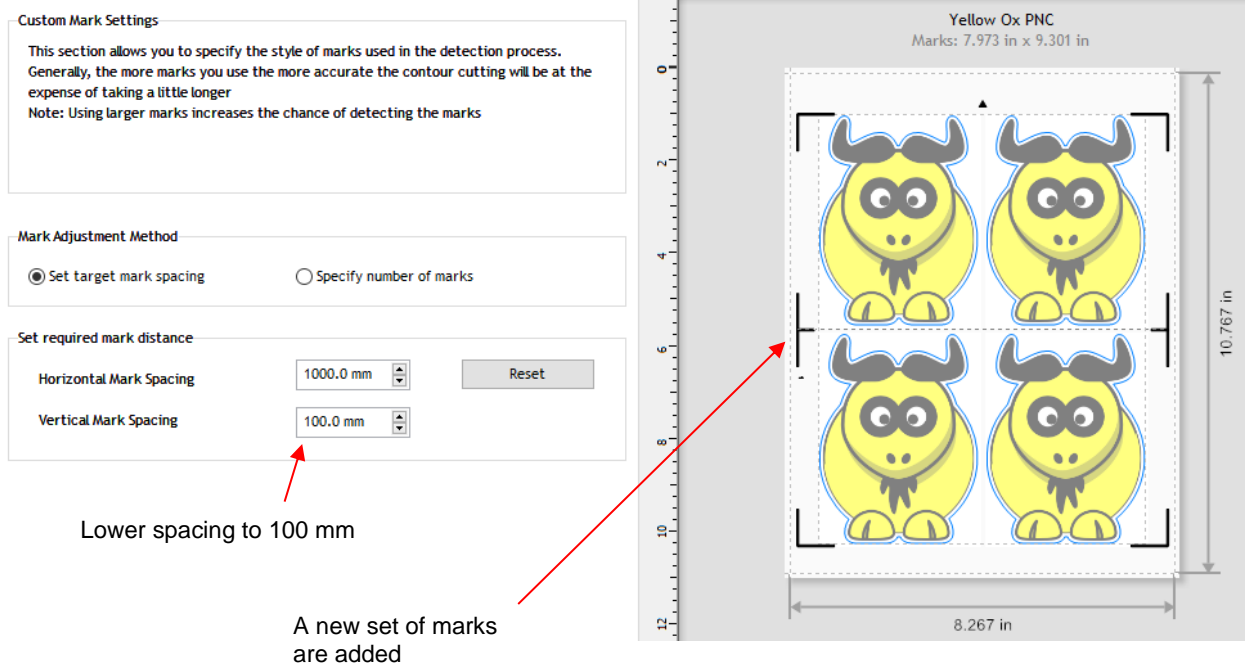

- ◇ **Specify number of marks:** use this option to force another set of marks to be added:

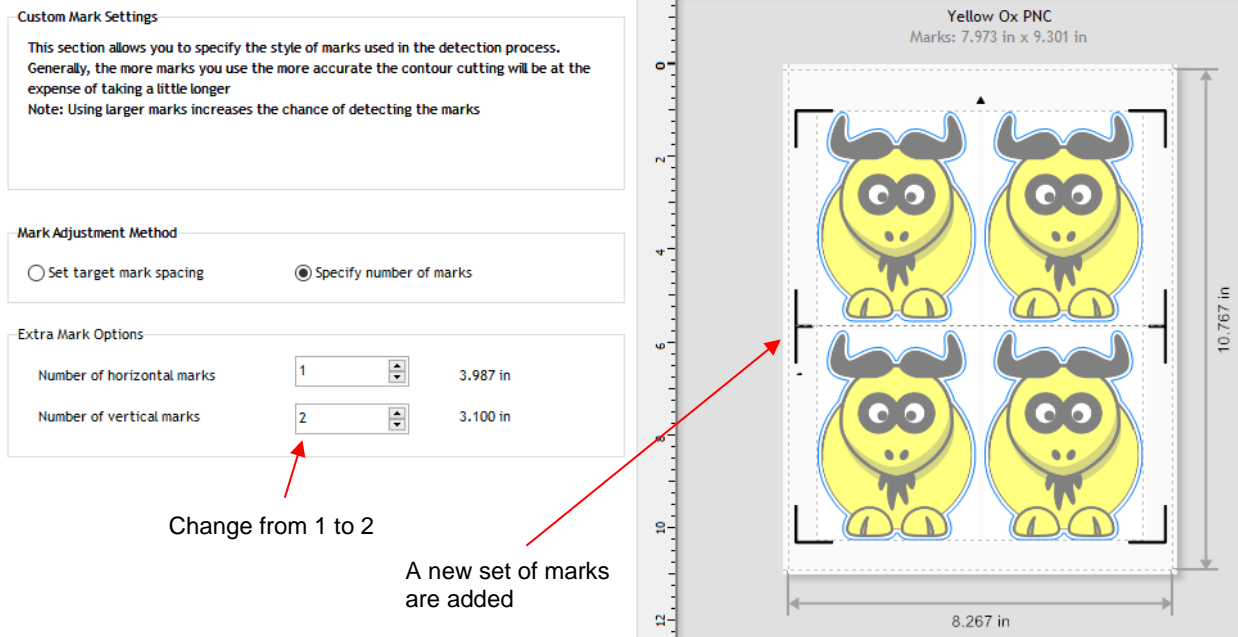

- With these intermediate marks added, they will be scanned, as well. Thus, in this example shown, the bottom four marks will be scanned and the lower two shapes cut out. Then, the top set of four marks will be read and upper two shapes cut out.
- Note that you can also add intermediate registration marks from the **Output Options** tab. This is presented in the following *Section 3.08.2*.
- **IMPORTANT:** Using the **Array plus Array Mark** options on the Skycut's control panel allows for more flexibility when working with multiple registration marks, such as being able to only scan one mark when there are repeats. This is covered in *Section 3.09.2*.

3.08.2 Registration Mark Types and Sizes

- The dropdown menu next to **Automatic ARMS** contains 9 options for the type and size of registration marks that can be used:

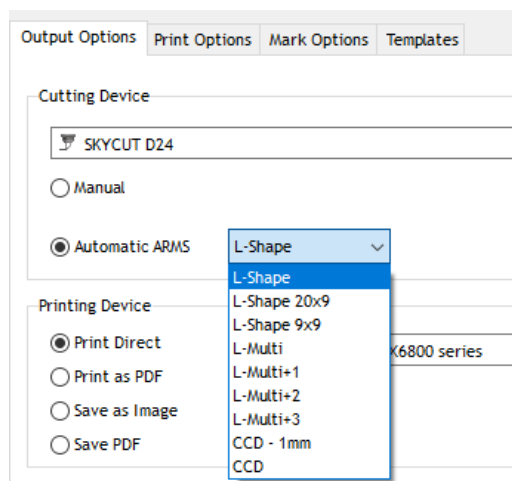

- There are two shapes available:
 - ◇ **L** - which is the right-angle type mark used in the screenshots so far in this chapter
 - ◇ **CCD** - circular dots



L registration marks

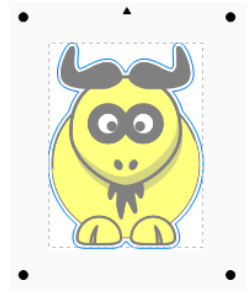

CCD registration marks

- Note the following size and applications for the individual options in the menu:

- ◇ **L-Shape:** L marks that are 20 mm x 20 mm in size

- ◇ **L-Shape 20x9:** L marks that are 20 mm x 20 mm in size. Any intermediate registration marks will be 20 mm x 9 mm in size:

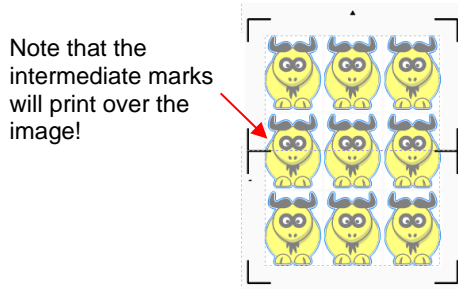

L-Shape

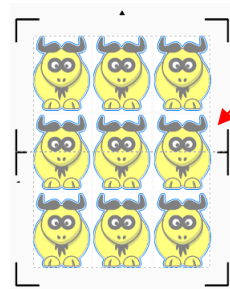

L-Shape 20x9

- ◇ **L-Shape 9x9:** L marks that are 9 mm x 9 mm in size

- ◇ **L-Multi:** Instead of using the **Mark Options** tab, intermediate registration marks can be added from the dropdown menu. This option will add one set of 20 mm x 9 mm intermediate marks.

- ◇ **L-Multi+1:** Same as **L-Multi**, but will add 2 sets of 20 mm & 9 mm marks

- ◇ **L-Multi+2:** Same as **L-Multi**, but will add 3 sets of 20 mm & 9 mm marks

- ◇ **L-Multi+3:** Same as **L-Multi**, but will add 4 sets of 20 mm & 9 mm marks

- ◇ **CCD – 1mm:** circular marks that are 1 mm in diameter

- ◇ **CCD:** circular marks that are 5 mm in diameter

3.08.3 Mark Position (Offset Distance from Design)

- You can also change the offset or distance of the marks from the image. However, you also need to make sure marks are not too close to anything printed so that the camera doesn't incorrectly attempt to scan the image instead of a registration mark:



Distance of the marks from the outermost shapes

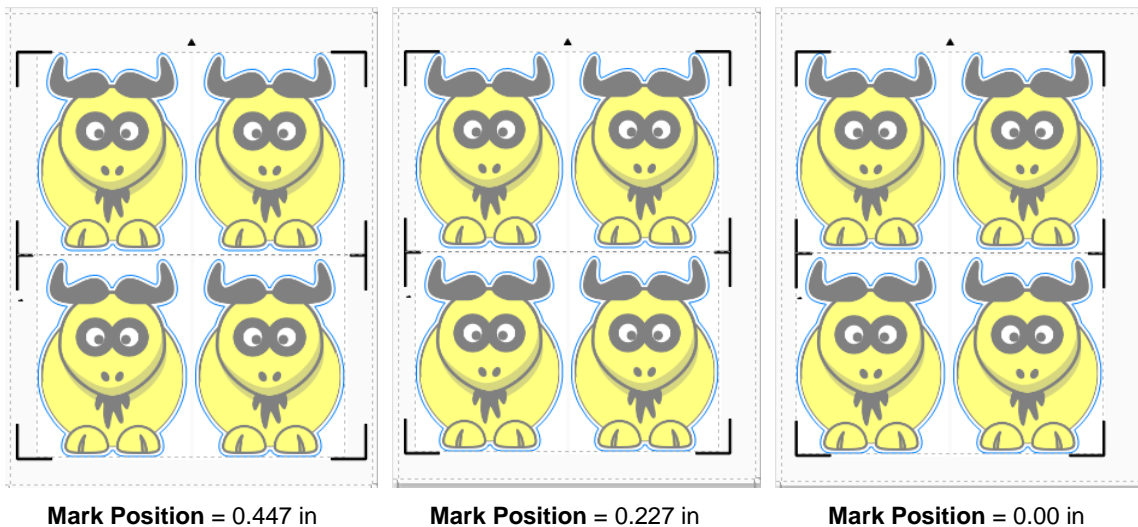

- You can see the movement of the marks towards the image as the **Mark Position** is decreased. Because of the shape of the ox, this shouldn't be an issue with the location of the registration marks relative to the printed image. However, if a design is more rectangular, such as a wine bottle label, then it is much easier to see that it could cause issues if the **Mark Position** is too small:

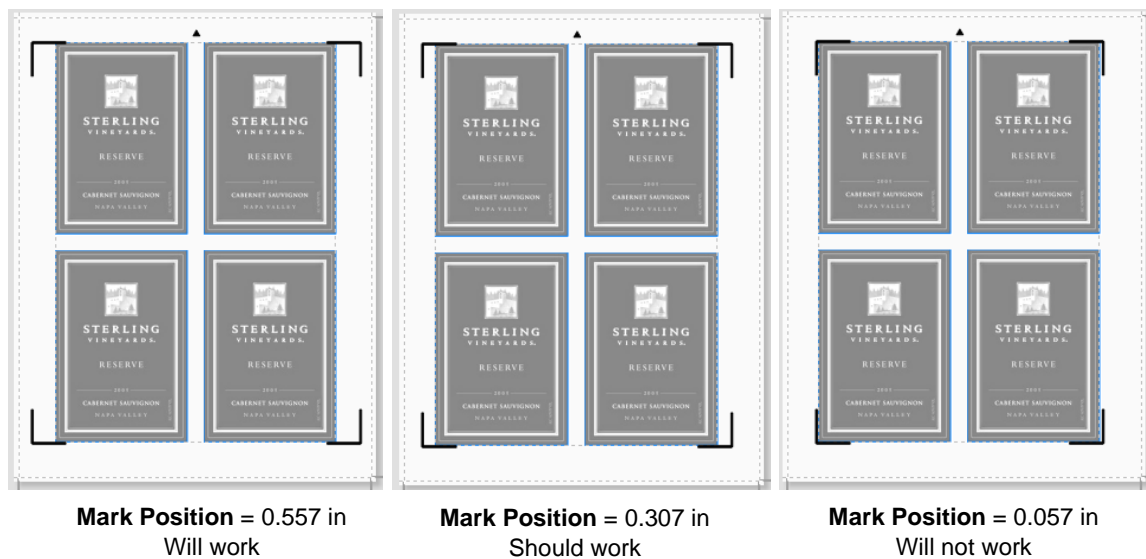

3.08.4 Page Marks Option

- Instead of setting a **Mark Position**, you can instead use **Page Marks** to place registration marks inset from the printout edges.
- Enable **Page Marks** below the **Preview** in the **Contour Cutting Wizard** window and the marks will move to the outer borders of the page area:

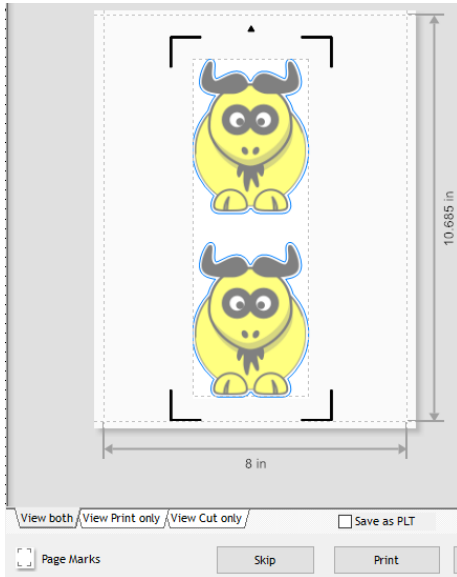

Mark Position option:
Reg marks are aligned with the project

versus

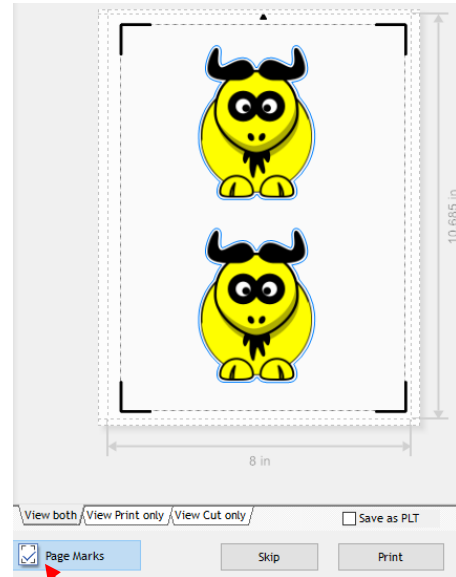

Page Marks option:
Reg marks are aligned with the printout edges

- To change the location of the **Page Marks**, click on the **Print Options** tab and under **Page Mark Options**, the distance from the page edges can be changed:

Contour Cutting Wizard

Output Options | **Print Options** | Mark Options | Templates

Printing Position

Use design size and position

Use Page Marks

Advanced Position

Left Position: 0.0 mm

Top Position: 0.0 mm

Reset

Center

Page Mark Margins

Left Margin: 15.0 mm

Top Margin: 10.0 mm

Right Margin: 10.0 mm

Bottom Margin: 10.0 mm

Change left and/or top distance from page edge

Change right and/or bottom distance from page edge

3.09 PNC from USB Flash Drive

3.09.1 PNC from Flash Drive – Single Cut

- To perform a print and cut project from the control panel, first perform *Steps (1) – (11)* from *Section 3.04.2*. However, before clicking on **Done** to close the **Vinyl Spooler** window, click on the **Connection** tab and change the **Port** to **U-Disk** from the drop-down menu. Then click on **Done**:

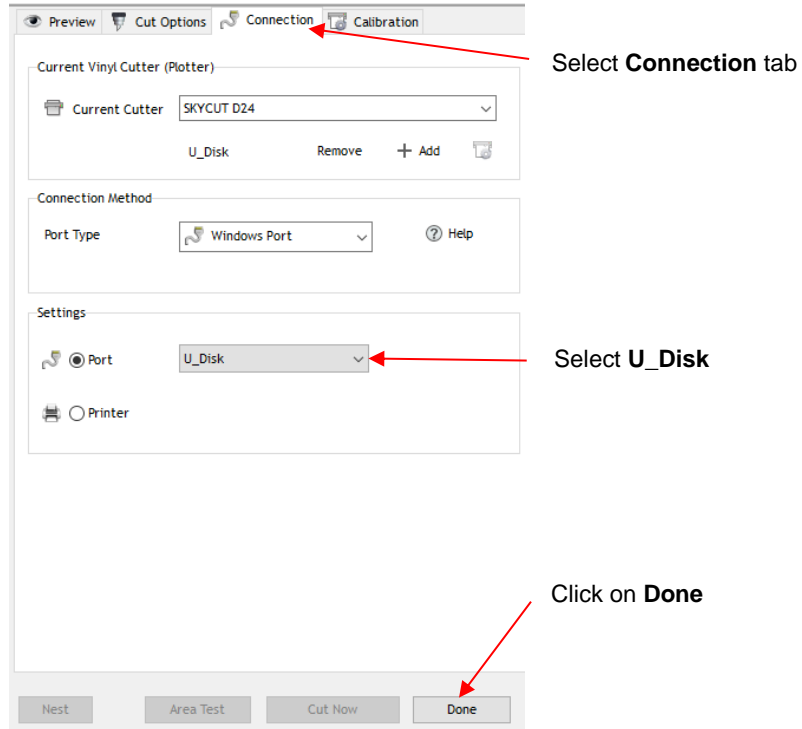

- Back in the **Contour Cutting Wizard** window, proceed as before by clicking on **Cut** and the same **Preview** window opens and again indicates the design should be facing downwards:

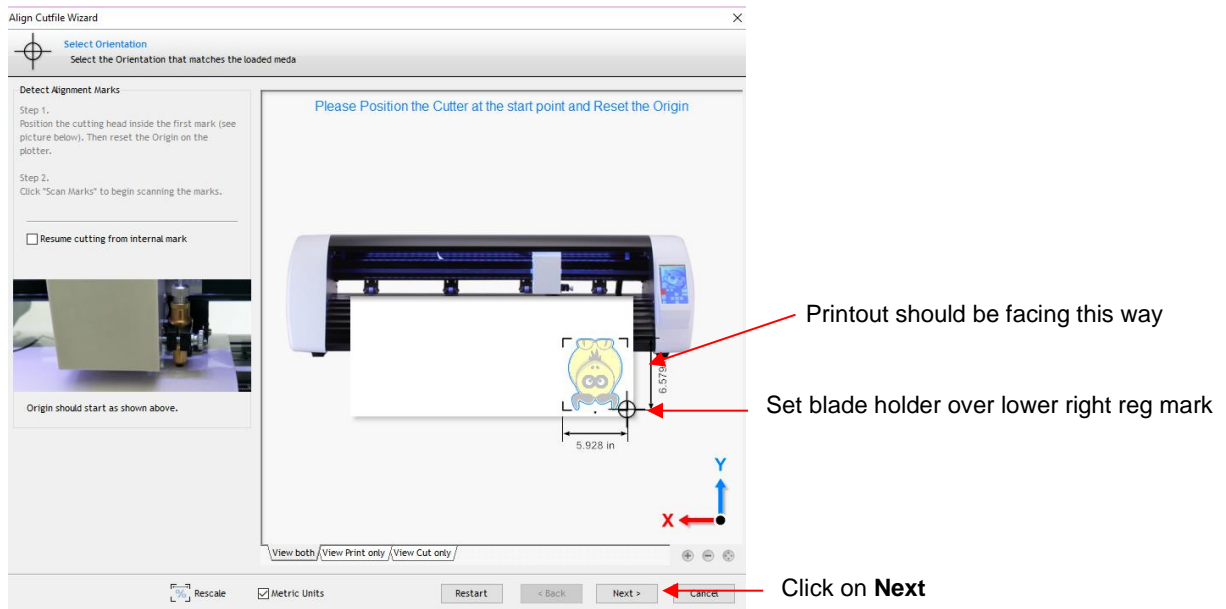

- Click on **Next** and the following window will open where you can save the job as a PLT file on a USB flash drive inserted into a port on your computer:

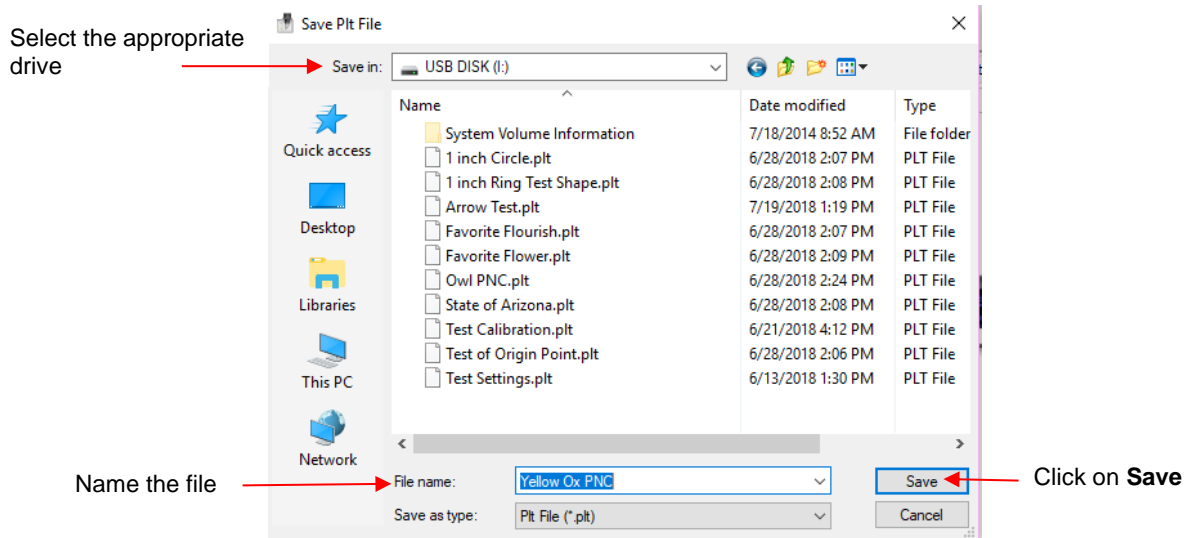

- On the Skycut's control panel, set the **Force** and **Speed**, if you elected not to have them activated in the **Vinyl Spooler** window in *Step 11* in *Section 3.04.2*.
- Go to **Set>Camera**. With **Align** selected, press **Set** and the following window will open:

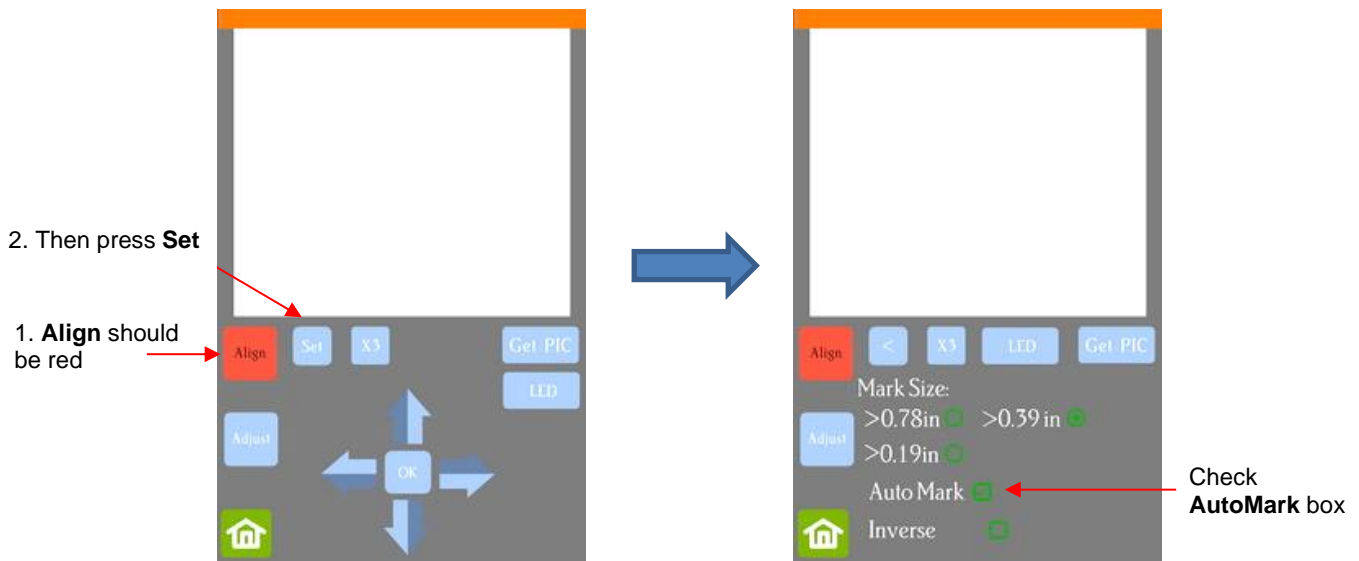

◇ Verify that **AutoMark** box is checked. Then click on **Home**.

- Insert the flash drive into the right side of the Skycut and use the instructions in *Section 1.12.3* to open the file into the Skycut:

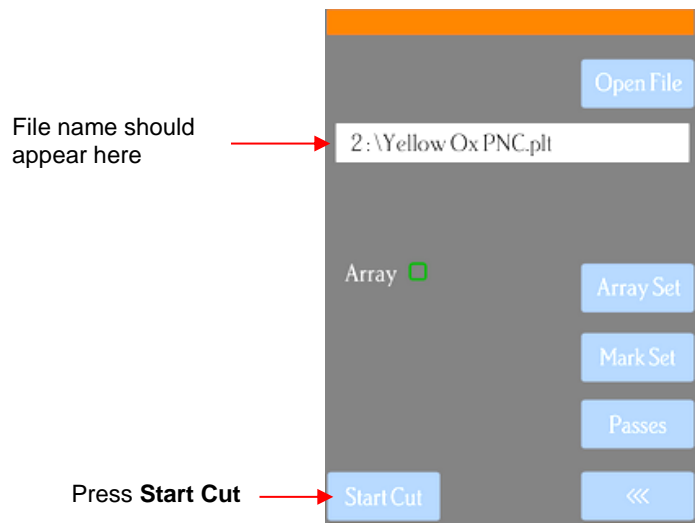

- Click on **Start Cut** and the marks will be scanned by the camera and the shapes cut out.

3.09.2 PNC from Flash Drive – Using Array Mark for Repeats

- The Skycut has the ability to set up an array of repeats for PNC applications. The advantage to using the Skycut’s control panel for this process is that the **Array Mark** function permits the scanning of additional registration marks as repeats are cut. This is far more accurate than only scanning the original four marks on significantly large projects:

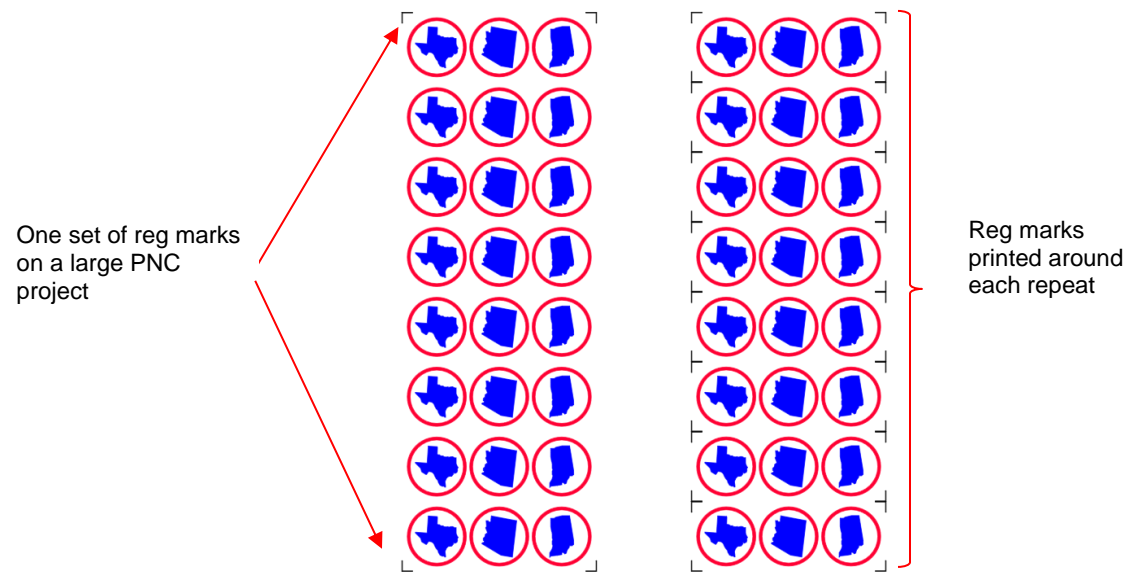

- The **Array Mark** window on the control panel can be opened in two ways:
 - Go to **Set>Advanced Settings>Array>Array mark**
 - Go to **USB>Array Set>Array mark**
- In the **Array Mark** window, you have three options:
 - **4 Mark:** Scan all four marks on every repeat

The number of marks	
4 Mark	✓
1 Mark	
Alternate	

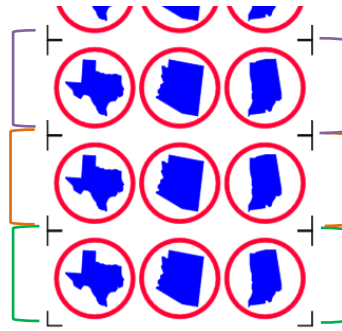

1. Four marks in **green set** are scanned first and first three shapes cut.
 2. Four marks in **orange set** scanned, next three shapes cut.
 3. Four marks in **purple set** scanned, next three shapes cut.
- etc.

- **1 Mark:** Scan first four marks on first set only. Then scan one mark only on each remaining repeat

The number of marks	
4 Mark	
1 Mark	✓
Alternate	

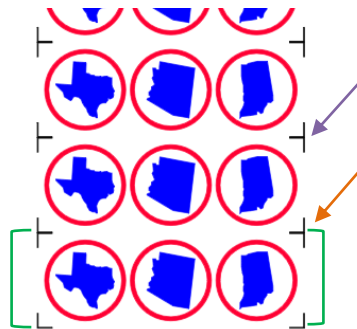

1. Four marks in **green set** are scanned first and first three shapes cut.
 2. Single mark by **orange arrow** scanned, next three shapes cut.
 3. Single mark by **purple arrow** scanned, next three shapes cut
- etc.

- **Alternate:**

Combination of **4 Mark** and **1 Mark** options

The number of marks	
4 Mark	
1 Mark	
Alternate	✓
changing interval:	
-	2
+	default

Alternate between scanning all 4 marks and scanning only 1 mark, based on a set **Interval**

Interval set to 1:

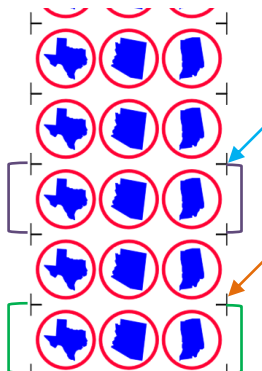

1. Marks in **green set** scanned and first three shapes cut.
 2. Single mark by the **orange arrow** scanned, next three shapes cut.
 3. Marks in **purple set** scanned, next three shapes cut.
 4. Single mark by **blue arrow** scanned, next three shapes cut.
- etc.

Interval set to 2:

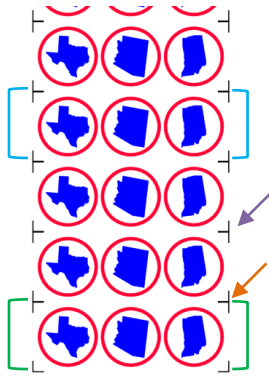

1. Marks in **green set** scanned and first three shapes cut.
 2. Single mark by **orange arrow** scanned, next three shapes cut.
 3. Single mark by **purple arrow** scanned, next three shapes cut.
 4. Marks in **blue set** scanned, next three shapes cut.
- etc.

- When choosing an **Array Mark** option, keep the following in mind:
 - The purpose of having intermediate scans is to correct for any slippage that occurs due to friction or excessively fast cutting speed.
 - Use **4 Mark** in situations where the repeats are quite large, thus there's a larger distance between the repeats and slippage is more likely to occur. It's also a good option when cutting thicker materials because the higher force applied by the blade can cause more drag on the material or cutting mat.
 - Use **1 Mark** in situations where the material is thin, the cuts are simple, and the distance between the repeats is relatively small. Obviously, this is the most time-efficient choice of the three options since a 4-mark scan is only performed one time.
 - Use **Alternate** as a compromise between the other two options. Experience will determine how high of an **Interval** can still yield the accuracy you need.

3.09.3 Mark Set Options

- The **Mark Set** window has the following two applications:
 - ◇ Select a specific range of images to cut versus the entire project file.
 - ◇ While the cutting is underway, if you observe that the accuracy is off, you can immediately pause the cutter and tweak the calibration for just that particular cut.
- To open the **Mark Set** window, press **Mark Set** on the **USB** screen:

NOTE: If your screen does not have **Mark Set** displayed, please go to *Appendix C* for activation instructions.

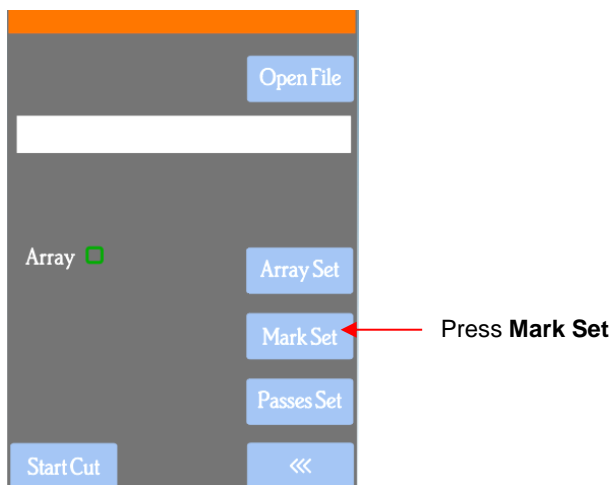

- To select a specific range of images, note the following:
 - ◇ The first set to cut is referred to as **M0** and then subsequent sets are **M1**, **M3**, **M3**, etc.
 - ◇ In the **Mark Set** window, select **Custom** and then enter the start and ending sets. For example, if you want to start with the second set and end with the seventh, you would change to **M2** and **M7**:

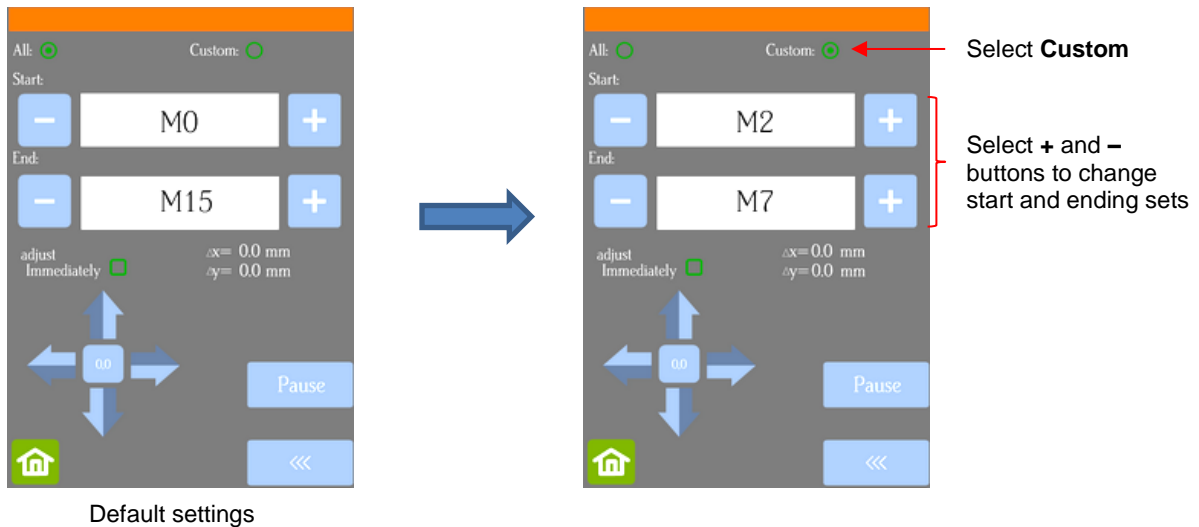

- ◇ The resulting sets will be sent versus the entire project:

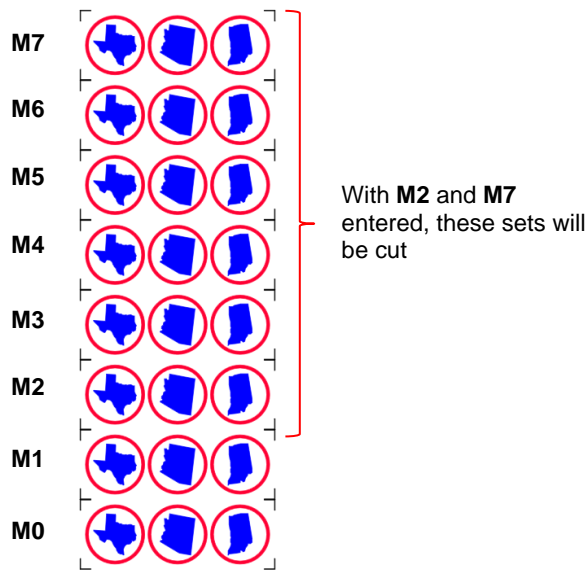

- To tweak the calibration after a cut has begun:
 - ◇ Press the **Pause** button on the **Home** screen to immediately stop the cutting.
 - ◇ Press the **USB** button on the **Home** screen.
 - ◇ Press the **Mark Set** button.
 - ◇ Check or uncheck the **adjust Immediately** option based on the following:
 - Check the option if you want the adjustment to be made on the current shape that was being cut when you paused the Skycut. Note that the start and end point on that path will not completely close, as a result.
 - Do not check the option if you want the adjustment to be applied on the next shape that will be cut.

- ◇ Click on the arrow buttons to adjust the Δx and Δy by the amount and in the direction you need the cut line to move:

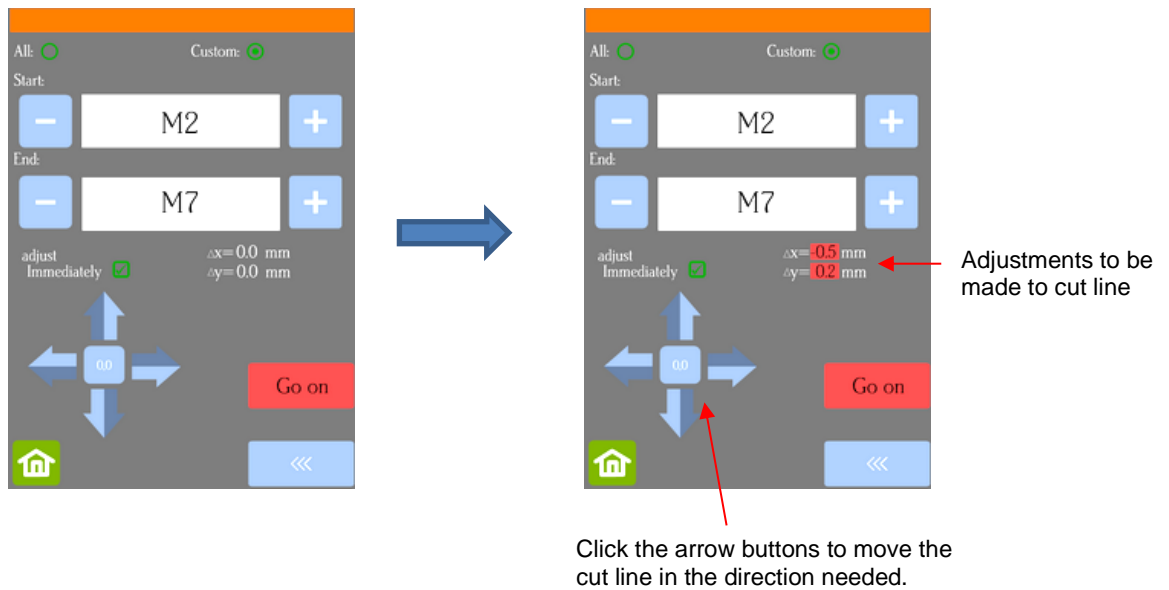

- ◇ Once you have entered the Δx and Δy values you wish to use, press the **Go on** button and the cutting will resume.

- **Important:**

- ◇ If you need to make yet another adjustment, repeat the process. The new Δx and Δy you enter is only an adjustment based on what you are now needing. For example, based on this example, if you need Y to move another 0.2 mm in the same direction, you would enter 0.2, not 0.4 mm.

4. Accessory Tools and Dual Head Calibration

4.00 Quick Reference for Chapter 4

IMPORTANT: Note that some of the tutorials in this chapter will be for the Skycut V model while others will be for the Skycut D model. The following list indicates which section should be used for one or the other.

- How to calibrate the camera on a Skycut D model: *Section 4.01*
- How to draw with the test pen and cut around the drawing: *Section 4.02.1 (D model) / Section 4.02.2 (V model)*
- How to score and cut a fold-up, print and cut (contour cut) project: *Section 4.03.2*
- How to emboss cardstock: *Section 4.03.3*
- How to engrave a metal tag: *Section 4.04.1*

4.01 Dual Head Camera Calibration

- In *Section 3.03*, the camera calibration was presented for the Skycut V. The following procedure shows how to calibrate the camera for the Skycut D so that both the left and the right heads are calibrated at the same time. This then allows you to do accurate draw-and-cut, score-and-cut, engrave-and-cut, and other combined tool applications.
 - You need the following items for this calibration:
 - ◇ Sheet of paper
 - ◇ The 2 test pens that came with your Skycut D
- (1) On the control panel's **Main Screen**, make sure the **Use Double Head** option is selected. If you do not see any of these options, click on **Set>Advanced settings>System mode** and select **double**. Then, back on the **Main Screen**, the options should now be available:

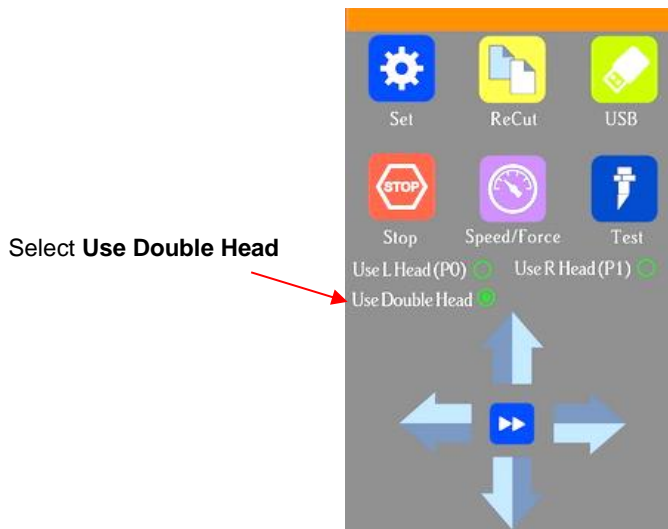

- (2) Insert a sheet of paper into the Skycut, either on the cutting mat or directly inserted. Load a test pen into both the left and right-side blade holder seats, making sure the pen nib is a tiny bit above the paper, as you did in *Section 1.13*. You can also use a stack of 35 Post It notes as presented in *Section 2.01.3*.
- (3) Select the **Speed/Force** function and make sure both sides are set to a suitable **Force** for drawing: ~ 30 – 40.

- (4) Make sure both pens are over the paper. ***IMPORTANT:*** For all camera applications, make sure the starting origin is at least 3 inches from the right end cap so that the camera has room to move to the right to take a photo.
- (5) On the **Main Screen**, select **Set>Camera** to open the camera calibration screen:

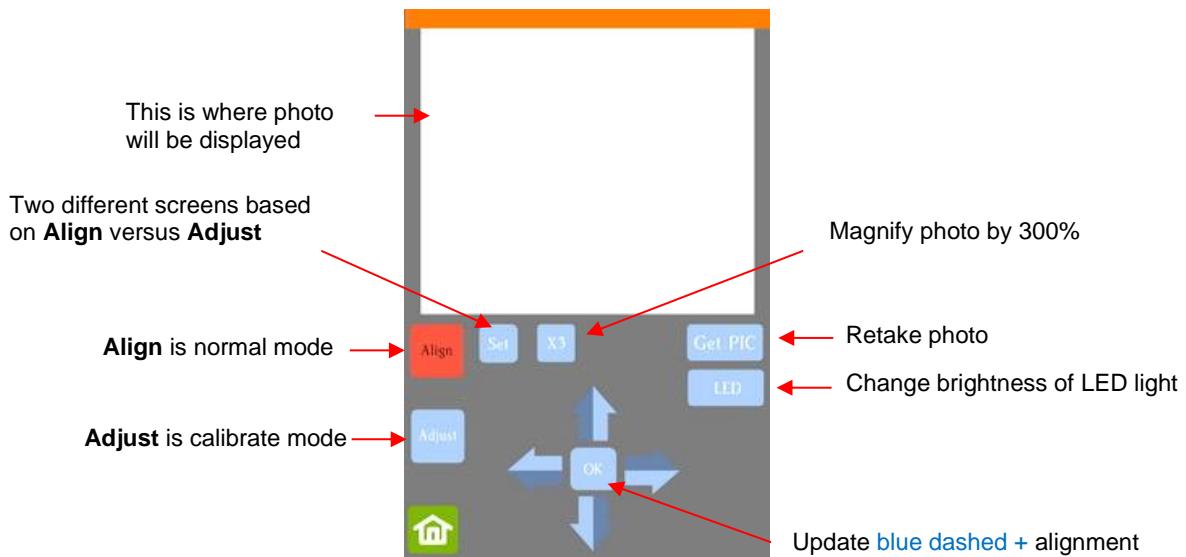

- (6) Press **Adjust** to switch to calibrate mode. Press and hold the **OK** button for several seconds until it and the arrows around it turn red (if the buttons do not turn red, please refer to *Appendix B3*):

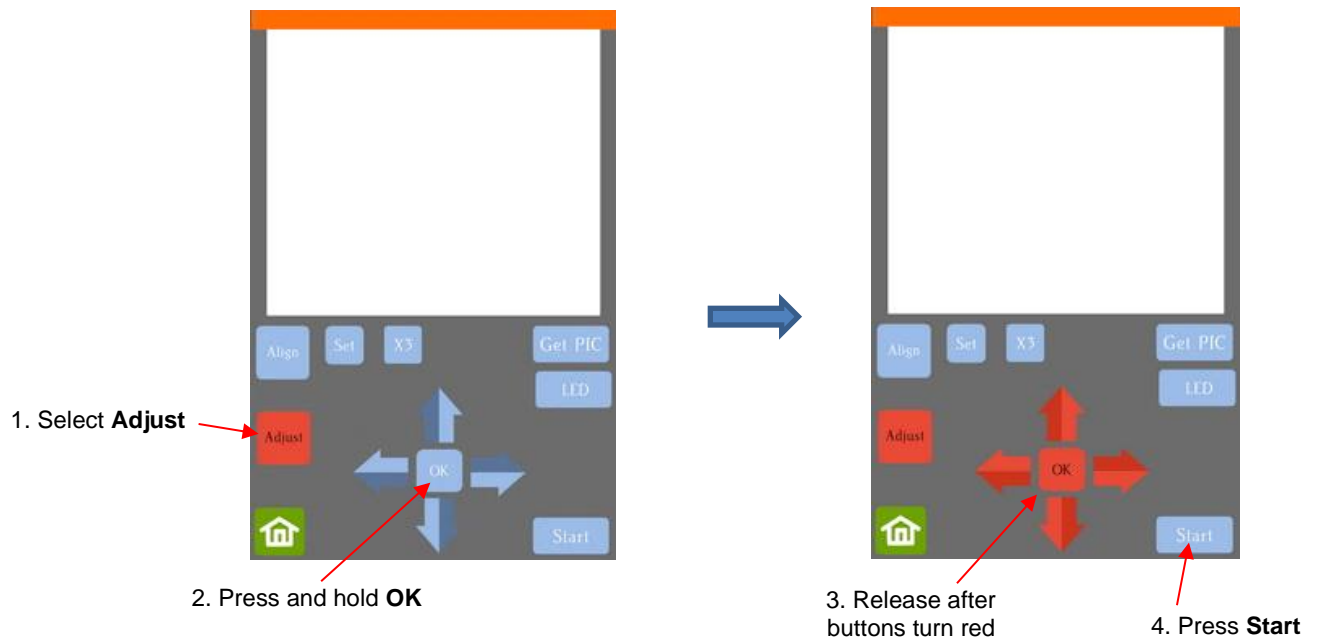

- (7) Press **Start**. The test shape, which is a grid of 6 lines, will be drawn first on the right side of the paper by the right-side pen. Then the same test shape will be drawn by the left-side pen about 4 inches to the left of the first test shape.
- (8) The camera will move over the right-side test shape, take a photo, and display the photo on the control panel. If you cannot see the test shape clearly, press the LED button once so that it reads LED 50% and press the **Get PIC** button. You should see three items in the photo: the test shape that was drawn with the right-side pen, a **red +**, and the **blue dashed +**:

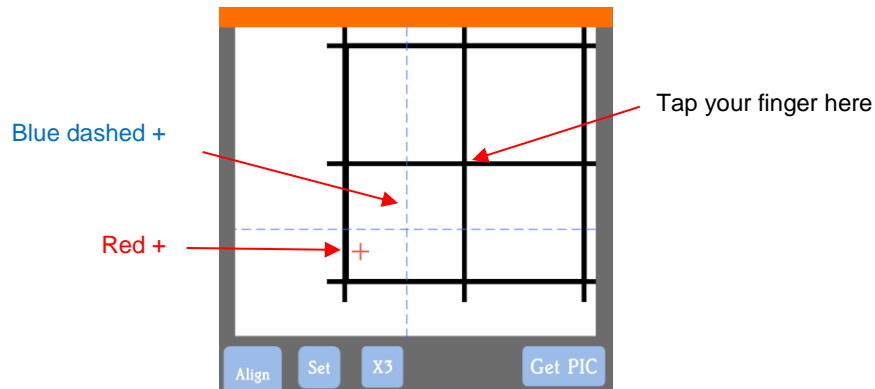

- (9) Tap your finger near the middle of the drawn test shape on the screen. This will move the red + close to that location:

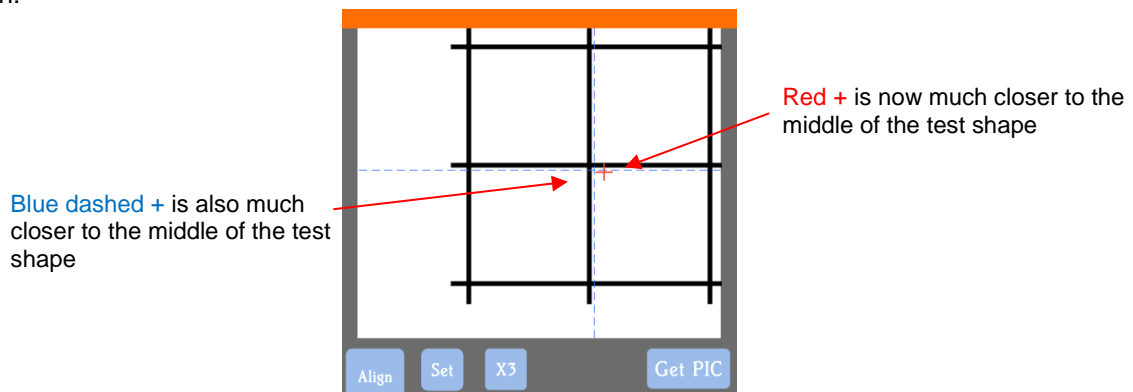

- (10) Press **OK**. A new photo will be taken and one of two things will happen:

- ◇ Situation 1: The red + is so close to the center that the Skycut will now take over and find the true center on its own. You will see the red + and the blue dashed + aligned in the center and the arrows (only) will return to their blue color. Additionally, the camera will now move over to the left side test shape and take a photo.
- ◇ Situation 2: The red + and the blue dashed + are still not aligned and the arrows around the **OK** button are still red. You will need to tap the center again and press **OK**. Continue, as needed, until the center is identified and the camera moves to the left side test shape and takes a photo.

- (11) Once Situation 1 is achieved and the camera has taken a photo on the left side, tap the center of the test shape on the screen and press **OK**. The camera will take over and locate the center on its own. The arrows (only) will turn blue:

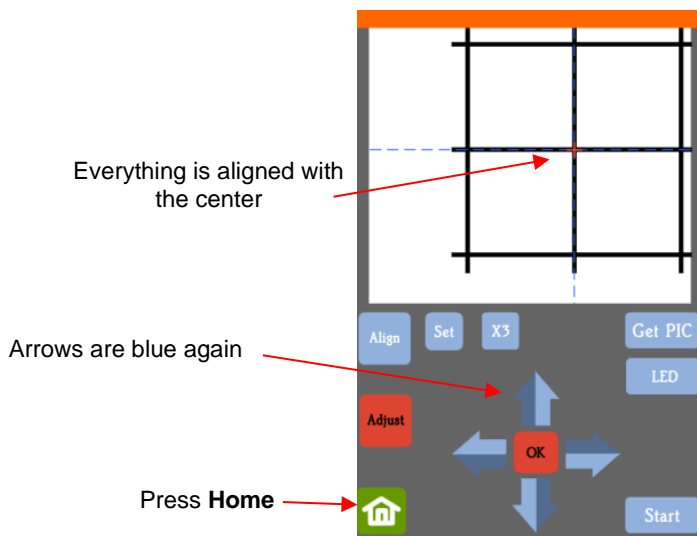

(12) Once the blue arrows appear, press the **Home** button and then press **Stop** on the **Main Screen** to save the calibration and conclude the process:

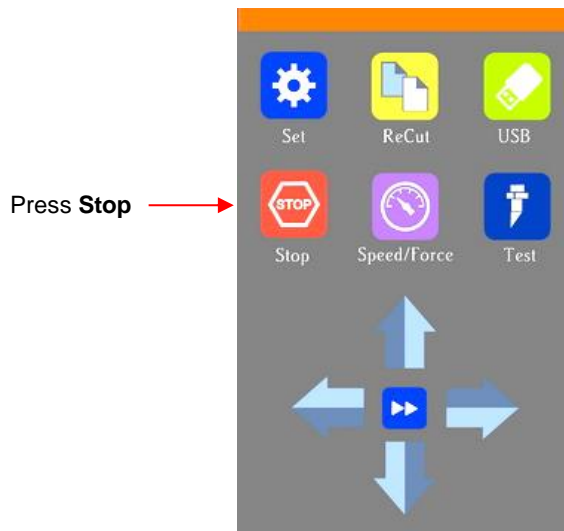

4.02 Drawing with the Test Pen

- With the Skycut, you can draw shapes and lettering with the test pen.
- If you wish to fill (i.e. color in) a shape, select the shape and click on the **Plugins** icon  and select **Engraving Module**. Refer to *Section 5.03* for instructions on how to adjust settings to create a line fill.
- Do not have the pen positioned too low in the blade holder seat or the tip of the pen could drag across the paper when moving from one shape to the next. Thus, use the 35 Post-It note method presented in *Section 2.01.3*.
- Make sure your shapes will not be drawn where any of the pinch wheels travel over the material. Otherwise, the ink might smear.

4.02.1 Draw and Cut on the Skycut D

- A draw-and-cut application involves using the test pen to draw shapes and then using the blade holder to cut them out. This rest of this section covers the process.
- In the following example, a design is selected from **General Clipart** and sized for the project. Then a contour is added using the instructions in *Section 5.01*:



- Note that the contour color (blue) differs from the design's **Fill** color (black). This is important so that the proper left versus right tool assignments can be made.
- Click on the **Cut, Plot, & Engrave Tools** icon and select **Send to Cutter**. In the **Send to be Cut** window, mark the option for **Assign Tools by Color**. You will then see the two colors, blue and black, appear in the **Cutting Tool Presets** list:

General Options

Separate by Color

Registration Marks Assign Tools by Color

Cutting Tool Presets

Color Name	Cutting Preset	Blade Type	Blade Preset
■ (Contour Cut Col...	(Default)		
■ Black	(Default)		

Colors used in project

Mark this option

No Preset selected...

- The layers will be processed in the order shown. However, because it makes more sense to draw first and cut second, the blue layer will be moved down. This is done by selecting the blue layer and clicking on the down arrow below:

Cutting Tool Presets

Color Name	Cutting Preset	Blade Type	Blade Preset
■ (Contour Cut Col...	(Default)		
■ Black	(Default)		

Select blue layer

Click the down arrow

No preset selected

- The tool assignment for each layer needs to be assigned. Click on the drop-down arrow in the **Preset** selection box and the following menu appears:

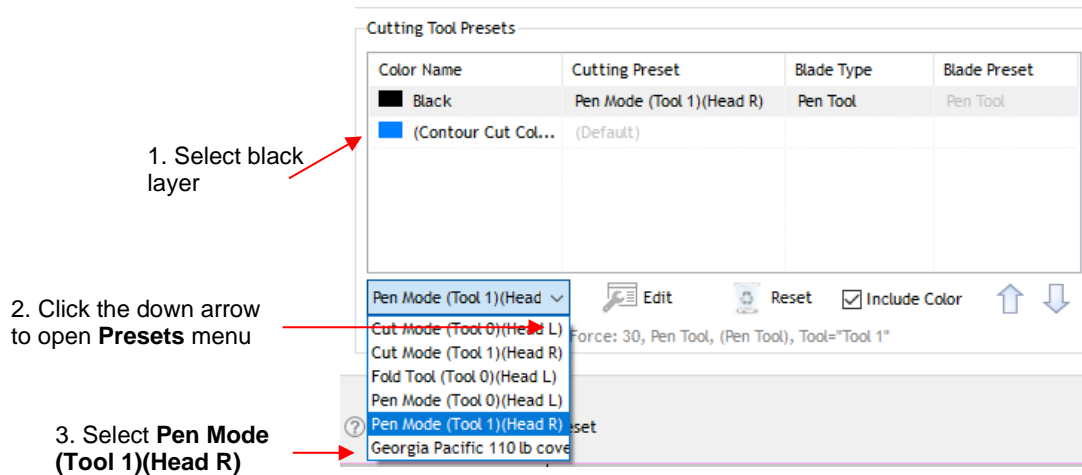

- Note that **Pen Mode (Tool 1)(Head R)** is selected since the pen will be mounted on the right side in the Skycut. Click on **Edit** to check for settings that are assigned. Remember that the speed settings need to be set on the control panel so uncheck any settings boxes and assign the **Force** on the control panel, as well:

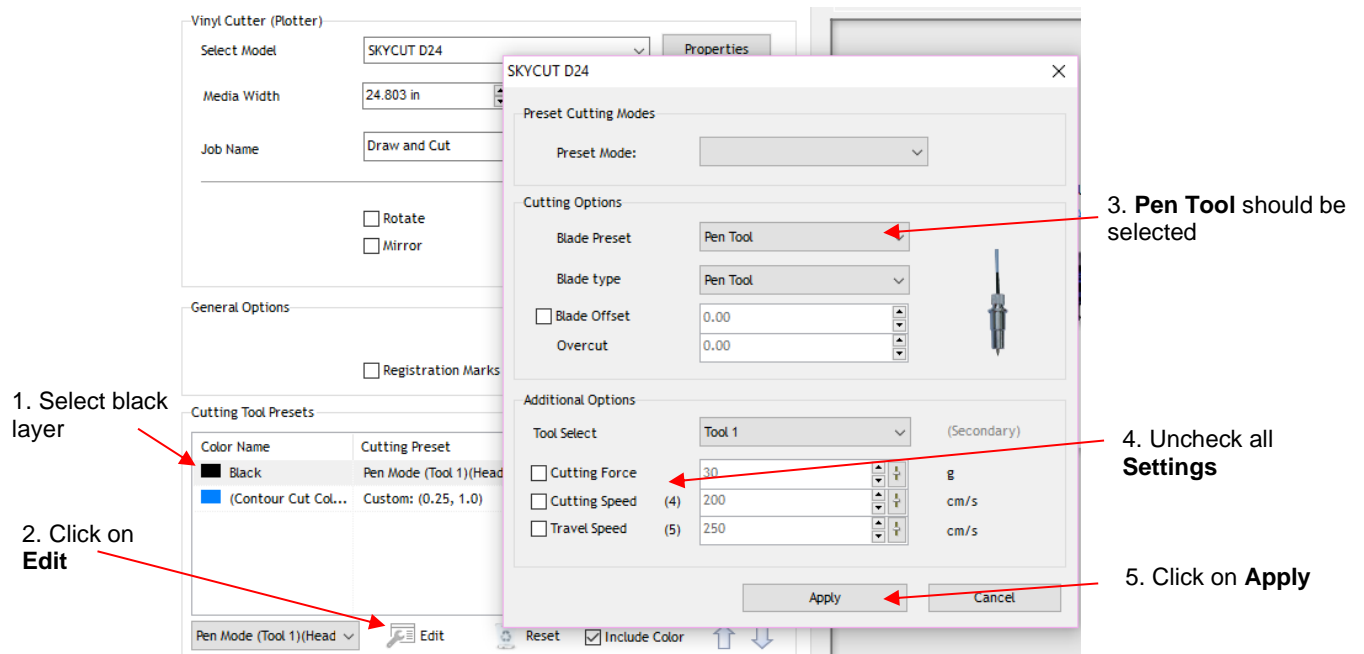

- Repeat the tool assignment for the blue layer, but select **Cut Mode (Tool 0)(Head L)** from the drop-down menu. Then click on the **Edit** button, verify that the correct blade is selected and, again, no cut settings are marked:

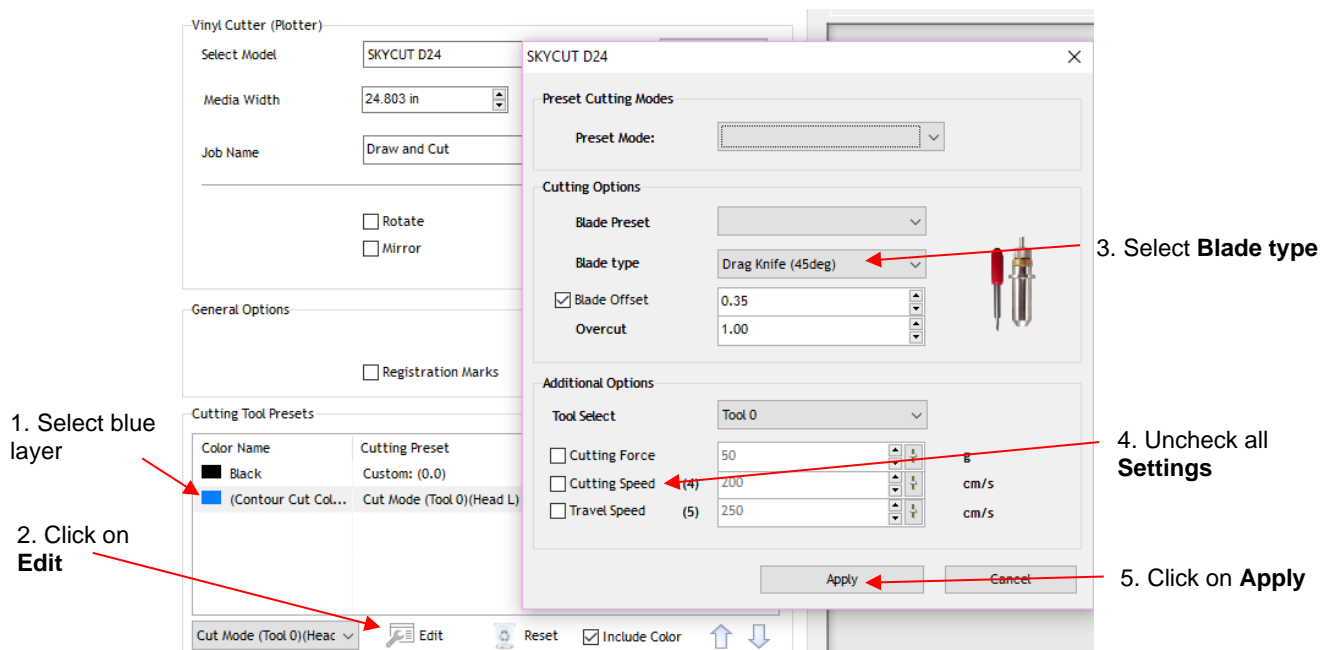

- After clicking on **Apply**, go to the Skycut's control panel and enter suitable **Force** and **Speed** settings for both the left side cutting and the right-side drawing:

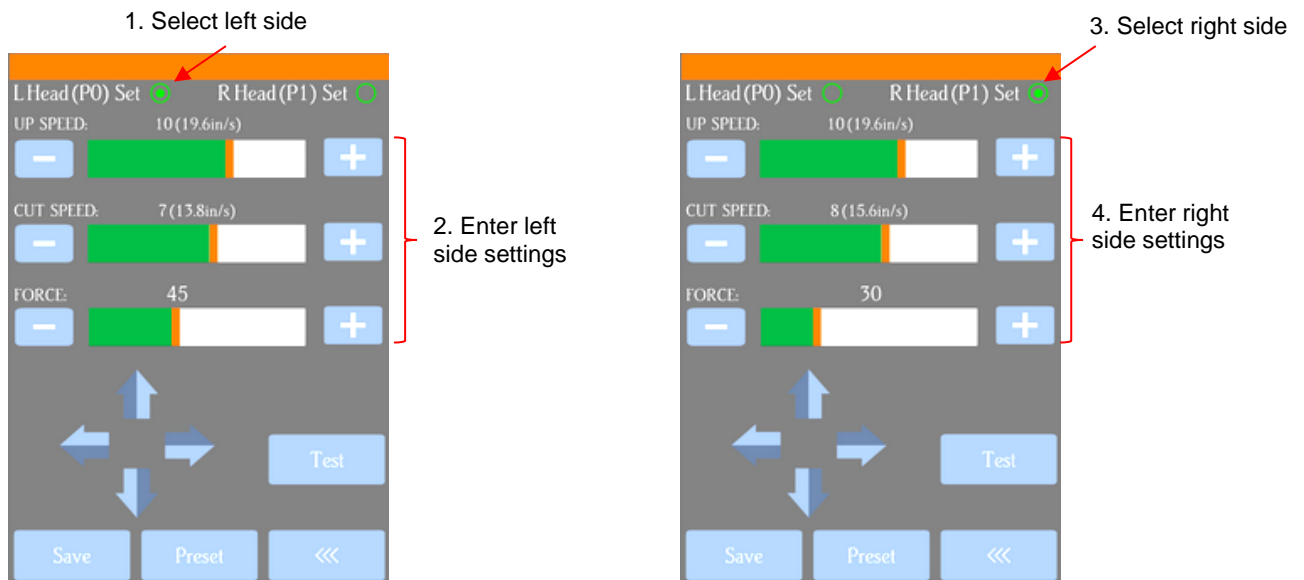

- Install the blade holder on the left and the test pen on the right. Set the origin based on the left side blade tip and then click on **Cut Now** in Signmaster.

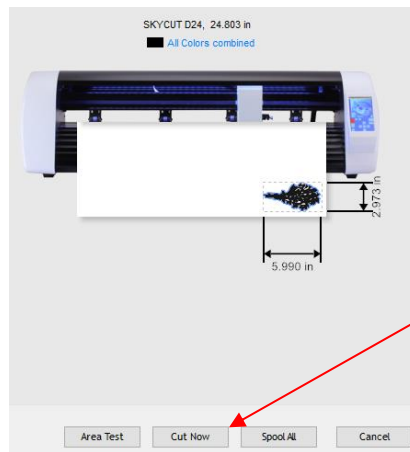

Click on **Cut Now**

- The flowers will be drawn with the test pen followed by a contour cut using the blade holder.

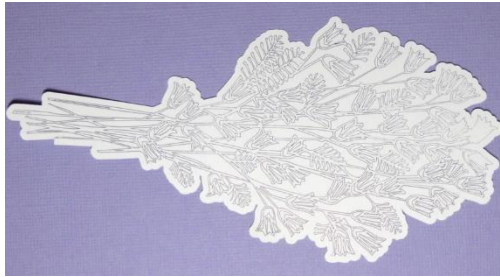

4.02.2 Draw and Cut on the Skycut V

- A draw-and-cut application involves using the test pen to draw shapes and then using the blade holder to cut them out. This rest of this section covers the process.
- In the following example, a design is selected from **General Clipart** and sized for the project. Then a contour is added using the instructions in *Section 5.01*:

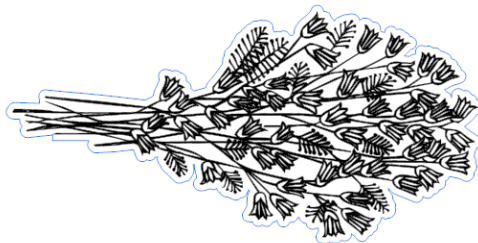

- Note that the contour color (blue) differs from the design's **Fill** color (black). This is important so that the draw and cut can occur separately, providing the opportunity to change out tools.
- Click on the **Cut, Plot, & Engrave Tools** icon and select **Send to Cutter**. In the **Send to be Cut** window, mark the option for **Assign Tools by Color**. You will then see the two colors, blue and black, appear in the **Cutting Tool Presets** list:

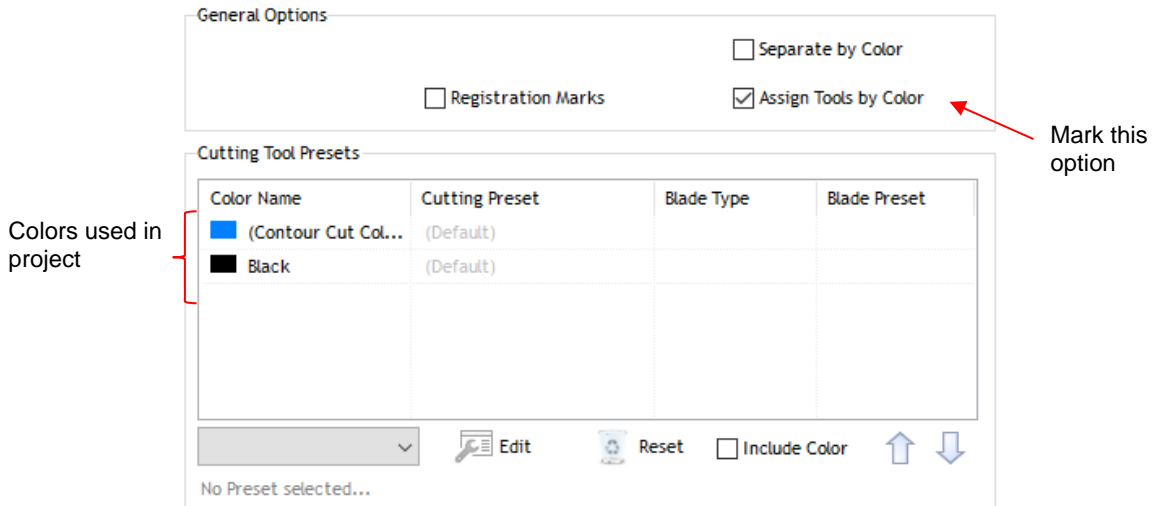

- The layers will be processed in the order shown. However, because it makes more sense to draw first and cut second, the blue layer will be moved down. This is done by selecting the blue layer and clicking on the down arrow below:

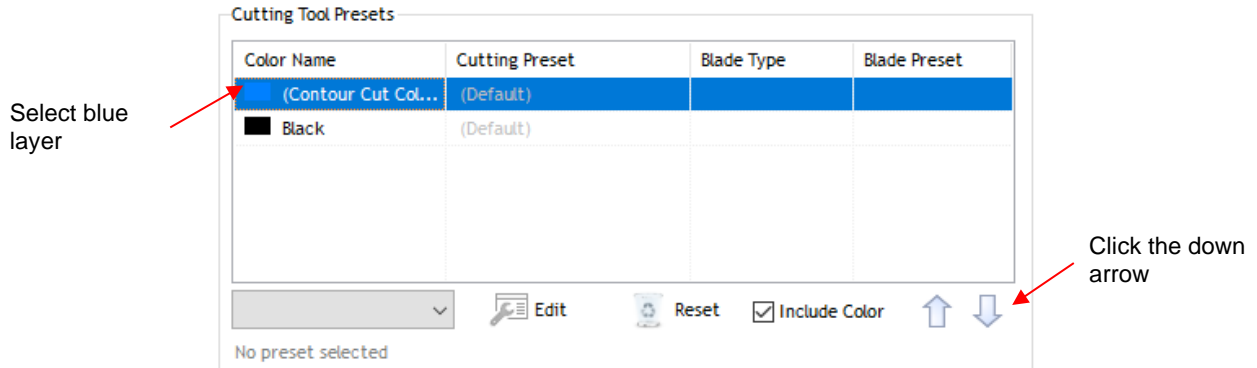

- The cut settings for each layer now need to be assigned. If settings have already been entered and saved as **Presets**, you only need to select from the **Preset** menu:

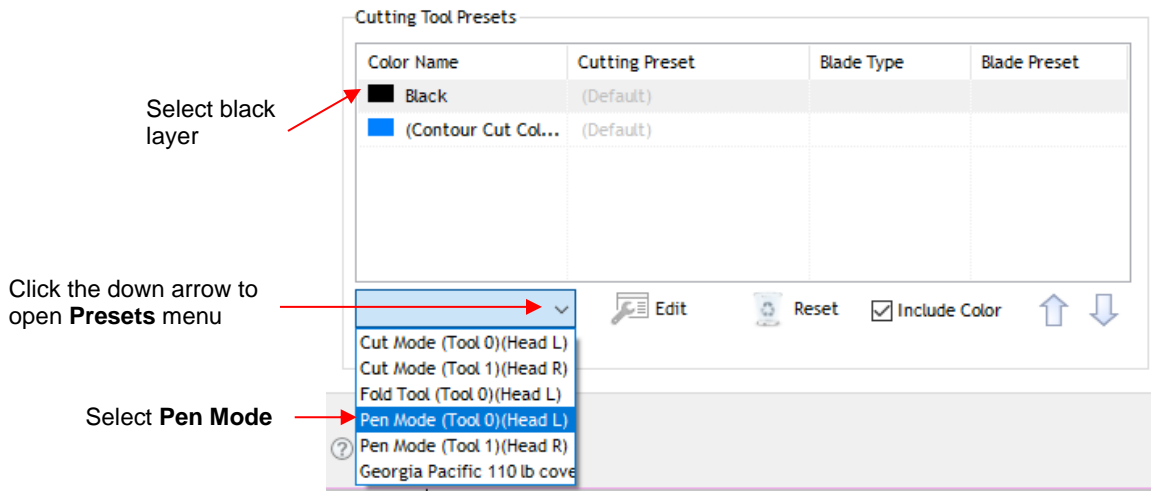

- If you need to enter new settings, which will be done for the contour cut (blue) layer, select that layer and click on **Edit** and the following window opens:

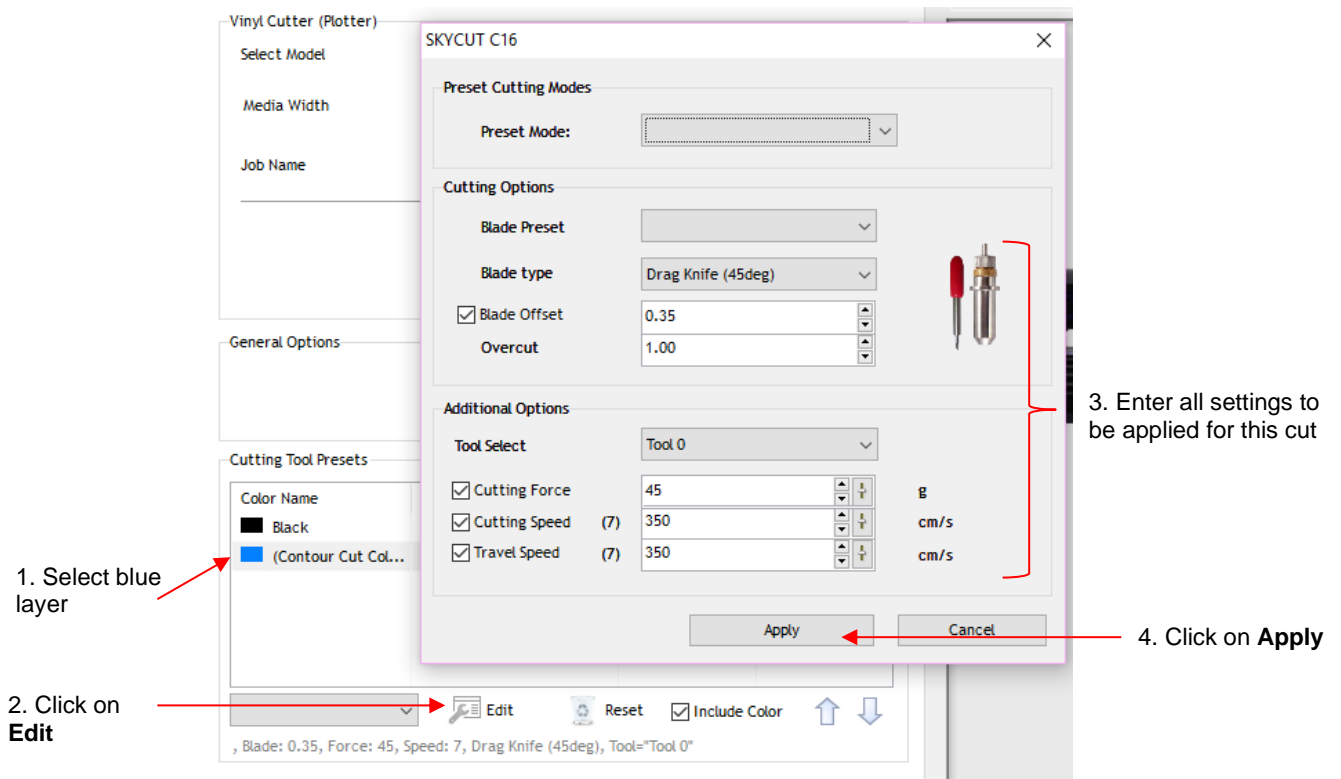

◇ **IMPORTANT:** Note that this window does not allow you to save the settings as a new **Preset**. Thus, if you will be cutting this material often, you might prefer to set up a preset for it using the instructions in *Section 2.04.2*.

- After clicking on **Apply**, you will see that both colors now have settings assigned. Because the blue layer is still selected, its settings show along the bottom:

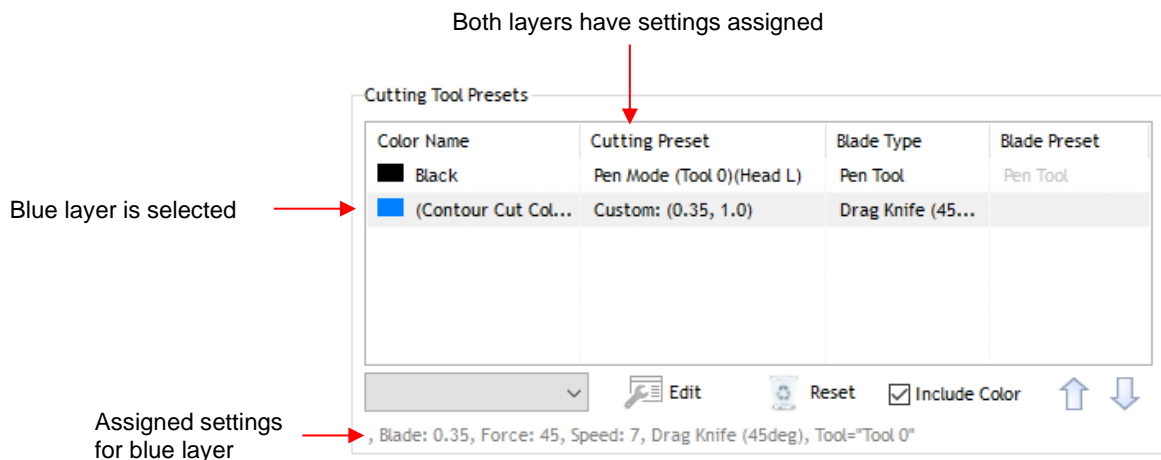

- Load the material into the Skycut. Click on **Cut Now** and you will be prompted to load the **Pen Tool**:

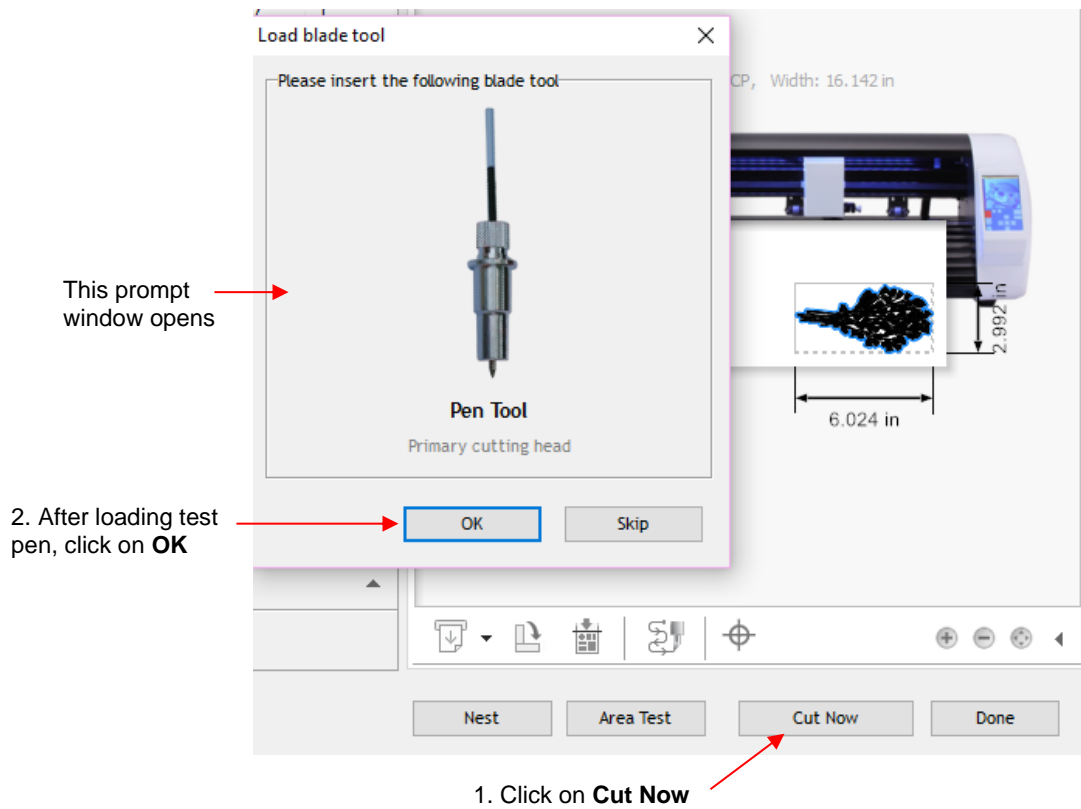

- Load the test pen into the Skycut, click on **OK**, and the design will begin drawing. The second prompt window will immediately open:

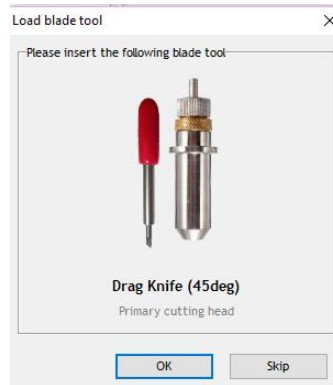

- As soon as the drawing process has ended, load the blade holder into the Skycut and proceed with the contour cut by clicking on **OK** in the prior window. Once completed, click on **Done** to close the **Send to be Cut** window.



4.03 Embossing and Scoring

4.03.1 General Info on Embossing

- The Skycut embossing tool has two different sized embossing heads. The smaller one is recommended when scoring cardstock for fold-up projects, such as pop-up cards, gift bags, and small boxes. Either head can be used for embossing shapes.



- When embossing cardstock, it is recommended that a soft material be placed beneath the paper or cardstock to allow a deeper impression to be made. One excellent material to use is non-slip shelf liner. Other materials which can be used include rhinestone rubber, craft foam, and felt. Make sure the material is well adhered to the mat (tape it down, if necessary). Then tape your paper or cardstock to the top of this material.
- When using the embossing tool for scoring fold-up projects, the paper or cardstock can be applied directly to the mat, just as you do for cutting. This makes it much simpler when you need to score and then immediately cut. Because the scoring may not be as deep on the underside of the paper or cardstock as the top side, fold all score lines (valley and mountain) forward to establish the fold on both sides. Then flip over and fold any mountain folds the opposite way. This especially works well on pop-up cards.
- Make sure you do some tests first to get the best settings for the scoring or embossing you need. For scoring cardstock, this typically involves a higher force (~75). If you have a soft material beneath your paper/cardstock, then a lower force will be used. As with the test pen, use the 35 Post-It note method presented in *Section 2.01.3* to install the embosser into the Skycut.

4.03.2 Score and Contour Cut Project on the Skycut D

- When a project involves both scoring and contour cutting, the layers need to be assigned as such using the **Custom Fill** menu. Otherwise, the **Contour Cut Wizard** window will only recognize the print layer. This section presents the steps required.
- In this tutorial, a fold up box project will be used as a typical example:

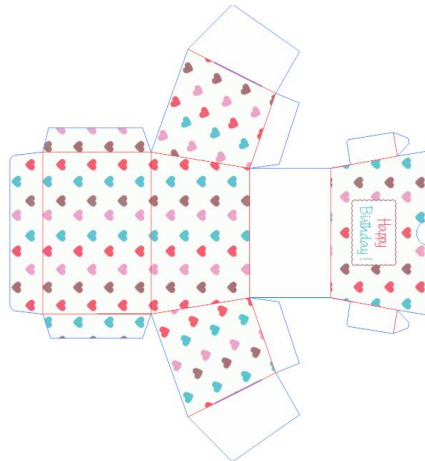



- Click on the **Objects** tab on the **Page Thumbnail Viewer** so that you can see the various shapes making up this project. In this example, there are two objects making up the score lines, one layer for the printing and one layer for the contour cut:

1. Click this blue arrow

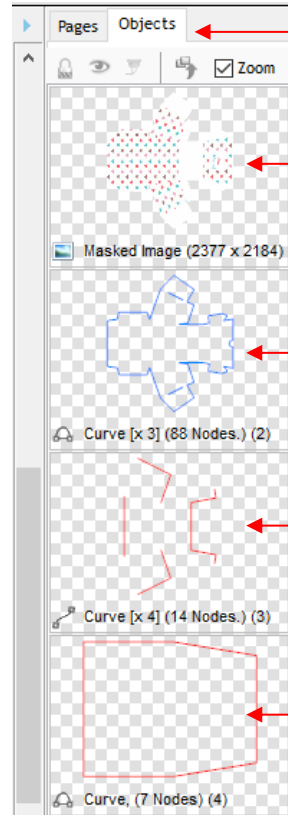

2. Click the **Objects** tab



- The cut layer and the two score layers need to be assigned as such. Select the blue outline cut layer and click on the **Custom Fill** icon  that is located on the **Palette**. Select **Cut Contour** from the drop-down menu:

Click here



Select **Cut Contour**

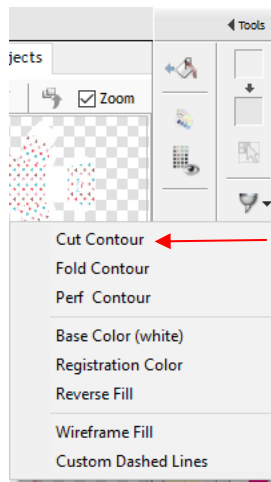

- Next, click on the first layer of score lines and select **Fold Contour** in the **Custom Fill** menu:

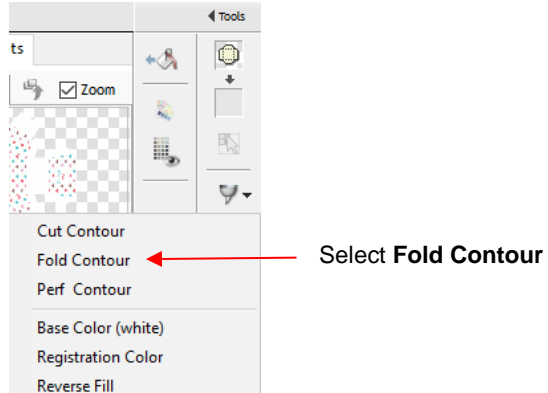

- Repeat the last step for the second layer of score lines. Note that you could also have selected both layers at once and assigned to **Fold Contour**.
- Go to the **Contour Cut Wizard** window and verify that the preview windows show the layers have been assigned:

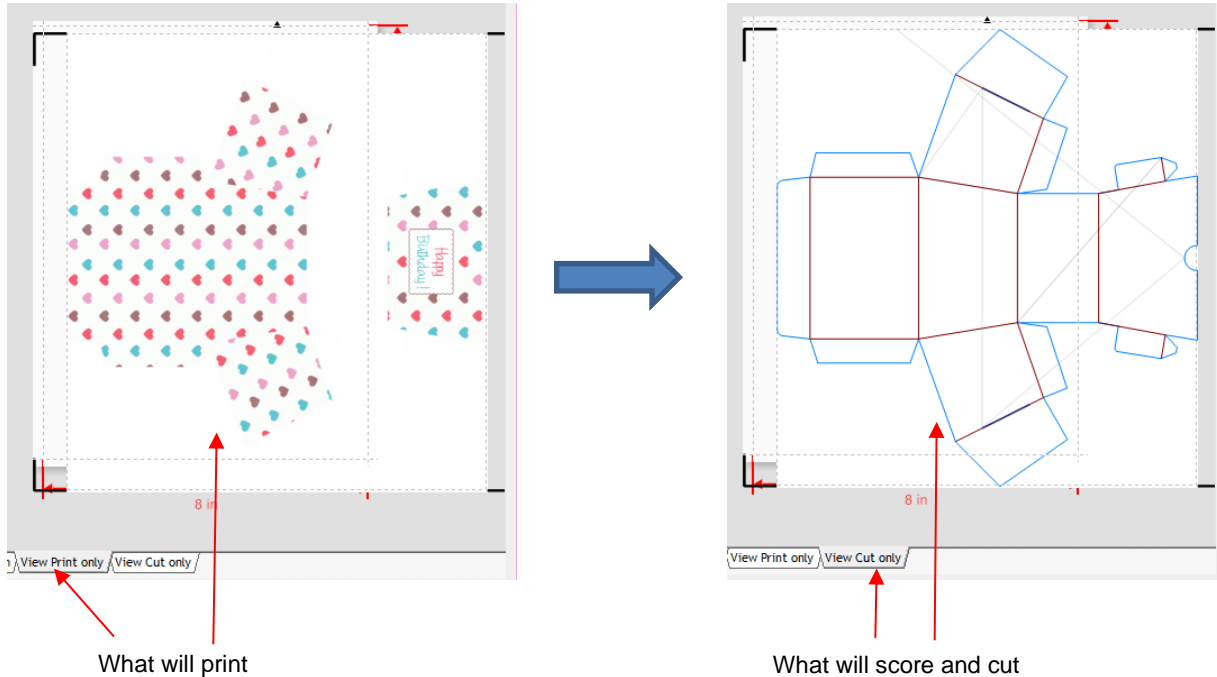

- Note that the 8" dimensions in the prior screenshot is red. The settings in the printer properties window need to be changed for this project, which is designed for A3 printing. Other settings, such as centering the project on the page and choosing the **Mark Position** should also be done, as presented in *Chapter 3*.

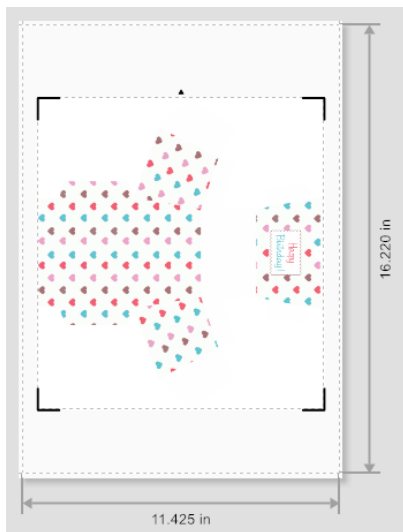

The previews for printing and for scoring/cutting now show the dimensions in black and all four registration marks in place.

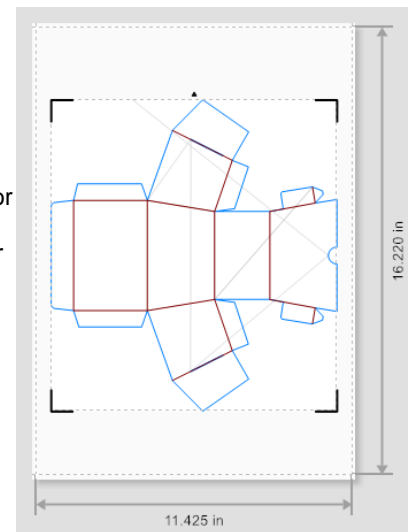

- Next, assign the left and right sides to the cut and score layers. This is virtually identical to the process that was used in *Section 4.02.1*, other than it is done from within the **Contour Cut Wizard** window. Click on the **Print Options** tab and arrange the score layer (red) to be carried out before the cut layer (blue):

Contour Cutting Wizard

Output Options **Print Options** Mark Options Templates

Printing Position

Use design size and position Auto center small jobs (A4 size)

Use Page Marks

Advanced Position

Left Position: 16.4 mm

Top Position: 62.8 mm

Cutting Tool Presets

Color Name	Cutting Preset	Blade Type	Blade Preset
■ Fold Contour	(Default)		
■ Cut Contour	(Default)		

 Include Contour

No preset selected

Select a layer, as needed →

Use the arrows to move that layer ←

- To assign the **Fold Contour** layer to the right side, select it, and then click on the drop-down arrow in the **Presets** box. Choose **Pen Mode (Tool 1)(Head R)** from the menu:

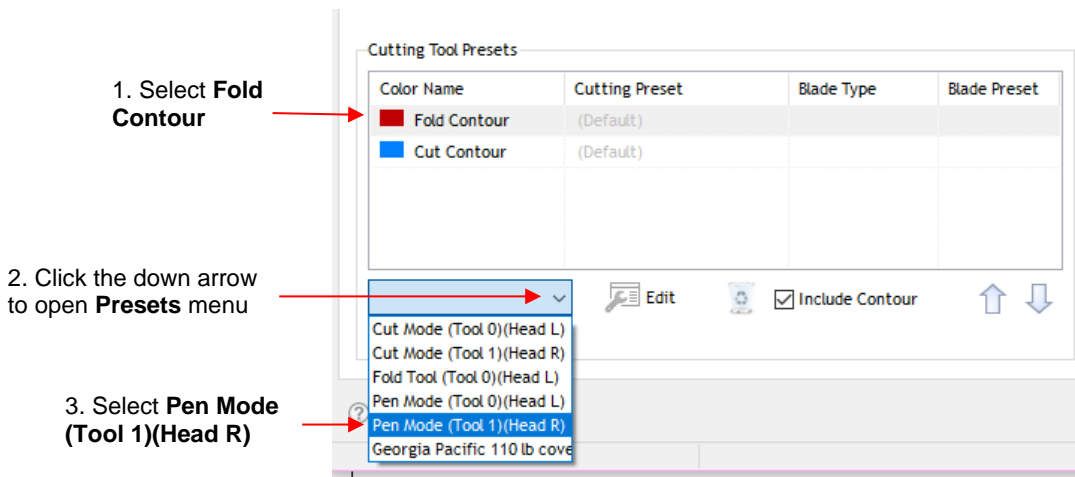

- Click on **Edit** and make sure the cut settings are unchecked as it is recommended that the force and speed settings be made on the Skycut control panel. Click on **Apply**:

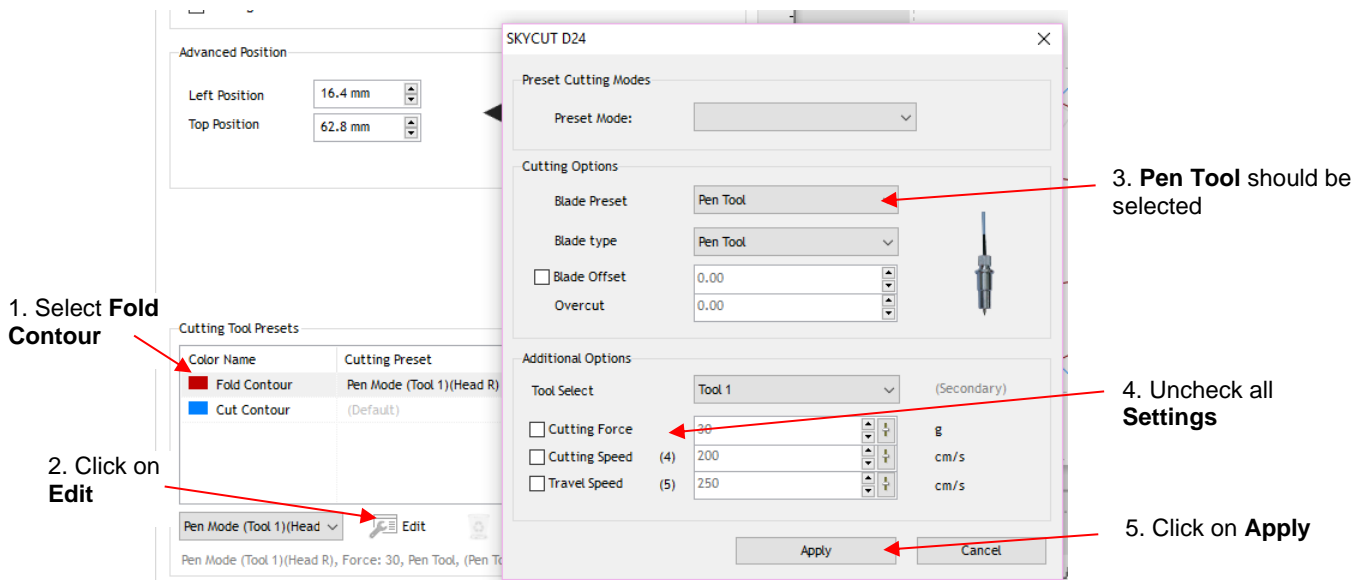

- Repeat for the **Cut Contour** layer. Select **Cut Mode (Tool 0)(Head L)** from the **Presets** drop-down menu:

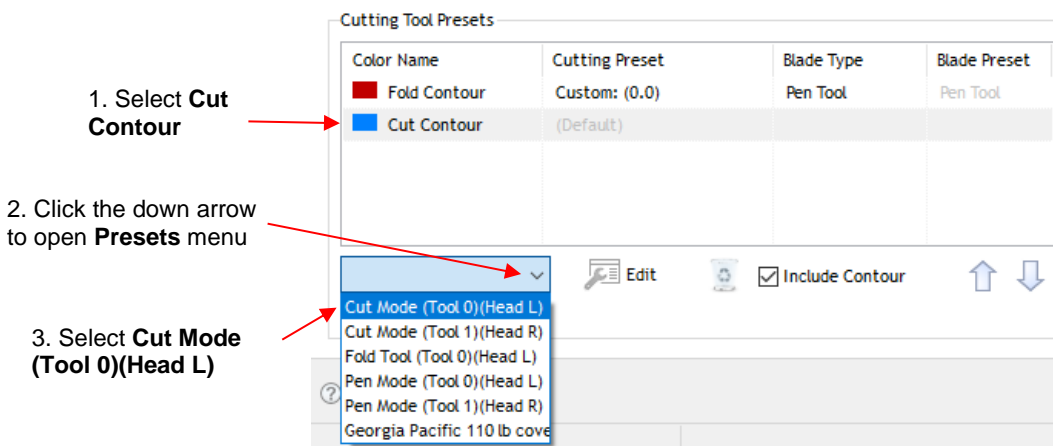

- Click on **Edit** and make sure the correct blade is selected, along with unmarking any cut settings. Click on **Apply** when done:

1. Select **Fold Contour**

2. Click on **Edit**

3. Select **Blade type**

4. Uncheck all **Settings**

5. Click on **Apply**

- After clicking on **Apply**, go to the Skycut's control panel and enter suitable **Force** and **Speed** settings for both the left side cutting and the right scoring:

1. Select left side

2. Enter left side cut settings

3. Select right side

4. Enter right side score settings

- Load the blade holder onto the left side and the scorer onto the right side. Print the project using the same options and instructions from *Chapter 3*. Place the printout onto the cutting mat with the printed arrow pointed downwards. Proceed with the process by placing the blade tip near the lower right registration mark and click on **Cut Now**.
- Remove the cut project and fold all score lines forward, as if they were valley folds. Then fold back any mountain folds and continue to assemble the project:



4.03.3 Embossing Paper or Cardstock

- When embossing paper or cardstock, it is recommended that you use an **Outline** effect to create several very small outlines at a thickness of, say, 0.01” (0.25 mm). These tiny offset lines will then produce a slightly thicker overall outline of your shapes. This works better than line-filled embossing which can stress the cardstock and cause wrinkling. Here are the steps:

◇ Create the shape you wish to emboss. In this example, the number 25 is used:

25

◇ Select the shape and click on the **Plugins** icon  and select **Outlining Module**. The following window opens:

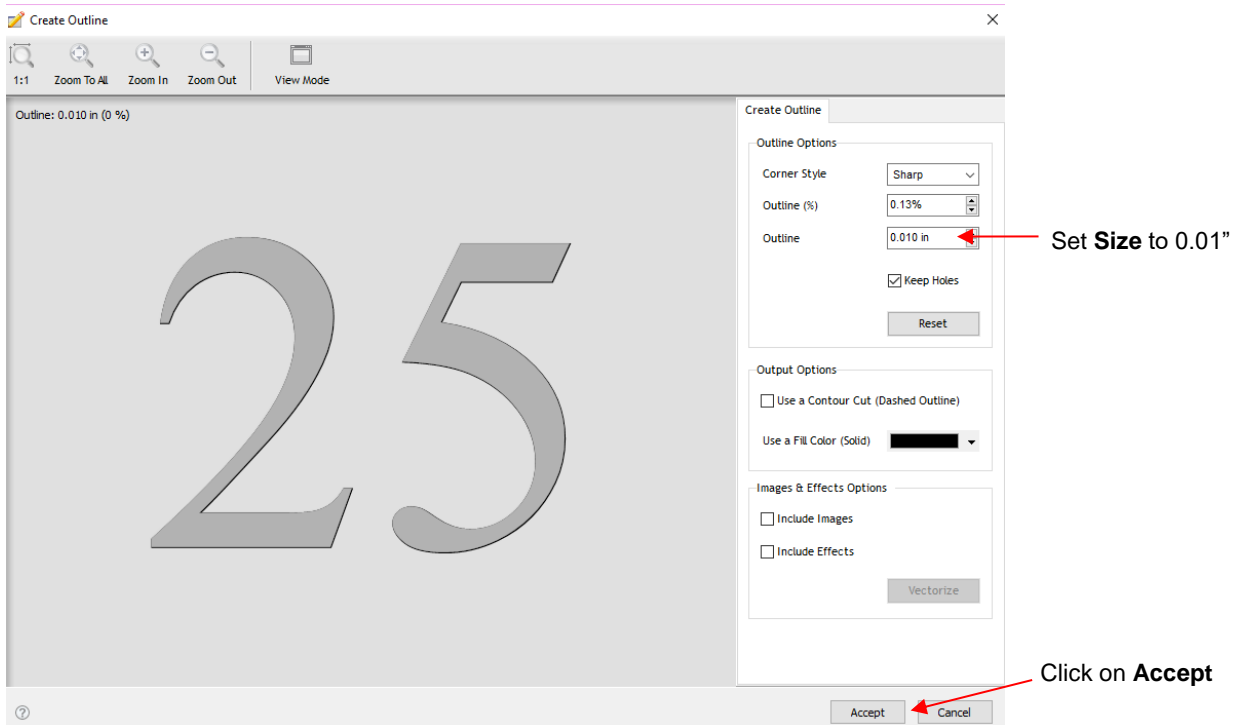

- ◇ After clicking on **Accept**, use the **Objects** panel to select the new outline layer and repeat the process to add a second outline. Now you have three versions of the shape, each one slightly outset from the other. Thus, when using the embossing tool, this will result in a thicker outline made of this shape.
- ◇ **Important:** don't forget to mark the **Mirror** option in the **Send to be Cut** window (or apply **Arrange>Mirror & Rotate>Mirror Horizontally**) so that when you flip over the cardstock after embossing, the design will “read correctly.”

4.04 Scratch Engraving

- The Skycut engraving tool can be used to engrave vellum, foils, acrylic, and most metals, including trophy labels, dog tags, and jewelry charms.



- On softer metals, you may not want the engraving tip too far above the metal as it can leave pock marks when it drops to start engraving. If possible, test on scraps first.
- To design an engraving fill pattern, use the **Engraving Module**. Refer to *Section 5.03*

4.04.1 Engraving a Metal Tag

- When engraving items that are already cut (such as metal tags, trophy plates, charms, etc.), it's very important to have precise alignment before proceeding. Therefore, the camera on the Skycut will be used to set the origin for engraving. If you haven't already calibrated the camera, go to *Section 3.03*.
- The following is a list of the items you'll need for this kind of an application:
 - ◇ The item to be engraved
 - ◇ The Skycut engraving tool
 - ◇ Double sided tape to secure the item to the cutting mat. Thermo-web is perfect for this.

- Create a replica of the item to be engraved:

- ◇ If it's something simple, like a square or a rectangle, use the basic shapes available in SignMaster:



- ◇ If it's not a shape that can easily be recreated in SignMaster, then trace it onto paper:



- ◇ Scan or photograph the trace and use the instructions in *Section 5.01* to import the scan and create a contour of the heart:



Imported scan



Tracing from **Create Contour Cut** window

- ***IMPORTANT:*** Carefully measure the actual tag and compare it to the dimensions of the contour. Adjust the size of the contour if needed.
- Create the design. In this case both text and a vector shape of a bone are added:



- Because a filled engraving is desired, select the text and the bone shape and use the **Engraving Module** to fill the design with lines. Details on this function are presented in *Section 5.03*.



- To arrange the design in the bottom corner of the **Page**, click on **Snap** in the middle taskbar and select **Page**:

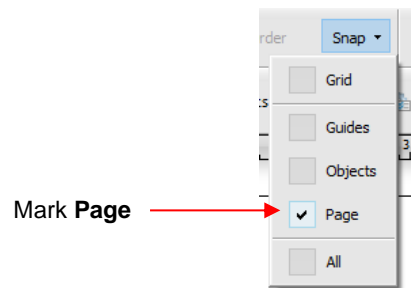

- With both the heart and the design selected, drag to the lower right corner until it snaps to the right and bottom sides of the **Page / Drawing Area** (Note: to better illustrate placement on the page and later in the **Preview**, the design has been made much larger. In reality the design is only about an inch in size):

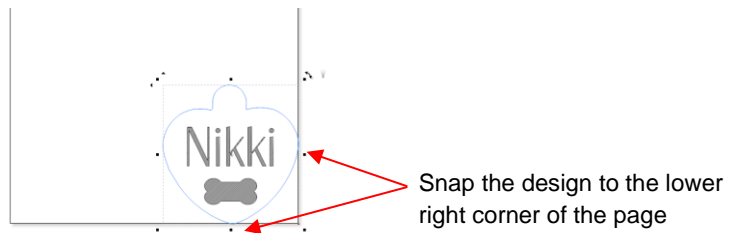

- Select only the design and not the heart tag shape. In the **Send to be Cut** window, mark the option for **Absolute (position)** so that the design will be positioned the same distance from the origin as it is from the corner of the **Page / Drawing Area**. Also, verify that **Assign Tools by Color** is not marked:

Check **Absolute (position)**

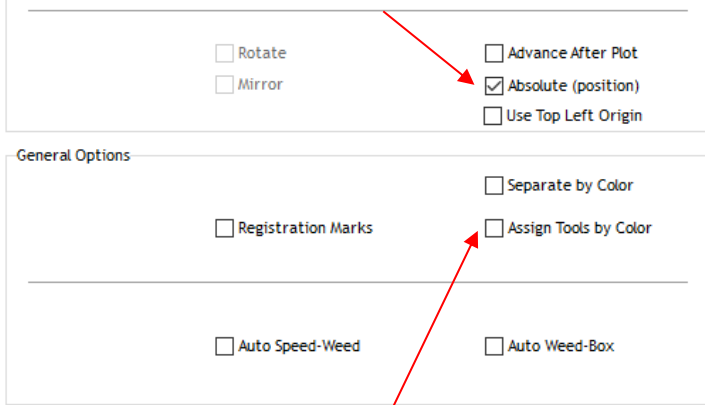

Verify **Assign Tools by Color** is not checked

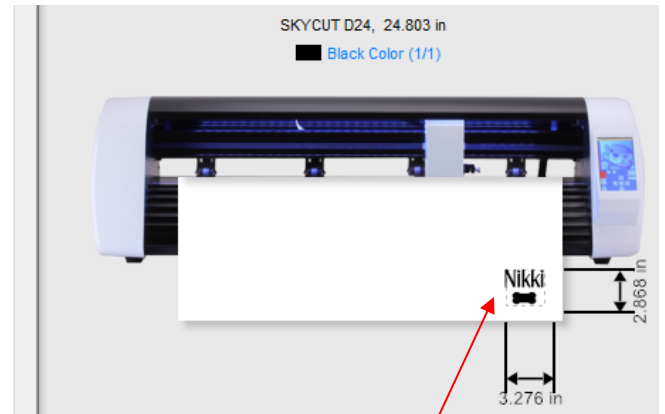

Design is in same location as on the **Page**

- On the **Cutter Control** tab, uncheck **Blade Offset** as it's not needed when using the engraving tool:

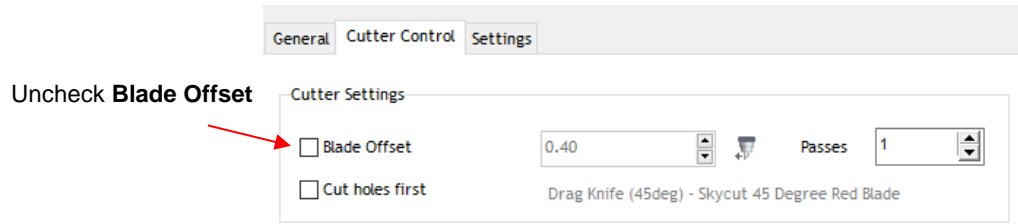

- On the control panel, click on the **Speed/Force** icon and enter a **Speed** of 10 and a **Force** of 40 for the engraving. Note that with your own testing, you may need to alter these settings.
- The metal tag needs to be very firmly attached to the cutting mat. Place strips of double-sided tape onto the mat, where the tag will be mounted:

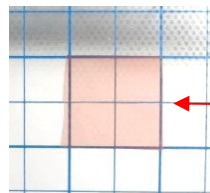

Double sided tape is placed on the mat to cover the size of the tag (note: the pink liner hasn't yet been removed from the top of the tape)

- When placing the tag onto the mat, align the rightmost side of the tag with a vertical grid line and the bottommost side of the tag with a horizontal grid line. The intersection of the two gridlines will be the origin for the engraving process:

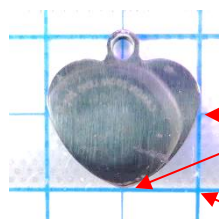

Align the tag with the grid lines on the mat

The origin will be set at this intersection

- Load the mat into the Skycut and be very precise in alignment by using the ruler to make sure the mat is perfectly straight:

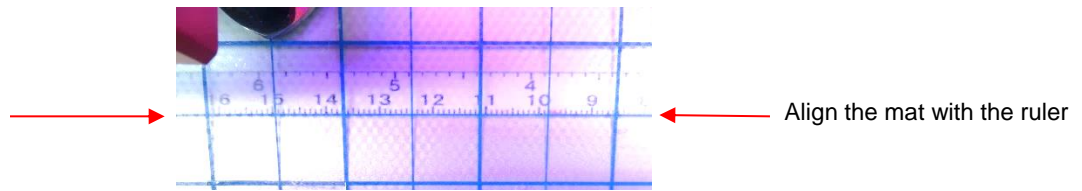

- Load the engraver into the Skycut using ~30 Post-It notes (or sheets of copy paper), making sure the notes are on top of the tag.
- Move the cutting head so that the engraver tip is over the intersection of the two grid lines bounding the tag. Then use the camera instructions in *Section 2.05.1* to set the origin even more precisely by getting the **blue dashed +** in the middle of the grid intersection:

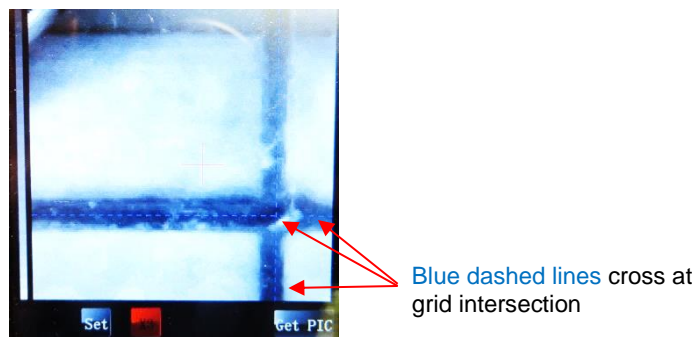

- After clicking on **Home**, press down on the engraver and verify, once more, that the correct grid intersection was used. Back in SignMaster, click on **Cut Now** and the engraving process will be carried out.:



4.05 Settings Form for Accessory Tools

<u>Application/Material</u>	<u>Tool</u>	<u>Force</u>	<u>Speed (Cut/Up)</u>	<u># Passes</u>	<u>Surface</u>	<u>Other Comments</u>

5. SignMaster Functions of Interest

5.00 Quick Reference for Chapter 5

- How to add a contour cut: *Section 5.01*
- How to node edit a contour: *Section 5.01.2*
- How to add a contour cut to a vector image: *Section 5.02*
- How to fill a design with engraving lines: *Section 5.03*

5.01 Adding a Contour Cut Line to an Imported Raster Image

- Graphics such as JPG, PNG, and BMP files are often used for print and cut (contour cut) applications. Because these types of files are raster images (versus vector images), the images must be traced. This is done through a process called vectorization.

5.01.1 Step-by-Step Tracing Process

- The following steps are a sample tutorial using the **Create Contour Cut** feature in SignMaster:
 - (1) For this project, go to [this link](#). After extracting, you will find several images that can be used as easy samples for tracing.
 - (2) To import a graphic file, go to **File>Import>File** and select the graphic to be traced. Left click anywhere in the **Drawing Area** to place the image:



- (3) With the graphic selected, click on the **Contour Cutting** icon  and select **Create Cut Contour**. A popup window will open and you will respond **Yes**:

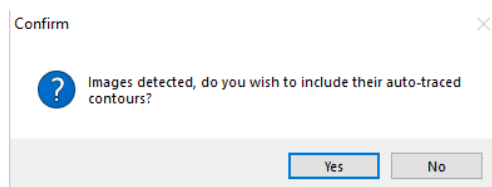

- (4) The **Image Contour Tracer** window displays the various settings available for adding a cut line to the graphic:

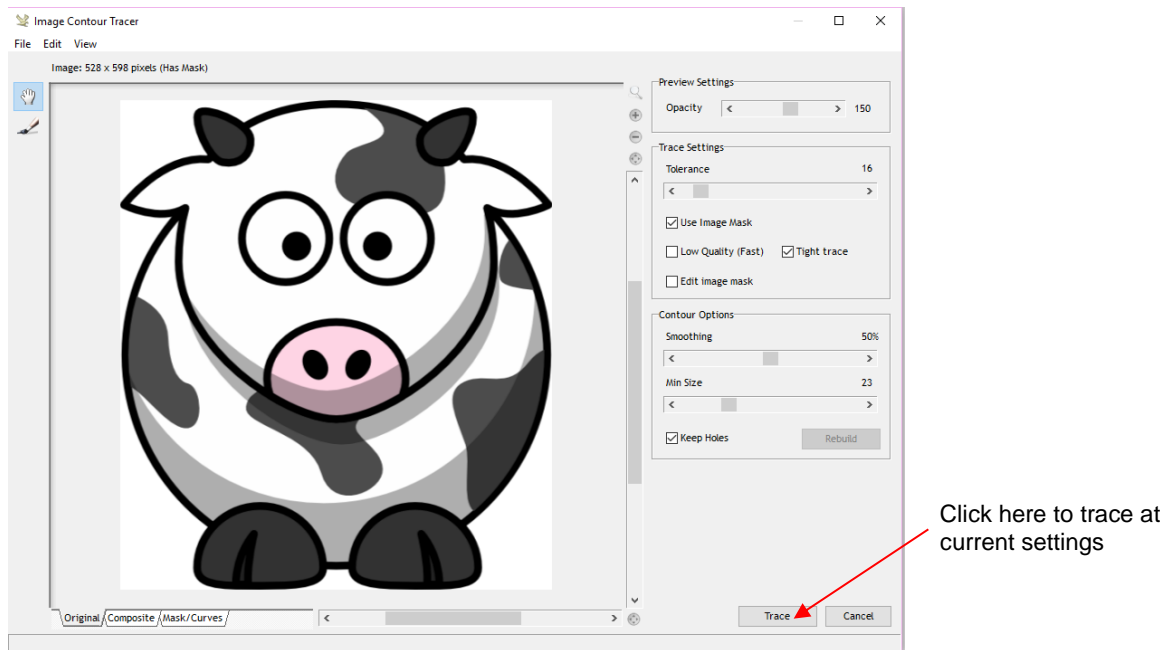

(5) Without making any changes, click on the **Trace** button to get a preliminary trace which will indicate which settings, if any, need adjustment. The blue line indicates what will cut based on the default settings shown:

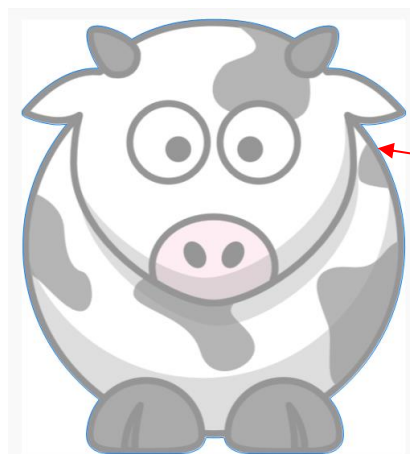

Carefully check blue cut line:

- Are all needed parts traced?
- Is trace line a tight enough fit?

(6) To see the trace line a little more clearly, adjust the **Opacity** setting at the top. If the “fit” isn’t tight enough, decrease the **Smoothing** setting. After making changes, click **Retrace** to return to the original tracing window and then click on **Trace** again:

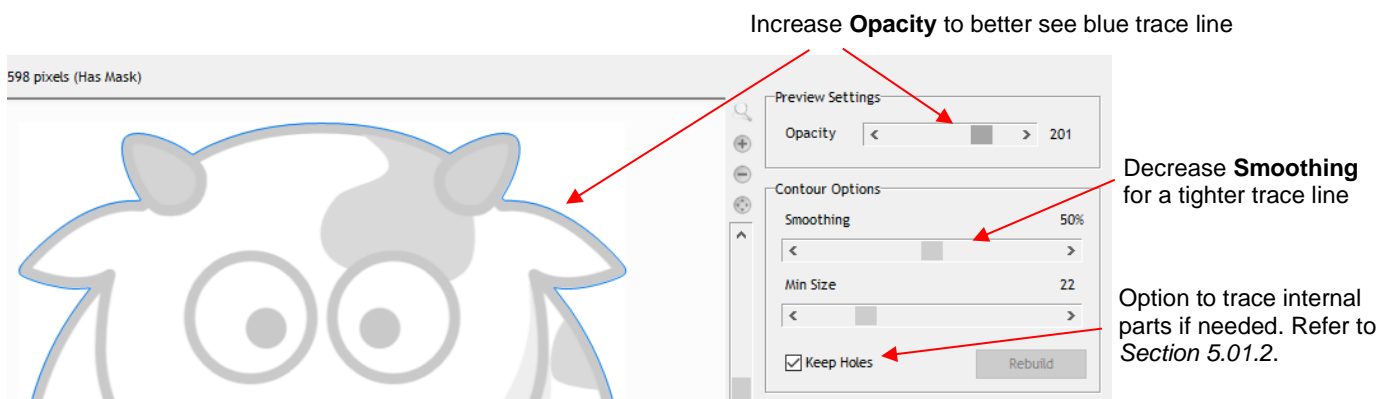

- (7) After making any changes, click on **Retrace** at the bottom of the screen. On the other hand, if you are happy with the trace results, click on **Apply**:



Click on **Retrace** to adjust to new settings

- (8) If you selected **Retrace**, a **Composite** view of the results will appear where blue indicates the part that will be cut out and red indicates the waste material. You can go back to seeing the prior view by clicking on the **Original** tab at the bottom. Click on **Trace** to apply the new settings.

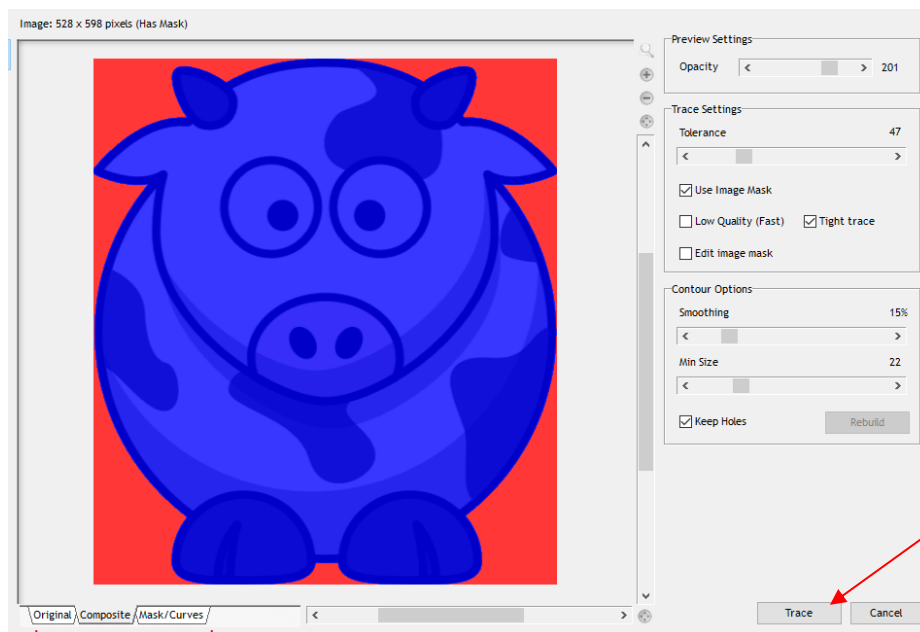

Alternate viewing options

- (9) After clicking on **Apply**, a new group of settings appear, giving you additional options such as:
- ◇ Whether the cut line is continuous or perforated
 - ◇ Whether the cut line fits the image tightly, or is offset a distance or inset a distance
 - ◇ Whether internal cut paths should be removed
 - ◇ The cornering shape of the contour cut (rounded, beveled, mitered, etc.)

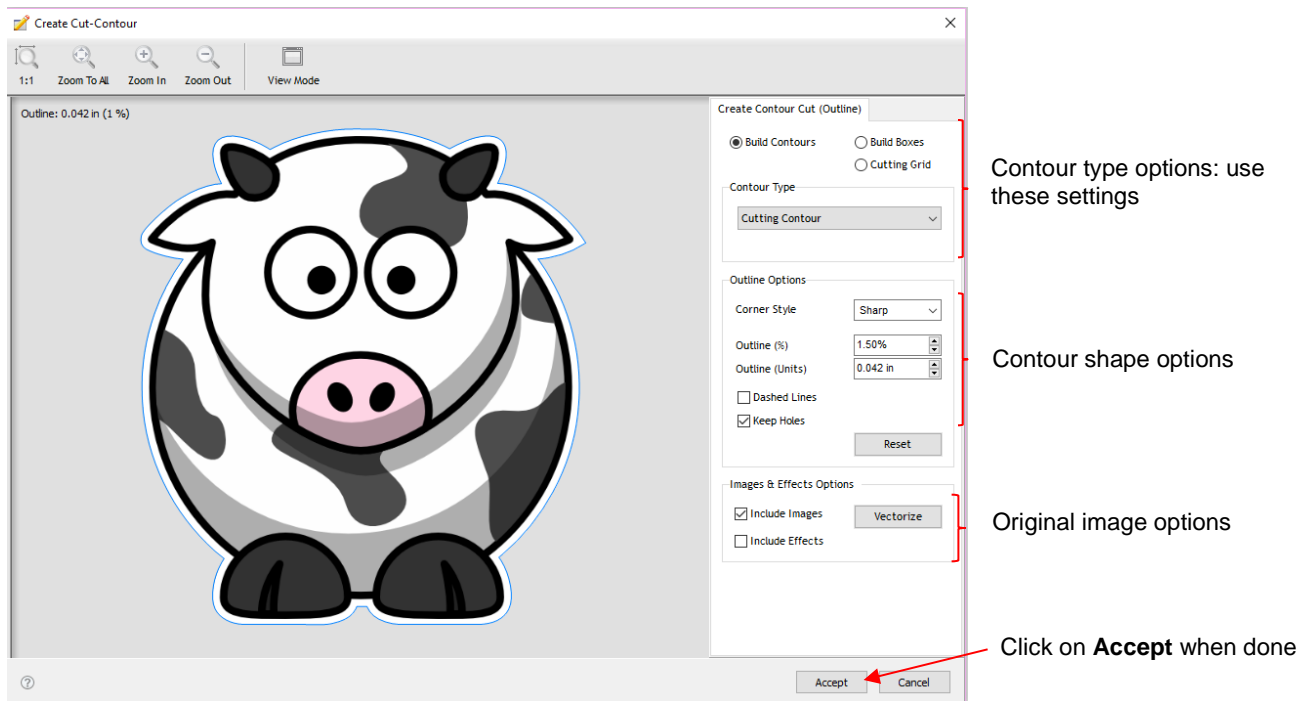

- ◇ Choose a **Corner Style**, as desired. For the **Outline %** or **Outline Units** (size), note the following:
 - Set to 0 if the cut line should align with the edges of the printed image
 - Set to a positive number for a contour cut around the outside of the printed image
 - Set to a negative number (normally very small) to cut slightly inside the printed image

(10) Click on **Accept** after making any changes and you will be returned to the **Drawing Area**. If you click on the **Objects** tab on the **Page Thumbnail Viewer**, you will now see both the original image and the contour cut line:

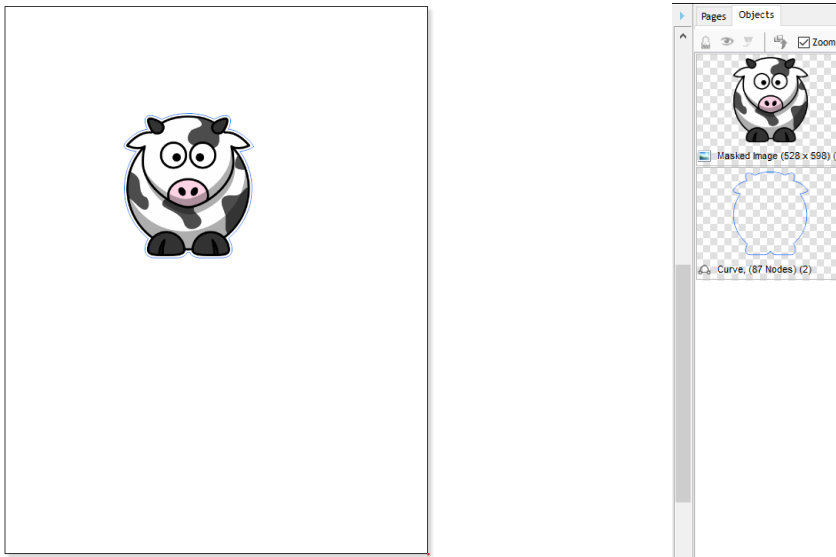

- To print and cut this type of design, refer back to *Sections 3.03* and *3.04*.

5.01.2 Editing a Trace

- Occasionally you may find a need to edit the tracing/contour cut created. This section presents two examples.
- Contour cut doesn't fit the original graphic in certain spots
 - ◇ In the following example, the *Cartoon Owl* image will be used:



- ◇ During the process of tracing, it was found that the bottoms of the owl's feet weren't rounded like in the original image. Even trying different adjustments to **Smoothing** didn't result in the desired fit. Note that a slight inline was applied to improve the accuracy of the fit but the bottom of the feet still need tweaking:



Trace line is flat along the bottom of owl's feet

- ◇ With the trace line selected, click on the **Node Edit Tools** icon  and the nodes making up the path of the cut will appear. Drag nodes, as needed, so that curves are formed:

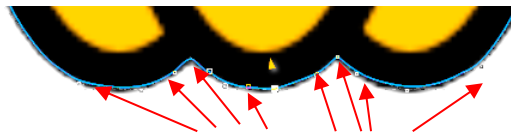

Drag nodes to create curves

- Contour cut contains paths you want deleted

- ◇ In the following example, a crab cartoon from *Doodle Dragon Studios* is traced:

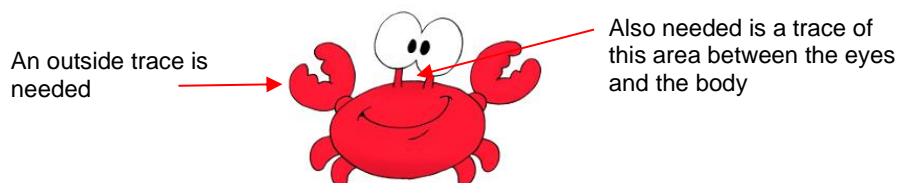

- ◇ The issue in this example is that the space below the eyes should be cut out but not other internal shapes, such as the pupils of the eyes. Note the difference in what will be cut between marking and not marking the **Keep Holes** option in the **Create Cut-Contour** window:

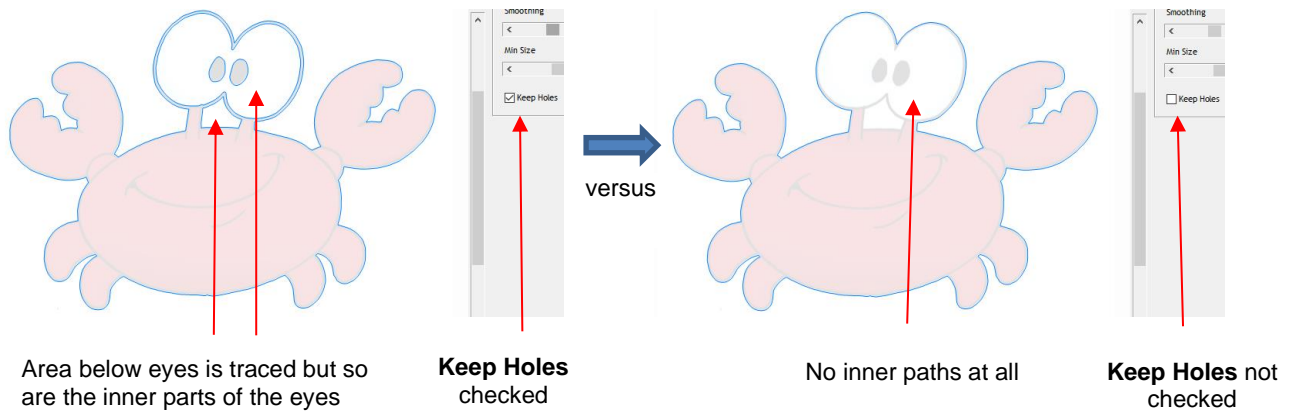

- ◇ The first option, **Keep Holes**, needs to be selected so that the area beneath the eyes is traced. After accepting the trace, click on the **Objects** tab on the **Page Thumbnail Viewer** and hide the original graphic. You will now only see the contour in the **Drawing Area**:

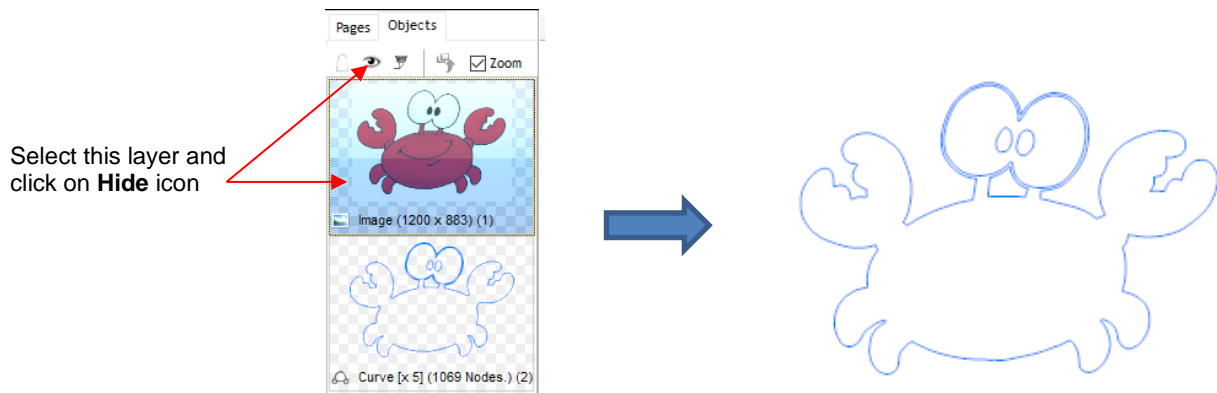

- ◇ Select the contour and go to **Curves>Break Apart**. The individual paths will now be separate layers on the **Objects** tab and you can delete each one that is not needed:

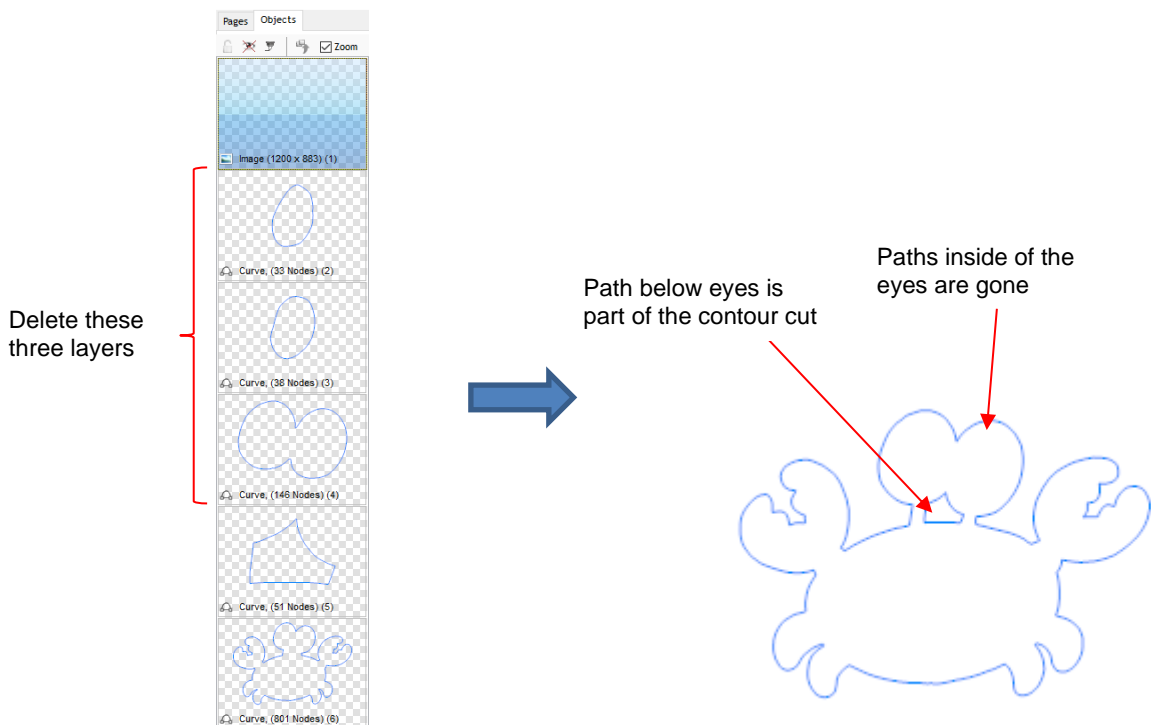

5.02 Adding a Contour Cut to a Vector Image

- As mentioned in *Section 3.05.2*, vector images require a contour cut assignment in print and cut applications. For example, the following Batman SVG file is imported into Signmaster and then the **Contour Cut Wizard** window is opened. Note that comparing the **View Print only** preview with the **View Cut only** preview indicates that the vector file is ready to print but there's no cut line for the design:

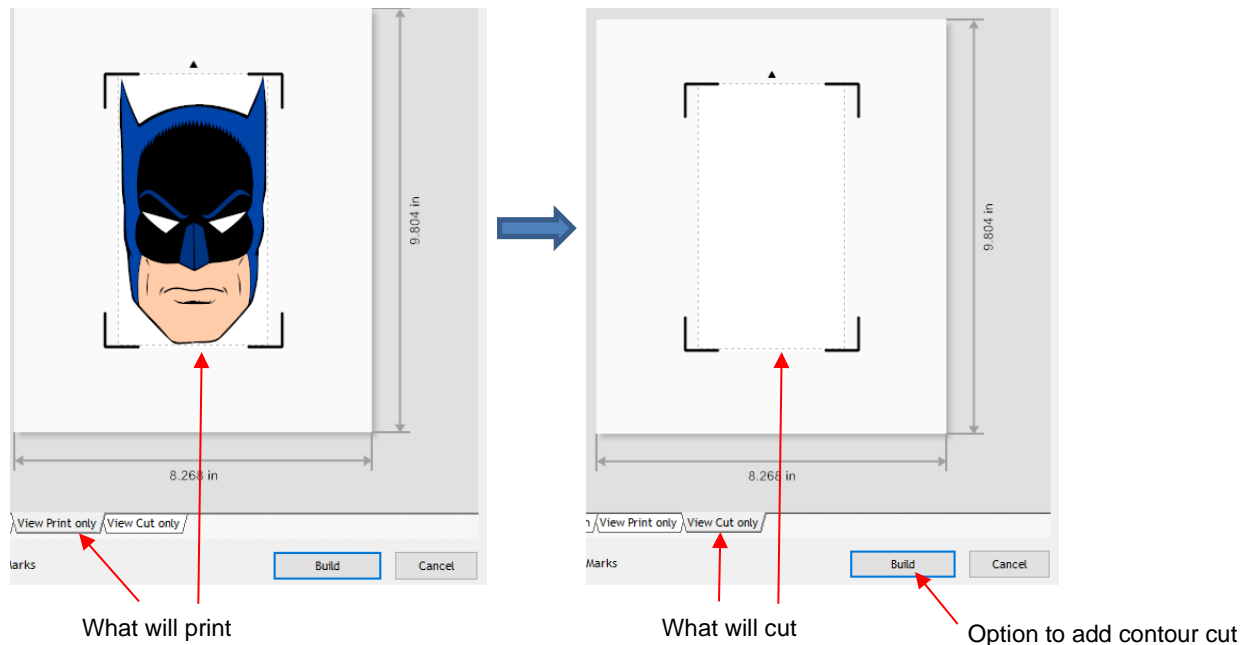

- There are two situations to consider:
 - ◇ A contour cut will be added to follow the printed design (*Section 5.02.1*)
 - ◇ A contour cut will be added and it will be offset from the printed design (*Section 5.02.2*)

5.02.1 Contour Cut Which Follows the Printed Design

- Upon importing the SVG file, open the **Objects** tab of the **Page Thumbnail Viewer** to display the various shapes in the file:

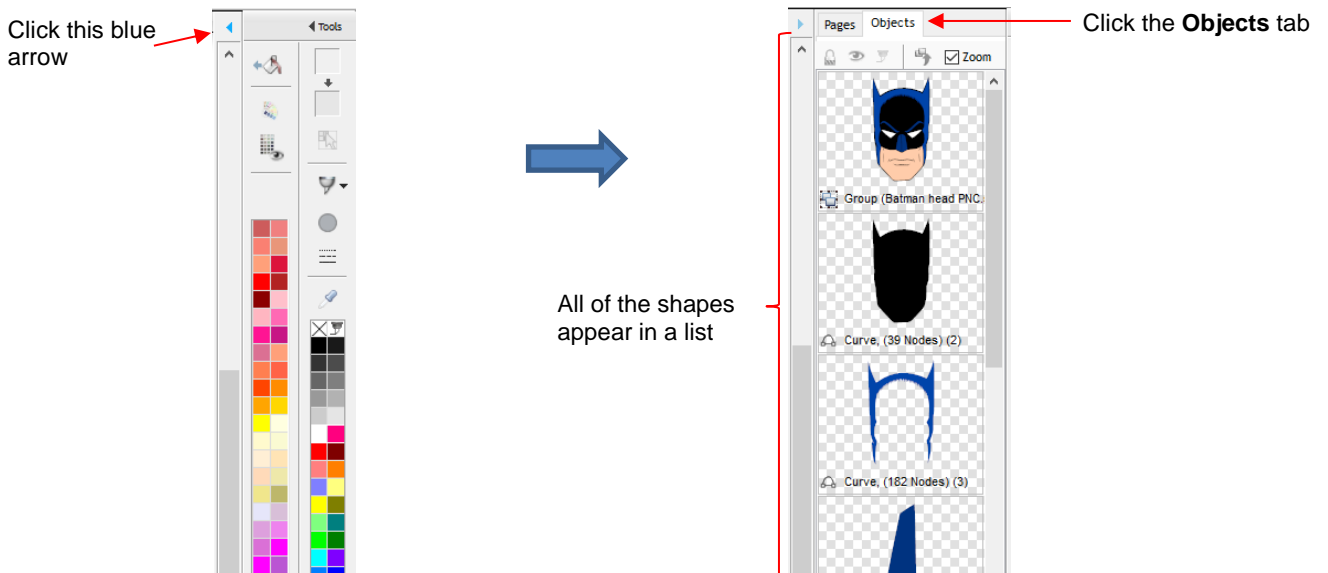

- From the **Objects** list, click on the shape which represents the contour cut line you wish to use. In this example, it is the black shadow layer:

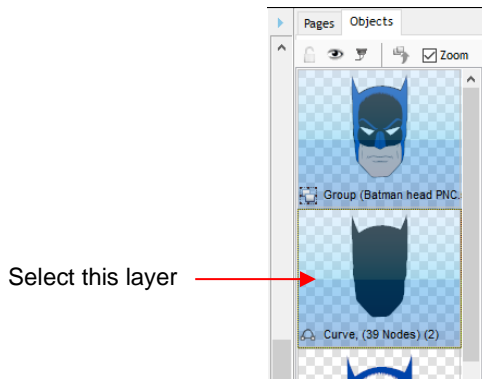

- With that layer selected, go to **Edit>Duplicate**. A new layer will appear at the bottom at the **Objects** list and, thus, will now be arranged on top of the project:

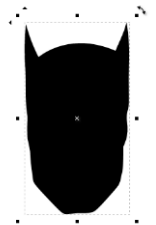

- This new layer will also be selected. To assign it as the contour cut, click on the **Custom Fill** icon that is located on the **Palette** and select **Cut Contour** from the drop-down menu:

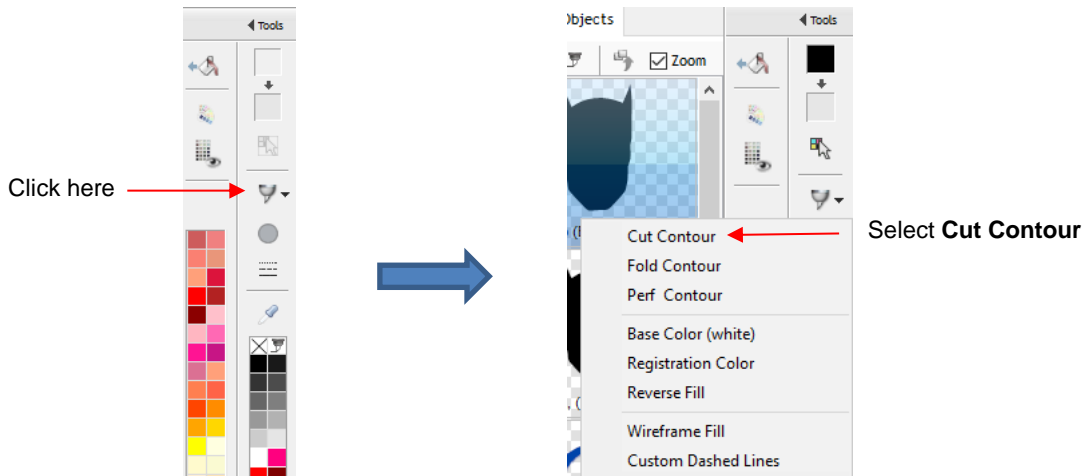

- This newly assigned contour cut layer is given an invisible fill color and will no longer appear on top of the imported project.

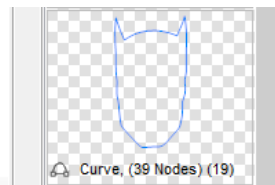

- If you now go to the **Contour Cut Wizard**, you can verify that this new cut layer exists on the **View Cut Only** tab:

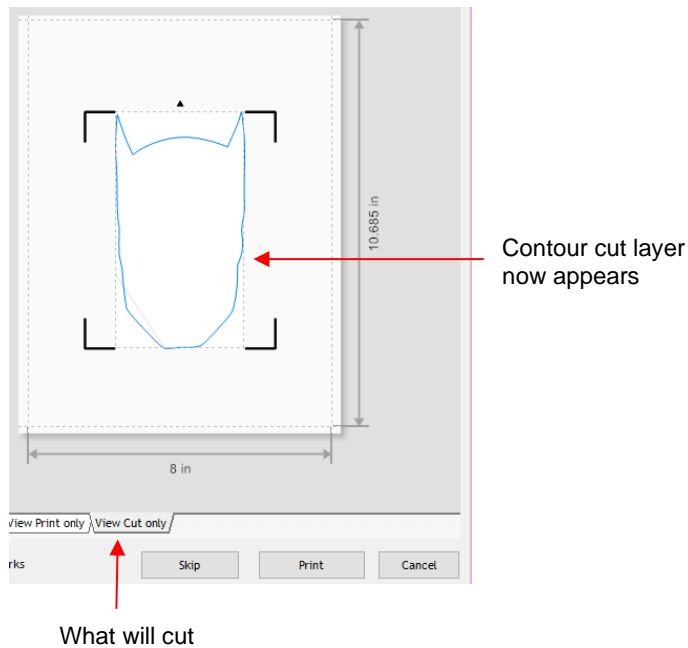

5.02.2 Contour Cut Which Is Offset from the Printed Design

- This section presents the method to be used when the contour cut is not one of the existing vector shapes. While this section accesses the **Create Cut-Contour** window from within the **Contour Cut Wizard** window, note that the same process can be applied by adding the contour from the main screen as was done in *Section 5.01* (i.e. select shape and go to **Contour Cutting>Create Cut Contour**).
- In the earlier screenshot, SignMaster recognizes there is no contour to cut on the **View Cut only** tab and offers the option to add one using the **Build** button below the preview.

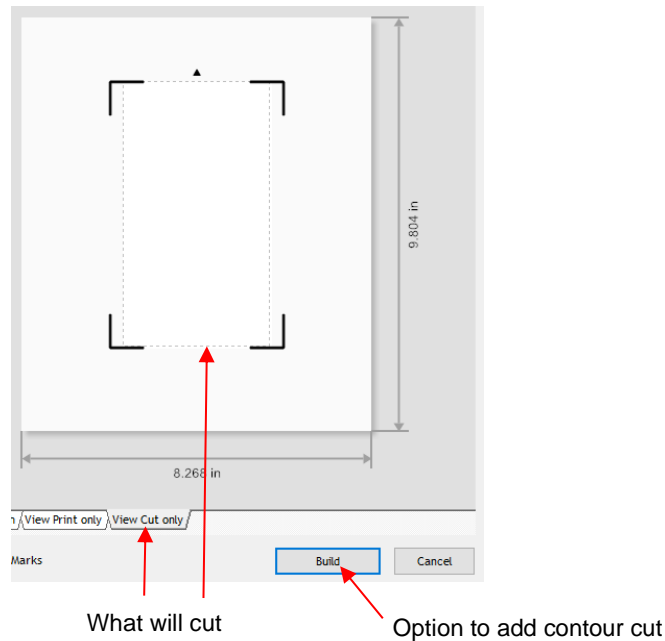

◇ Clicking on **Build** opens the **Create Cut-Contour** window:

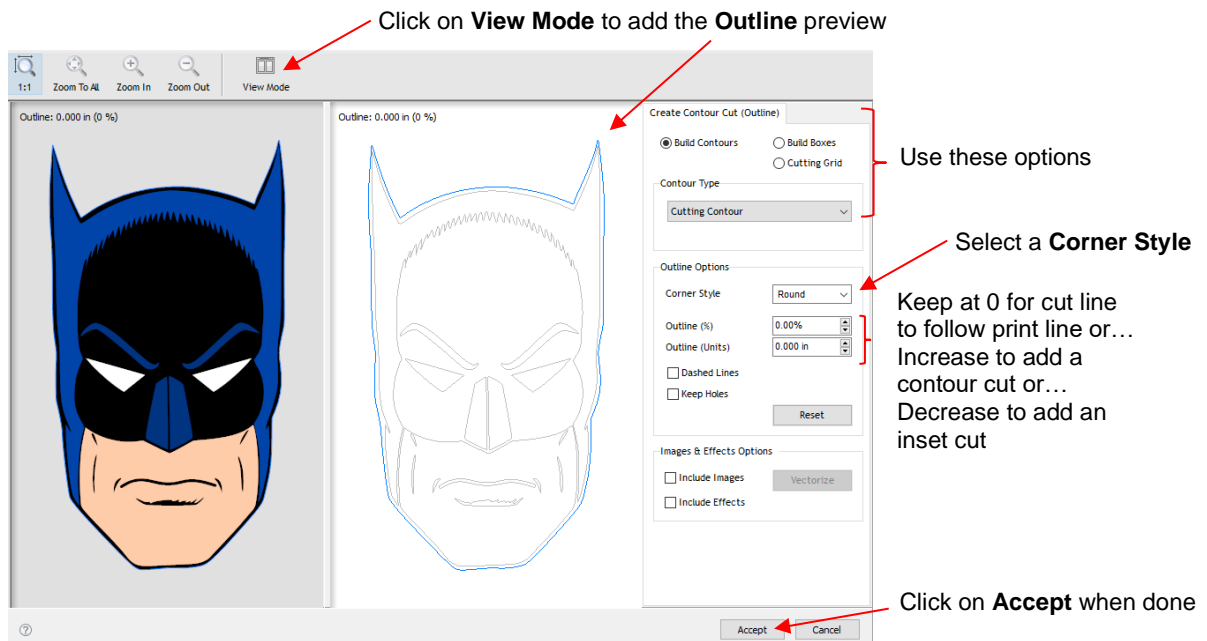

- **Corner Style:** Usually select either **Round** or **Sharp** depending on the nature of the original vector and your desired contour
- **Outline (%)** or **Outline (Units):** Enter either a percentage or the actual size for the outline. In the prior screenshot, leaving the **Outline** at 0 results in the contour being the same as the original outside vector line. This would result in the same contour cut as was created in the prior *Section 5.02.1*. For an outset cut around the printed image, increase **Outline** to the desired size. For inset or inline cut, decrease **Outline** slightly so that it's a negative number:

- **Outline** is set to 1/8 (0.125) inches:

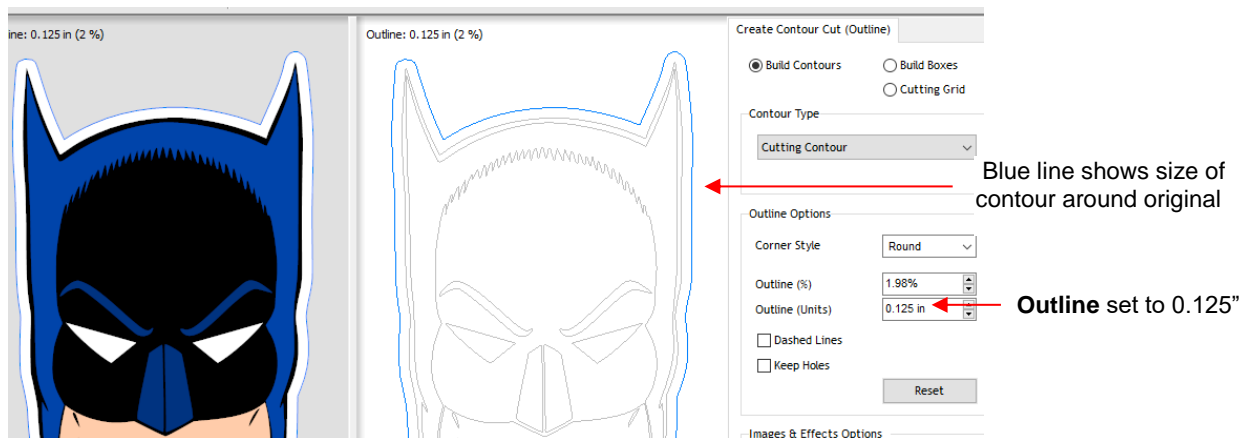

- **Inline** is set to -1/32 (0.03) inches:

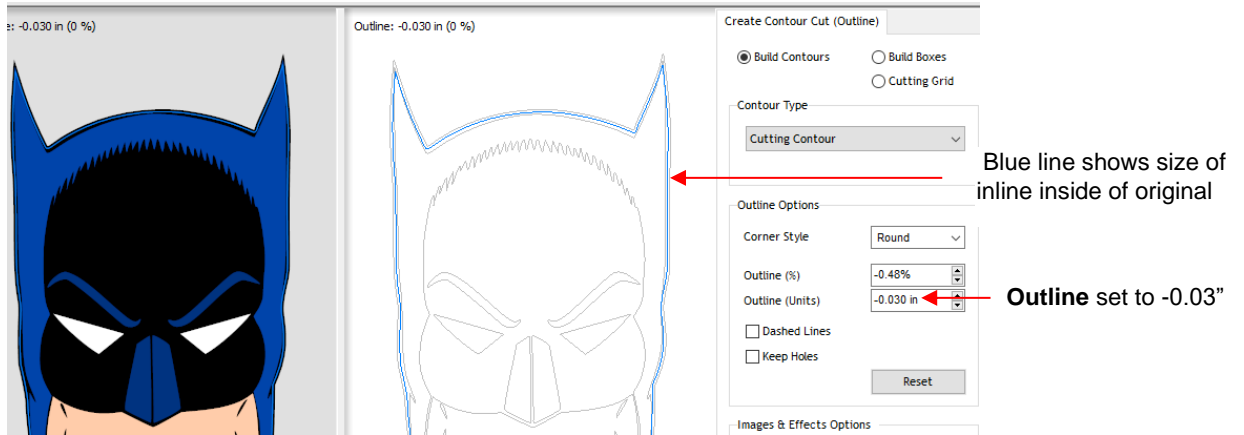

- ◇ After clicking on **Accept**, the **View Cut only** preview now indicates a cut path exists and you're ready to proceed:

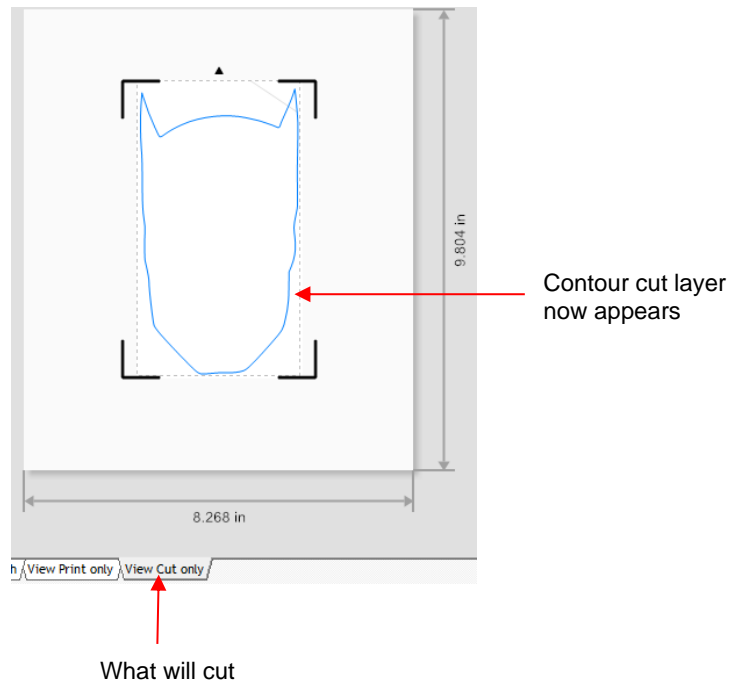

- Note that text is also a vector shape, thus the contour cut on a text object would be created the same way.
- Also note that there is a **Keep Holes** option in the **Create Cut-Contour** window which controls whether or not the contour is a solid outside cut or contains internal cuts following the shape of the vector:

- ◇ **Keep Holes** not marked:

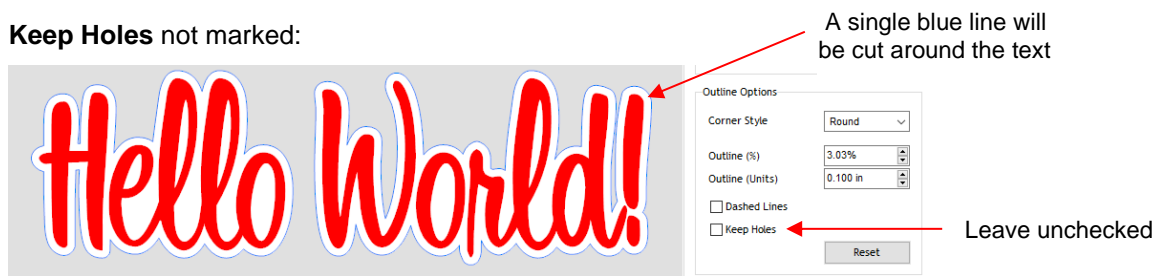

- ◇ **Keep Holes** marked:

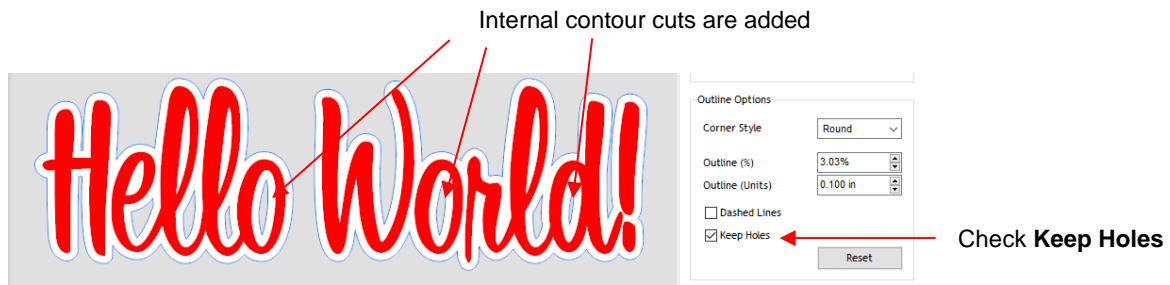

5.03 Engraving Fill

5.03.1 Engraving File Module and Settings

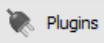
- If you wish to fill in a shape with a line pattern, SignMaster offers an **Engraving Module** which can be opened by clicking on the **Plugins** icon  and selecting **Engraving Module**.
- The following window opens and you will see your selected shape has already filled with lines:

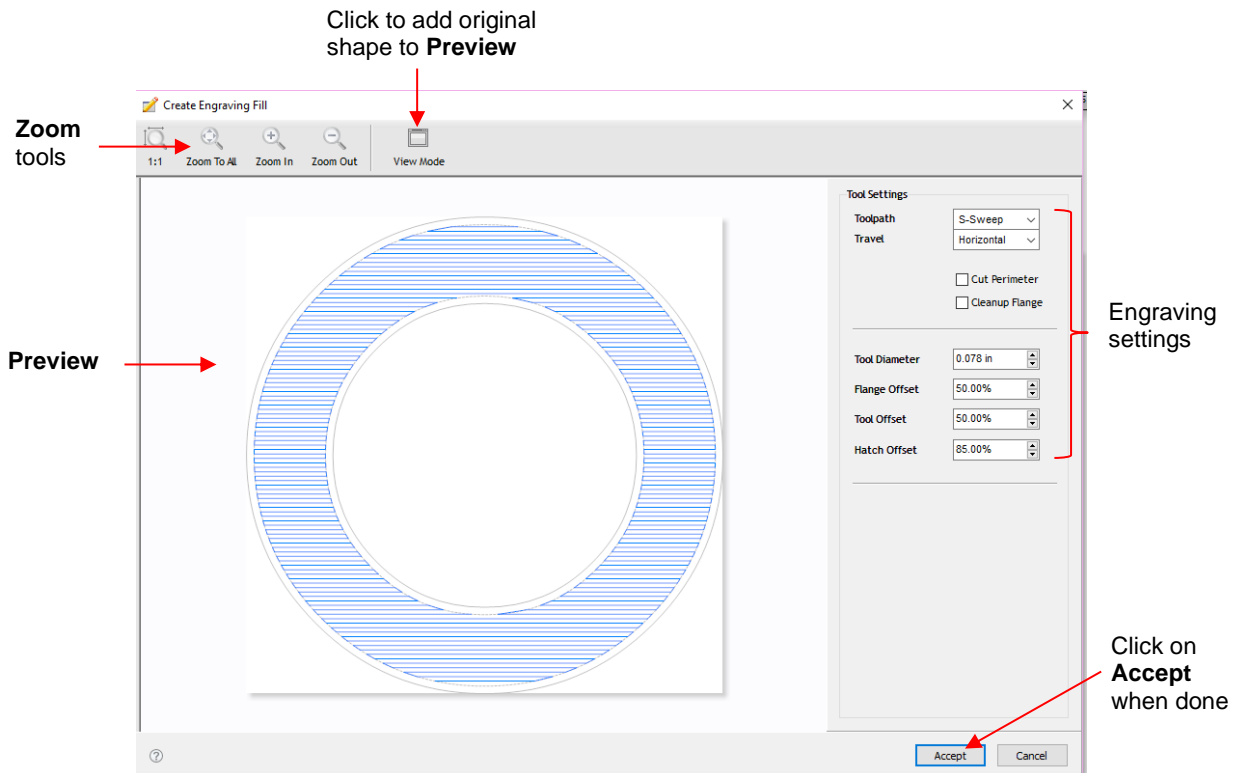

- ◇ In the top left corner are zooming tools. The **View Mode** icon can be toggled to add the original selected shape to the **Preview** window, if desired:

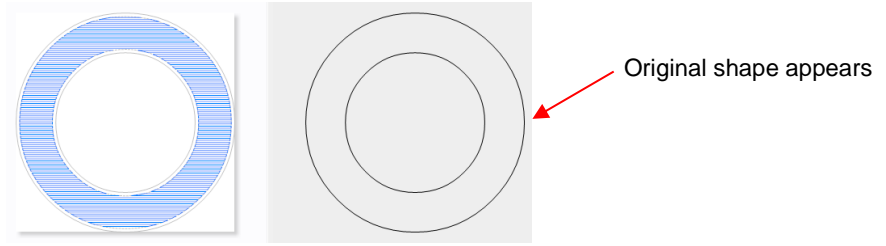

◇ **Toolpath:** There are four options in this menu:

- **None:** no fill pattern is created
- **S-Sweep:** a line fill pattern in which the tool stays down while filling the entire shape:

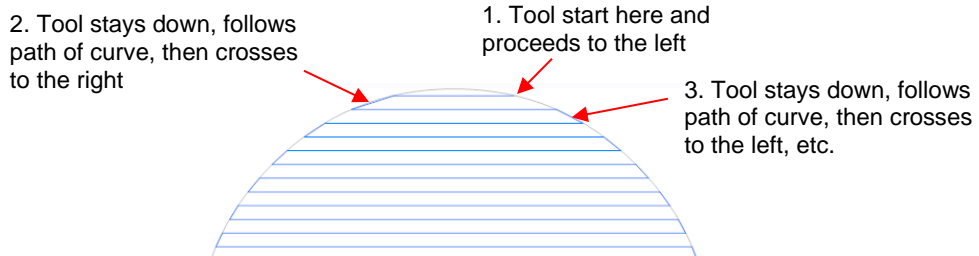

- **Line Fill:** a line fill pattern in which the tool raises at each side, moves a “row” down, and then proceeds to the other side:

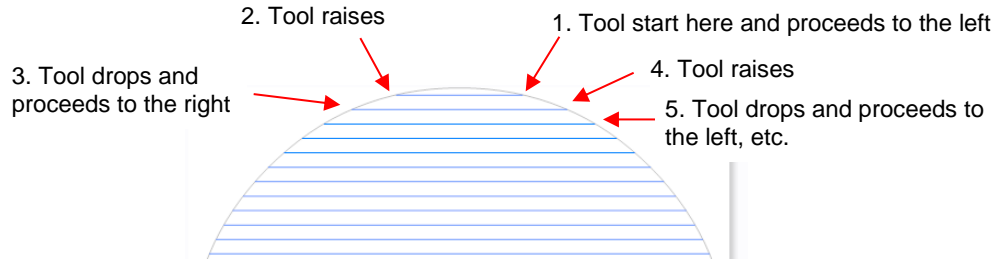

- **Island Fill:** a progressive inset pattern based on the original shape; the tool drops to complete a path, raises, moves to the next path, drops to complete that path, etc.. Some shapes work better than others with an **Island Fill**:

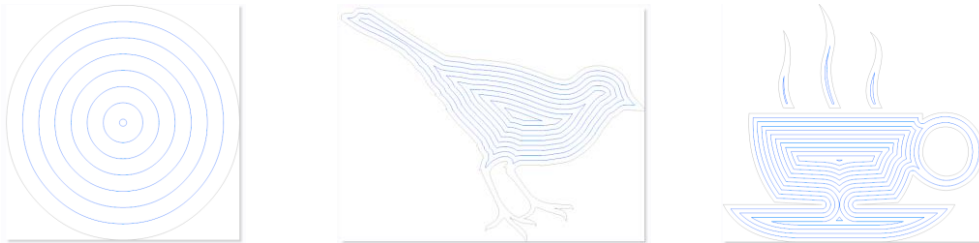

◇ **Travel:** four angles from which to choose, applying only to **S-Sweep** or **Line Fill** patterns:



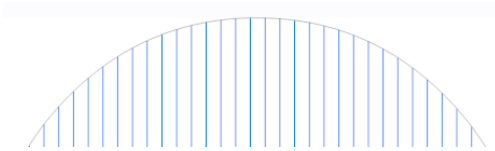

Vertical

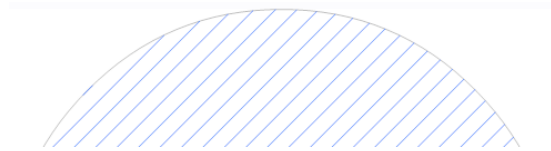

Diagonal - Down

- ◇ **Cut Perimeter:** turn on this option if you want the original shape to be engraved as well:

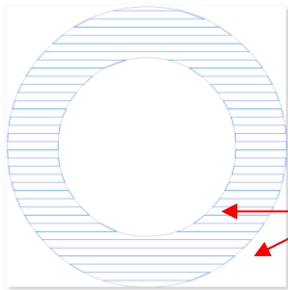

Cut Perimeter: not checked

Perimeter of shape is light, indicating it will NOT be engraved

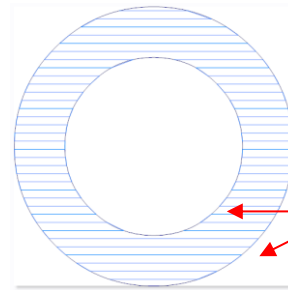

Cut Perimeter: checked

Perimeter of shape is dark, indicating it will also be engraved

- ◇ **Cleanup Flange:** turn on this option to have an engraving of the original shape, but along the edges of the engraving lines. Note that there is also a **Flange Offset** setting which is a percentage distance from the original shape to the engraving lines. These settings are typically not needed with small diameter tools, like the Skycut engraver, so you most likely won't have a need to activate **Cleanup Flange**.
- ◇ **Tool Diameter:** The size of the engraving tip, pen nib, embossing tip, or other tool. For the Skycut engraver, use 0.004 inches or 0.1 mm.
- ◇ **Tool Offset:** This setting is the distance between the engraving lines as a percentage of the **Tool Diameter**. Lowering this setting will decrease the spacing between the lines:

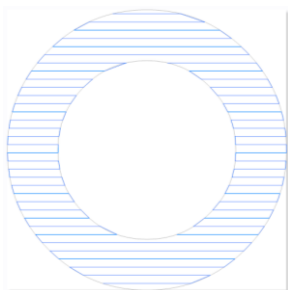

Tool Offset: 34%

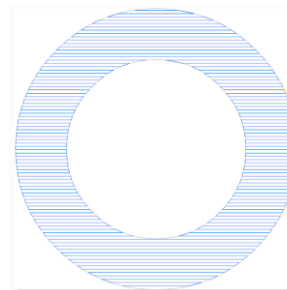

Tool Offset: 15%

Engraving lines are much closer together

- ◇ **Hatch Offset:** This setting controls the distance from the engraving fill to the outside perimeter of the original shape, again as a percentage of the tool diameter. A setting of 0% will extend the pattern all the way to the perimeter:

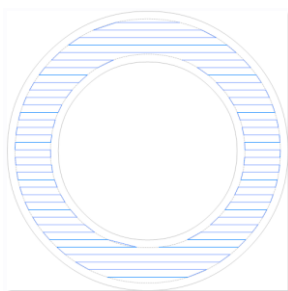

Hatch Offset: 35%



Hatch Offset: 25%

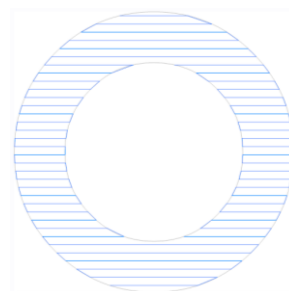

Hatch Offset: 0%

5.03.2 Inside Fills Versus Outside Fills

- In certain situations, you might want to reverse the parts of a design that are filled. To do this, add any outside shape to the design, such as a rectangle, an oval, a heart, etc. The engraving fill automatically fills the space between this new outside shape and the original design.
 - ◇ For example, if three stars are sent to the **Engraving Module**, then they will immediately fill with lines such as this:



- ◇ If shapes are added around these stars, then the fill pattern reverses to fill the space between the original shapes and the new outside shapes:

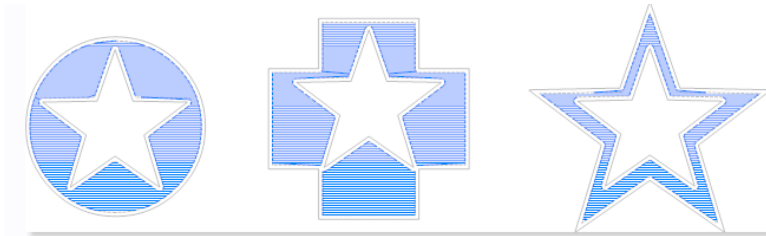

- ◇ If another shape is added to the outside of these shapes (a large rectangle is added to encompass the three shapes), then the fill will revert back to the original stars and a line fill is added between the rectangle and the outside shapes that were added:

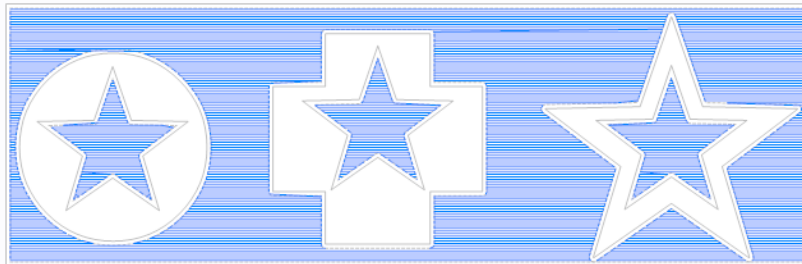

- If, for some reason, you want the outside shape present but NOT have the area between the two shapes filled, then only select the initial shapes (i.e. the stars) to send to the **Engraving Module**.

Appendix A Troubleshooting FAQ's

A1 Communication Issues

I cannot get the Skycut to power on.

- Make sure the power cable is securely plugged into the Skycut's port on the left side and securely plugged into a wall socket or a power strip.
 - If it still fails, check the wall socket or power strip with another device, such as a table lamp.
 - If you still cannot get the Skycut powered on, contact your dealer.
-

I cannot get Wi-Fi to work with my Skycut.

- Set the Skycut close to the router when performing the initial setup presented in *Section 1.12.2*. After establishing communication, you can test how far the Skycut can be located from your router.
- In SignMaster's **Vinyl Spooler** window, under the **Connection** tab, make sure you have selected **TCP** and entered the same **IP address** you selected during setup on the Skycut's control panel:

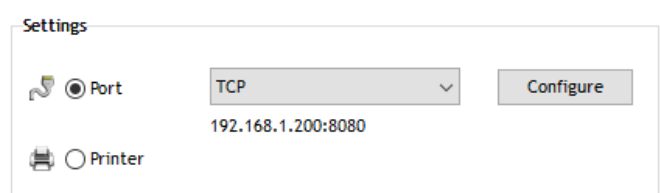

- Make sure your computer is connected to the same router as your Skycut.
 - Verify that SignMaster is the selected software on the control panel under **Set>Sys Information**.
-

I cannot get USB to work with my Skycut.

- Unplug/replug the USB cable at both the computer and at the Skycut.
- In SignMaster's **Vinyl Spooler** window, under the **Connection** tab, make sure you have **Direct USB Port** selected under **Port Type** and the **Status** says **Device Connected**. If not, repeat the instructions in *Section 1.12.1*.

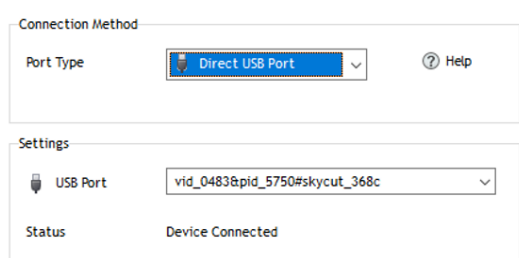

- Try a different USB port on your computer.
 - Verify that SignMaster is the selected software on the control panel under **Set>Sys Information**.
 - Try a different USB cable.
-

*I had to cancel a cut. Now my Skycut is no longer responding when I click on **Cut Now**.*

- There is a reset button on the right side of the Skycut D. Use a pen or pencil to press and hold for one second. You should hear a beep.
-

A2 Operating Issues

The control panel isn't responding very well.

- Press control panel icons with your finger and not your fingernail. You can also use a black rubber stylus.
 - Make sure the control panel is clean.
-

My mat is rotating when the Skycut starts to cut!

- Two pinch wheels need to be gripping the mat. Move the mat either left or right so that it is under two outer pinch wheels and the pinch wheels are aligned under white arrows. Refer to *Section 1.09*.
 - Make sure you are not trying to force the blade to cut too deeply and/or too quickly through a thick/dense material like chipboard or craft plastic. Slow the speed, decrease the **Force**, and add more passes.
-

My vinyl isn't feeding evenly while cutting. It starts bunching up on the inside of the end cap.

- Even if you feel the vinyl is aligned properly at the start of the cut, a slight "out of alignment" error will become more pronounced with a long cut. When you first drop the pinch wheels, use the arrow keys to feed the vinyl for the length of the cut to make sure it is feeding straight. If not, then about half-way through the length of the vinyl needed, lift the pinch wheels and realign the vinyl. Continue testing the alignment until you can verify that the vinyl is sufficiently aligned for the entirety of your project.
-

The pinch rollers are not tight enough to hold the vinyl I'm cutting. The vinyl is slipping and rotating when I start the cut.

- The pinch wheels need to be over grit shafts (the dark gray rough areas along the revolving shaft. The white rectangles will help you align the pinch wheels in correct locations. Also, use outside locations versus having, say, one pinch on the far right of the vinyl and a second pinch wheel only in the middle.
-

I hear a terrible stuttering sound when trying to cut chipboard (or other thick dense material).

- That can be a symptom of forcing the blade to cut too deeply and/or too quickly through the chipboard. Slow the speed, decrease the **Force**, and add more passes.
-

I'm trying to do a PNC application and the camera can't read the first reg mark. The light turns red and the Skycut starts beeping.

- Make sure the reg mark on the printout is at least 3 inches from the right end cap. Otherwise there isn't enough room for the camera to move to the right to take the photo.

I'm trying to do a PNC application. The camera reads the first mark and sometimes the second but not the third.

- Most likely you are not printing at 100% or you have activated **Borderless** printing in your printer properties window. Please refer to this document:

<https://tinyurl.com/b36hfc7>

I'm trying to do a PNC application and the camera can't read the marks.

- Make sure you have calibrated the Skycut's camera. The procedure is covered in *Section 3.03*.
- On the control panel, go to **Set>Camera** and press **Set**. Make sure the **Auto PNC** option is marked.
- If using the cutting mat, make sure the printout is aligned fairly straight on the cutting mat and the mat is fairly straight in the cutter.
- Make sure the blade holder is over the lower right registration mark when starting the cut.
- Are the registration marks printed dark with no streaking or missing ink?
- Did you make any changes in the **Contour Cutting Wizard** after printing and before trying to cut?

The Skycut stopped during a cut.

- If the Skycut stops with the head over on the left side of the cutter, you have most likely exceeded the cutting range. Several things to consider:
 - ◇ Check the width (**W**) of your project (or the height **H** if in **Landscape** mode). It cannot exceed 21.95" when cutting with the left head.
 - ◇ Check how far you are moving the head to the left when setting the origin. If your project is 21" and you moved the head more than 1" to the left, you will send the cut out of range and the cutter will stop.
- If the Skycut stops and the head is not located near the left side:
 - ◇ Make sure it's not a communication issue.
 - ◇ You may have exceeded a buffer limit. Try reducing the number of nodes. Select the shapes and go to **Curves>Node Editing>Reduce Nodes (Object)**.

I have sent a project that is supposed to use the right side for scoring and the left side for cutting. Everything is set correctly in the software but the left side is used for both the scoring and the cutting.

- On the Skycut's main control panel screen, make sure that **Use Double Head** is selected.

A3 Cutting/Drawing Issues

My shapes are drawing (cutting) off the material. What am I doing wrong?

- When setting the origin, make sure you are using the tip of the blade as the reference point and set the tip inside the corner of the material (not too close to an outside edge).
 - Verify that the preview window in SignMaster matches where you expect the shapes to cut as you view the material loaded into the Skycut itself.
-

When drawing with the test pen, I have extra lines being drawn.

- Make sure you raise the pen in the blade holder seat on the Skycut before tightening the screw. The blade holder seat needs to be able to drop the tool down when it reaches the spot to start the shape. Otherwise, the tool tip will be dragging across the material from the origin to where the shape will begin and then back to the origin at the end of the “cut”.
-

I'm drawing with a pen and there are bubbles at the corners.

- For perfect corners when using a pen, go to the **Send to be Cut** window and select **Pen Mode** so that **Blade Offset** is set to 0. You do not need an offset for pens (or other tools like embossers and engravers).

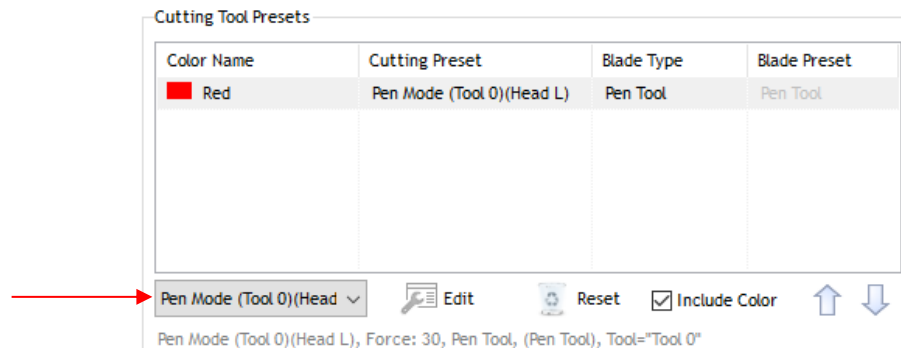

My cut started out fine but by the end of the cut, it's not cutting through the material.

- Make sure the blade holder housing doesn't have any bits of material inside of it.
 - Make sure the screw on the blade holder seat is hand-tight so that the blade holder isn't slipping upwards during the cut.
 - Make sure the cutting mat is clean and sticky and the material is pressed down completely, so that the material remains stabilized during the cut.
 - Make sure the blade isn't cutting too deep into the mat. This can sometimes cause the material to be pulled up and away from the mat as the blade releases from the plastic it is cutting.
 - Try increasing the Force by ~ 5 – 10.
-

My cut is clean in some places but not in others. Why am I not getting consistent cutting?

- Make sure your material is pressed firmly onto a clean and sticky mat (assuming you are cutting a material such as paper or cardstock).
 - Your material may require two passes if it's not homogenous or if it is heavily textured. Sometimes intricate shapes also cut better with two passes.
 - Also, if the material has been exposed to humidity, then it will become difficult to cut in one pass. You can dry both paper and cardstock using a blow dryer or in a very low-temperature oven.
 - If you are cutting vinyl without a cutting mat, check the cutting strip to make sure it is still in good condition.
-

I have the outside edges of my chipboard completely taped but I'm not getting clean cuts, even after lots of passes.

- Taping the edges prevents shifting of the chipboard but it's not enough for stabilizing. You need to thoroughly press the entire surface of the chipboard onto a clean and sticky mat. Using a brayer is recommended.
-

I am getting a lot of tearing in my cuts.

- A number of things can cause tearing so work through this check list:
 - ◇ Too much blade is exposed. If you see cut lines in your mat or the backing sheet, shorten the blade exposure. You should only be cutting through the material itself.
 - ◇ The blade is chipped. Try a different blade.
 - ◇ The paper is not adhered well to the mat. Make sure the mat is clean, sticky, and the paper is pressed smoothly and evenly on the surface.
 - ◇ You may be using too much **Force**. Try reducing it and doing test cuts.
 - ◇ You may have too many nodes in the shape. Select the shapes and go to **Curves>Node Editing>Reduce Nodes (Object)**.
 - ◇ The material itself may be subject to tearing, especially on intricate cuts. Also, if the cardstock has been exposed to humidity, then the moisture in the material can make it difficult to cut cleanly. You can dry paper and cardstock using a blow dryer or in a very low-temperature oven.
-

I'm cutting very small lettering and the letters are a bit distorted.

- Verify that you are using the correct **Blade Offset**.
 - Try slowing down the cut. Small lettering needs slower speed.
-

My cut shapes are not the same dimensions as what they are set to in SignMaster.

- Perform the calibration procedure shown in *Section 2.08*.
-

My shapes are not completely cutting out. They are still attached to the waste part of the material.

- Make sure you have set an appropriate **Overcut** setting.
 - Make sure the mat is not skewing during the cut. This can happen if even one of the pinch wheels is no longer centered under a white arrow. It can also happen if the speed and/or pressure is set too high.
-

My cardstock is not cutting all the way through. I have the blade all the way out and using the maximum force.

- Please refer to *Section 1.07.5*. It's important to only have as much blade exposed as is necessary to penetrate the cardstock. You may also need to raise the blade tip height (*Section 2.01.3*). Reduce your force back to suggested values for the material you are cutting and do a test cut.
 - Do not use more force than is needed. If the cardstock is cutting through about 90% of the cut, then increase **Passes**. Some cardstocks do better with a second pass at a lower force.
-

I calibrated the camera for print and cut but every cut is off by the same amount.

- The calibration can be tweaked using the procedure presented in *Section 3.06.1*
-

I calibrated the camera for print and cut and the cuts start off accurate but, by the end of the cut, there is a lot of error.

- This is called "drift" and can sometimes be corrected by slowing the speed and making sure the cuts aren't so deep that the blade is causing some drag to occur.
 - An alternative solution is to add intermediate registration marks. Refer to *Sections 3.08* and *3.09.2*.
-

Appendix B Original Camera Calibration

B1 Camera Calibration Procedure **Video**

- (1) Insert the test pen into the Skycut. Place a sheet of paper into the Skycut. You can use the cutting mat to hold the paper or insert the paper directly.
- (2) On the control panel, move the test pen over the sheet of paper.
- (3) Select **Speed/Force** and set **SPEED** to ~ 8 and **FORCE** to ~ 30. Click on **Test** to verify that a square is clearly drawn. If it is too faint, increase **FORCE** as needed and repeat.
- (4) Move the pen an inch or two away from the test so that there is room for the calibration shape to be drawn.
- (5) On the **Main Screen**, press **Set** and then **Camera**:

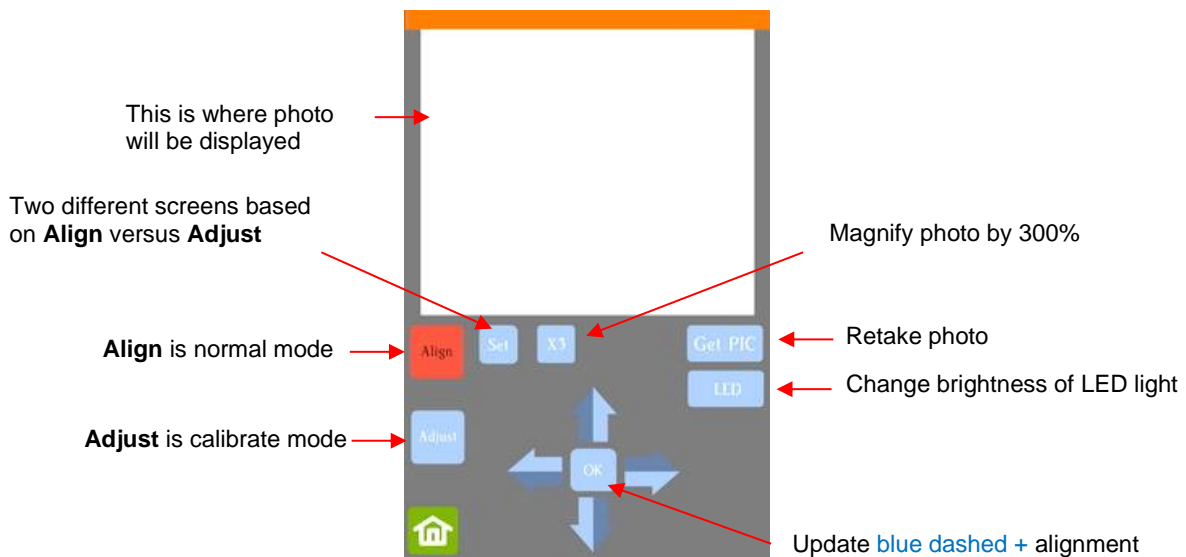

- (6) Press **Adjust** to switch to calibrate mode and a new **Start** button will appear in the lower right corner of the **Camera Screen**:

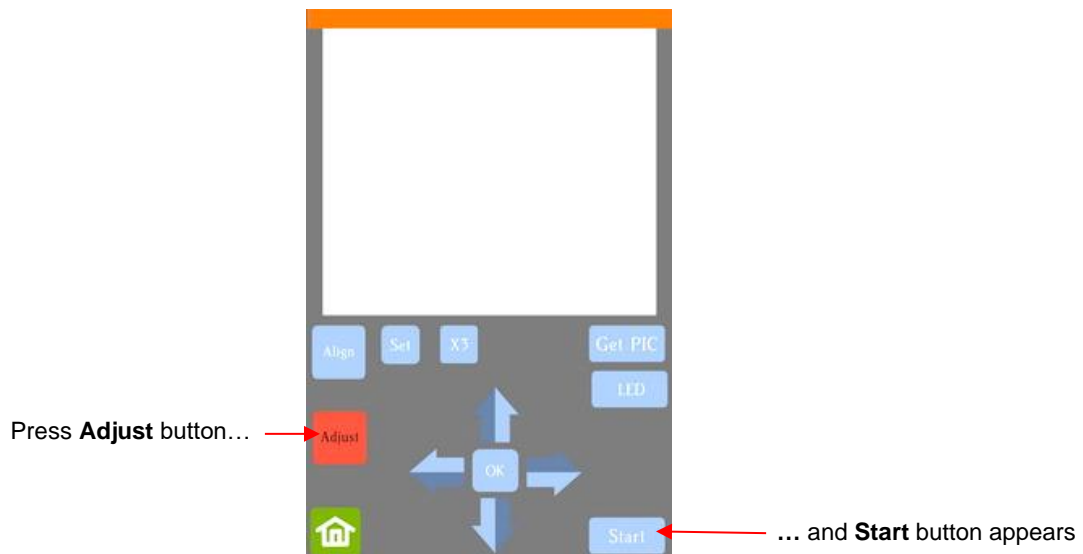

- (7) Press **Start**. The test shape, which is a square with a **+** inside, will be drawn on the paper and the camera will move over the test shape, take a photo, and display the photo on the control panel. If you cannot see the test shape clearly, press the LED button once so that it reads LED 50% and press the **Get PIC** button. You should see three items in the photo: the test shape that was drawn with the pen, a **red +**, and the **blue dashed +**:

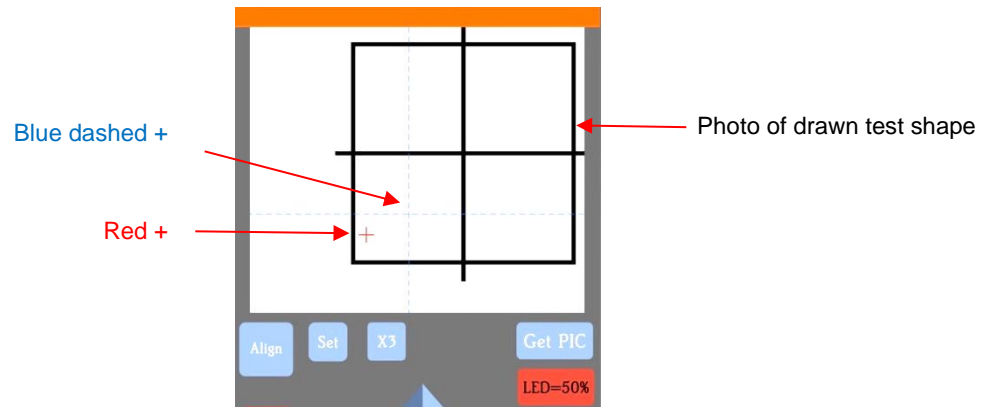

- (8) Tap your finger near the middle of the drawn test shape. This will move the **red +** to that location. Then press **OK**. A new photo will be taken:

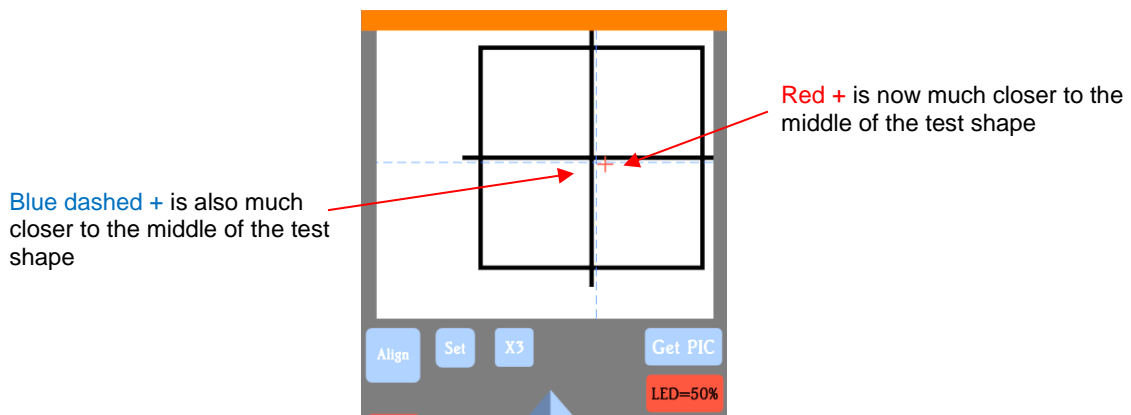

- (9) Press **X3** so that a magnified version appears:

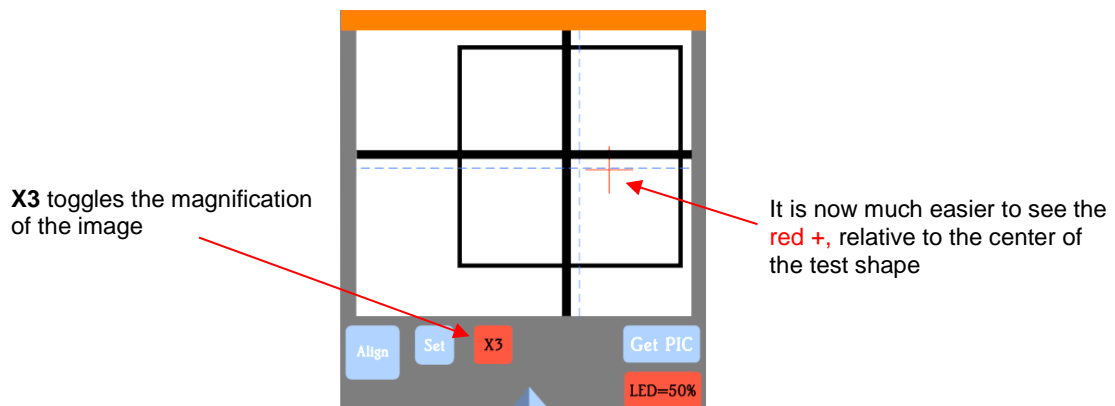

- (10) Use the arrows keys to move the center of the **red +** to the center of the test shape:

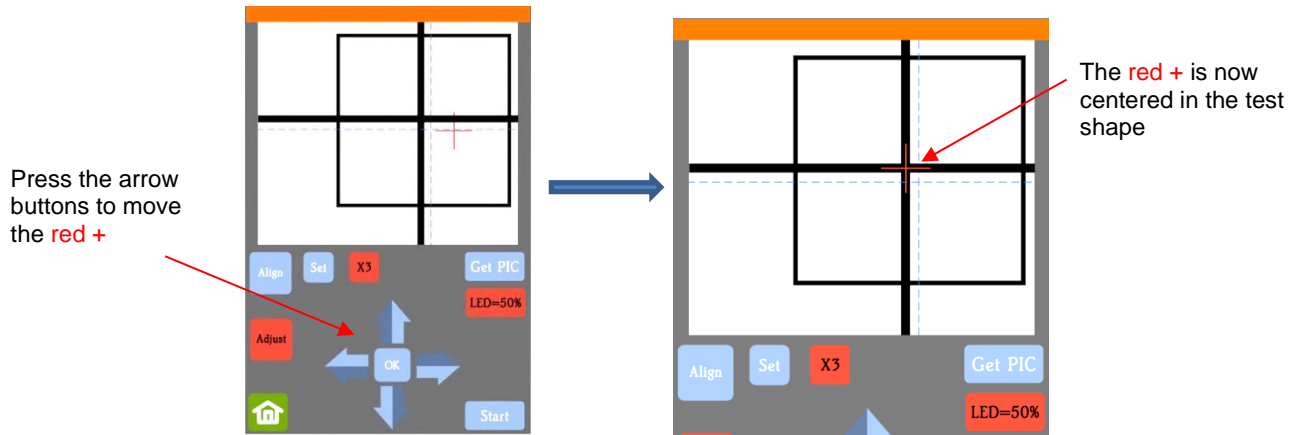

(11) Press **OK** and a new photo will be taken. The blue dashed + should now be more closely aligned with the center of the test shape:

IMPORTANT: the red + is intentionally moved away from the test shape with each new photo so that you can more easily see if the blue dashed + is centered.

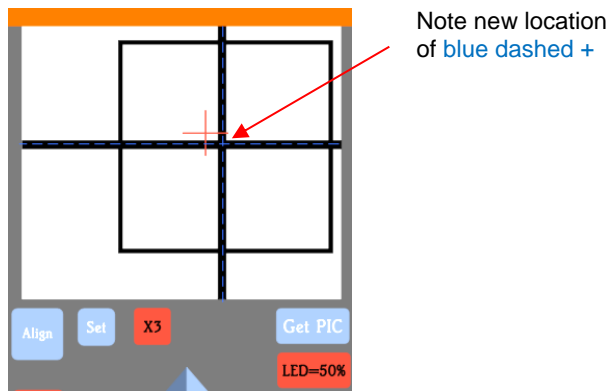

(12) If necessary, repeat *Steps 10 and 11* until the blue dashed + is near-perfectly centered in the test shape.

(13) Press **X3** to return to normal magnification. Click on the **Home** icon to return to the **Main Screen**. Your Skycut is now calibrated for print and cut (PNC) applications.

B2 Tweaking the Calibration Values

IMPORTANT: The following adjustment method only applies if you are on an older firmware version which required you to use the procedure in *Section D1* to calibrate the camera.

- If you find your print and cut results are slightly off in the same direction with each cut, you can adjust the values being used versus attempting to recalibrate from scratch.
- To do this, go back to an easy-to-cut material like copy paper and use a shape that has both horizontal and vertical lines. This makes it easier to know if you need to adjust in the **X** (left-to-right) direction or in the **Y** (up-and-down) direction. The arrow from SCAL's **Library** is a good choice since you can use the head of the arrow to make sure you put the printout onto the mat the same direction as in the software.
- After performing the print and cut, use a mm ruler to measure how far off the cut line is from the printed line. If you used an arrow, focus only on the horizontal and vertical lines, not the diagonal lines:

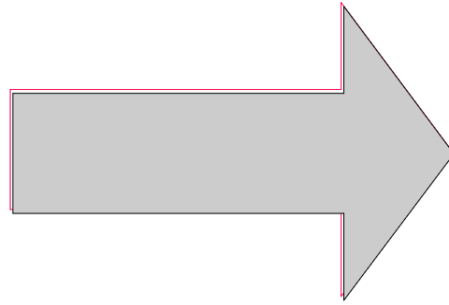

◇ In this example, let's say the red cut line is about 0.5 mm too high and about 0.3 mm too far to the left. Thus, you need the cut line to move down and to the right.

- On the control panel, change the **Units** to millimeters by going to **Set>General Settings** and choosing millimeters, as was shown in *Section 1.14.2*.
- Go to **Set>Camera** and click on **Adjust**. Then click on **Set** to open the **Adjustment** window:

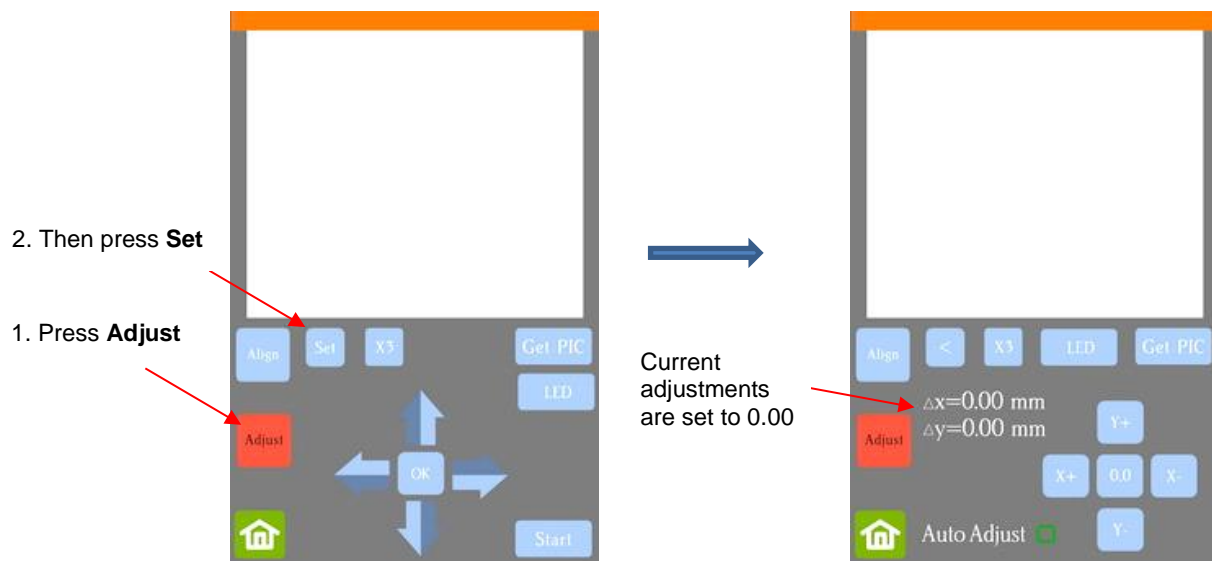

- One at a time adjust Δx and Δy by pressing the buttons in the direction you need the cut line to move.

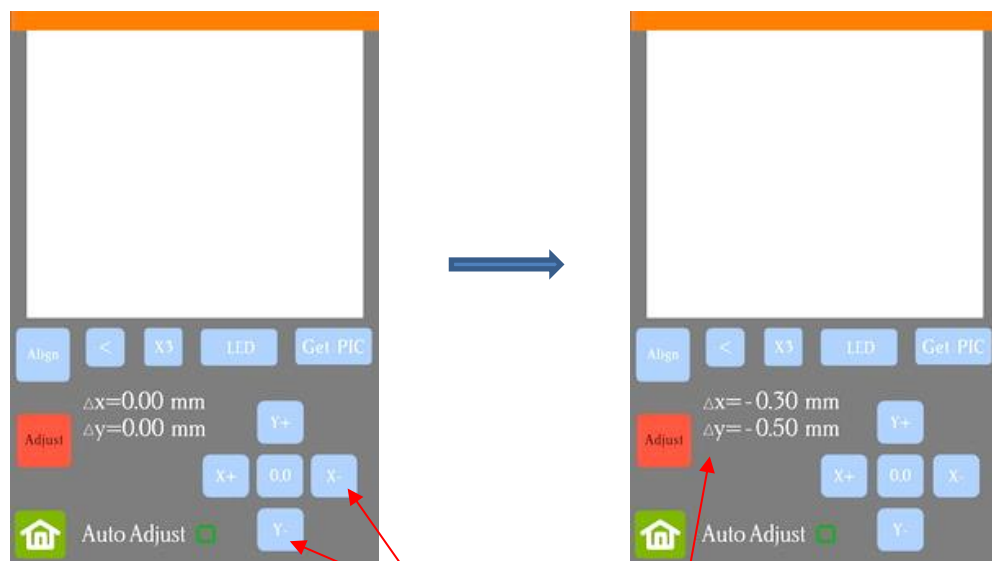

Use these buttons to adjust the Δx and Δy offsets to these

- Once the values are set, press the **Home** button to return to the **Main Screen**. Test again to verify the cut line is better aligned with the printed shape.
- ***Important:*** You can also adjust calibration numbers after a cut has begun! These adjustments will only apply for this particular cut but can be very useful in “saving a cut.” Refer to second part of *Section 3.07.3* for instructions.

B3 Dual Head Calibration

- In *Appendix D1* the camera calibration is presented showing how to make sure the blade holder is calibrated with the camera. A similar calibration is also needed to make sure the right and left blade holder seats are perfectly aligned with one another. This then allows you to do accurate draw-and-cut, score-and-cut, engrave-and-cut, and other combined tool applications.
- (1) On the control panel's **Main Screen**, make sure the **Use Double Head** option is selected. If you do not see any of these options, click on **Set>Advanced settings>System mode** and select **double**. Then, back on the **Main Screen**, the options should now be available:

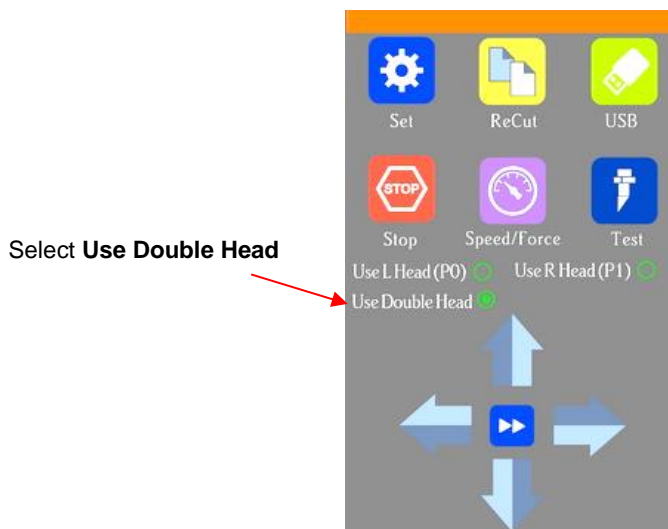

- (2) Insert a sheet of paper into the Skycut, either on the cutting mat or directly inserted. Load a test pen into both the left and right-side blade holder seats, making sure the pen nib is a little ways above the paper, as you did in *Section 1.13*. You can also use a stack of 35 Post It notes as presented in *Section 2.01.3*.
- (3) Select the **Speed/Force** function and make sure both sides are set to a suitable **Force** for drawing: ~ 30 – 40.
- (4) Make sure both pens are over the paper. On the **Main Screen**, select **Set>Camera** to open the camera calibration screen:

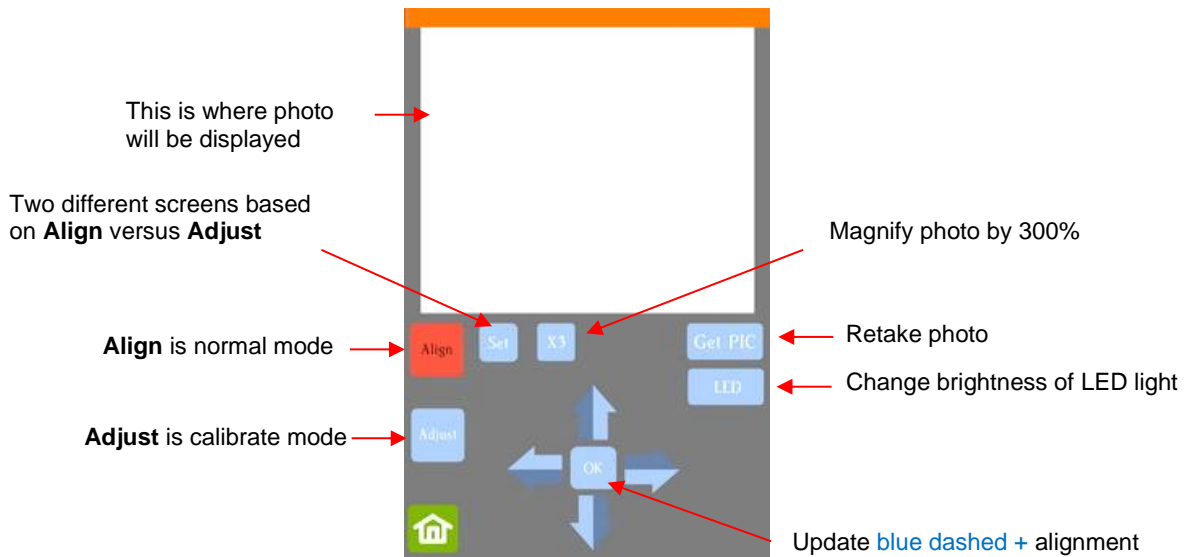

- (5) Press **Adjust** to switch to calibrate mode and a new **Start** button will appear in the lower right corner of the **Camera Screen**:

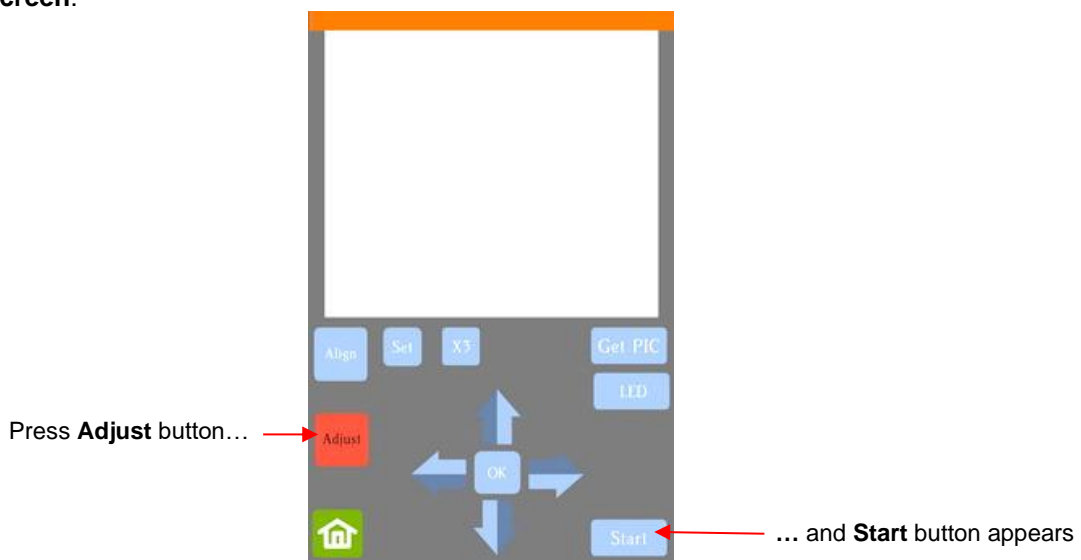

- (6) Press **Start**. A test shape, which is a square with a **+** inside, will be drawn by the right side pen on the paper and the camera will move over the test shape, take a photo, and display the photo on the control panel. If you cannot see the test shape clearly, press the LED button once so that it reads LED 50% and press the **Get PIC** button. You should see three items in the photo: the test shape that was drawn with the pen, a **red +**, and the **blue dashed +**:

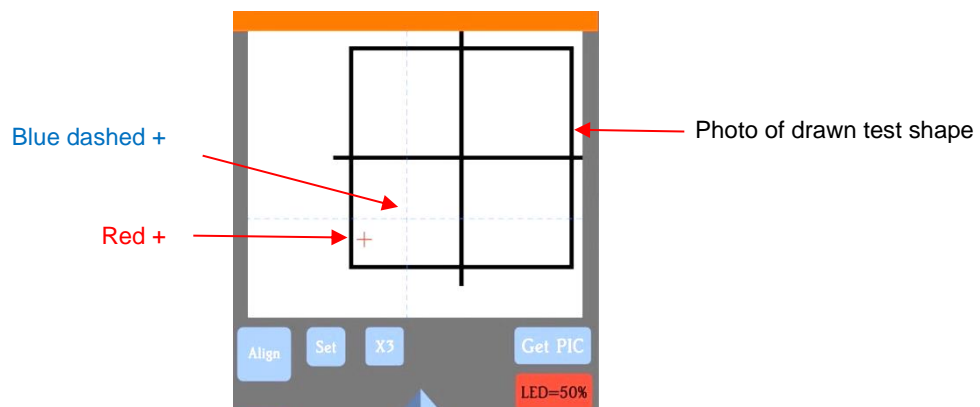

- (7) Tap your finger near the middle of the drawn test shape. This will move the red + to that location. Then press **OK**. A new photo will be taken:

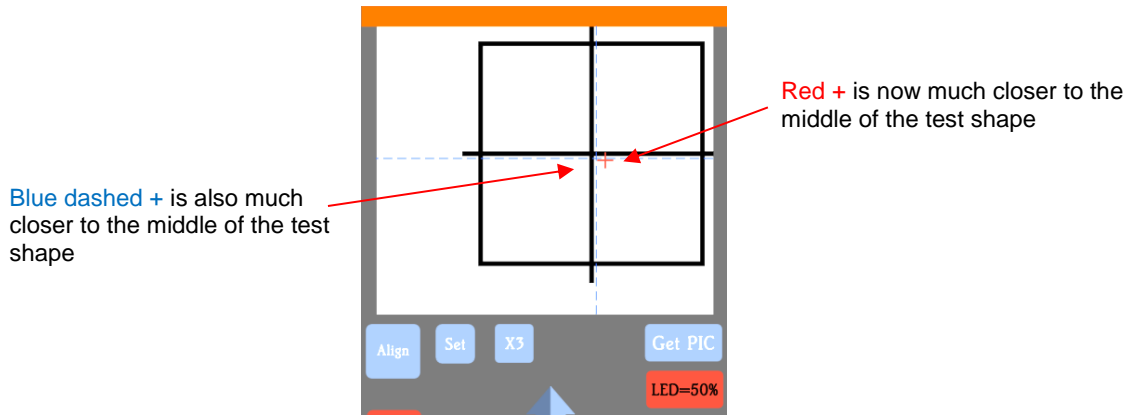

- (8) Press **X3** so that a magnified version appears:

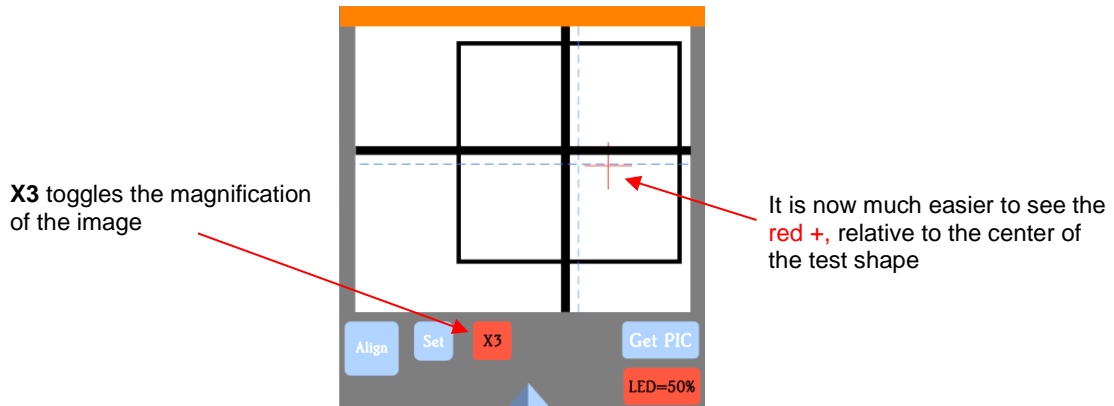

- (9) Use the arrows keys to move the center of the red + to the center of the test shape:

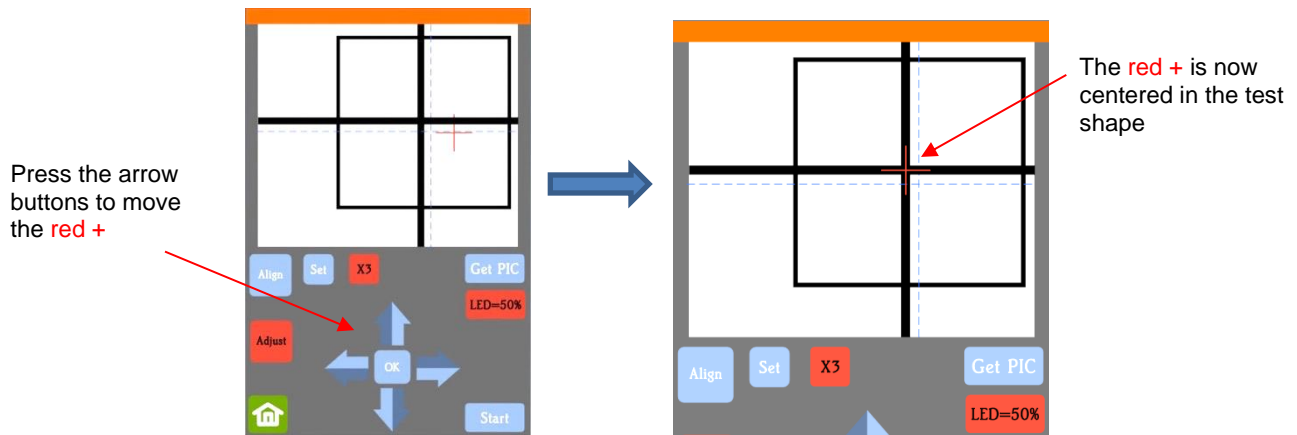

- (10) Press **OK** and a new photo will be taken. The blue dashed + should now be more closely aligned with the center of the test shape:

IMPORTANT: the red + is intentionally moved away from the test shape with each new photo so that you can more easily see if the blue dashed + is centered.

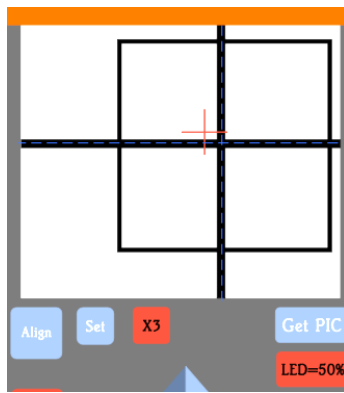

- (11) If necessary, repeat Steps (9) and (10) until the blue dashed + is near-perfectly centered in the test shape.
- (12) Now move the red + so that it is perfectly aligned with the center of the blue dashed +:

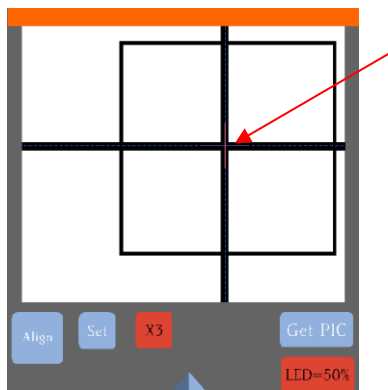

Move red + to align with center of blue dashed +

- (13) Press **OK** and the camera will move to the left side test square and will post an image. Repeat Steps (7) – (11). Once the blue dashed + is near-perfectly centered in the test shape, click on the **Home** icon to return to the **Main Screen**. Your Skycut is now calibrated for dual head applications.

Appendix C Activating Commands

- This section shows you how to activate commands in order to add certain functions to the control panel.
- Go to **Set>Advance settings>System Mode** and press the **cmd...** button:

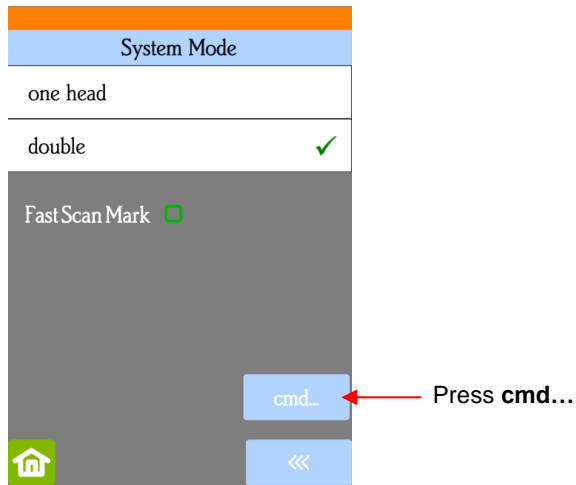

- The following screen opens. Press **Input**:

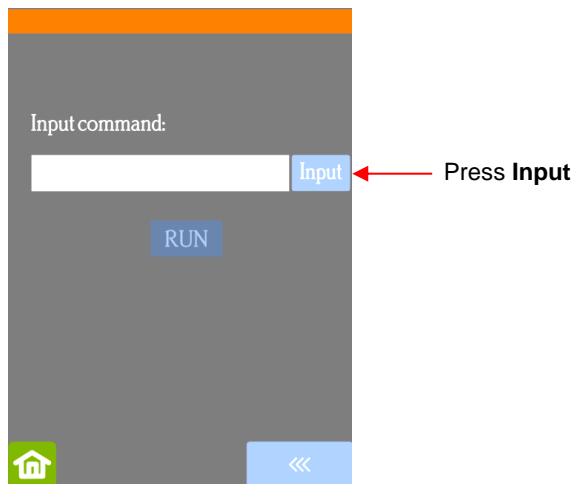

- The **Input** code is entered in the same way as you entered your **Network** password but since it's a 3-digit code, you'll begin by pressing the **123** button:

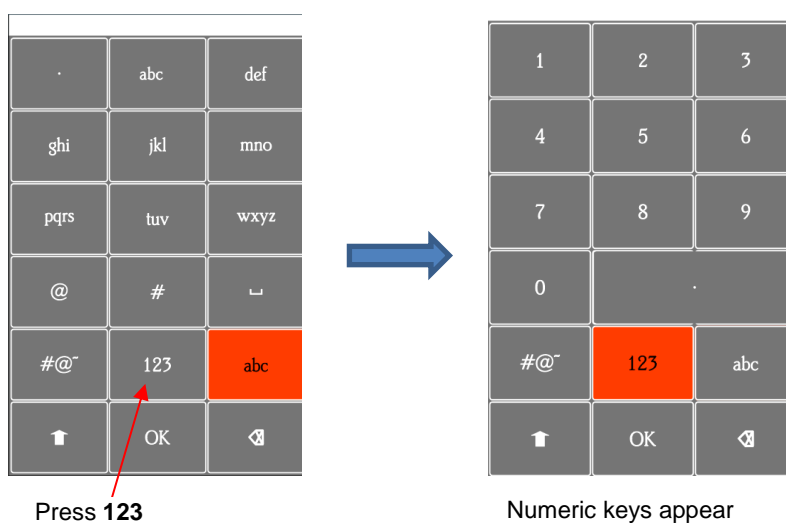

- Enter the required **Input** code according to the following:
 - ◇ 021: Activate **Mark Set**
 - ◇ 020: Deactivate **Mark Set**
 - ◇ 031: Activate **Passes Set**
 - ◇ 030: Deactivate **Passes Set**
- After entering the **Input** code you need, click on **OK** and the **Input** screen will return. The word **RUN** will now be highlighted and you can press it. The Skycut will beep once.

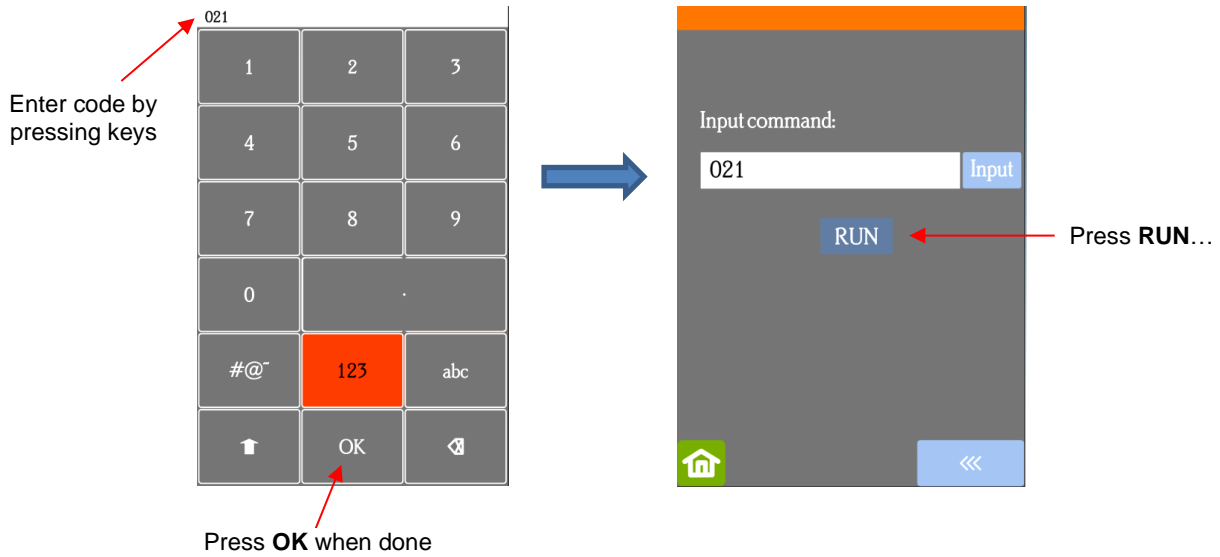

- Return to the main screen and press **USB**, the activated button will now appear:

