

# HEAT PRESS P1210/P1010/P0708

P1210, P1010 And P0708 Share This Manual

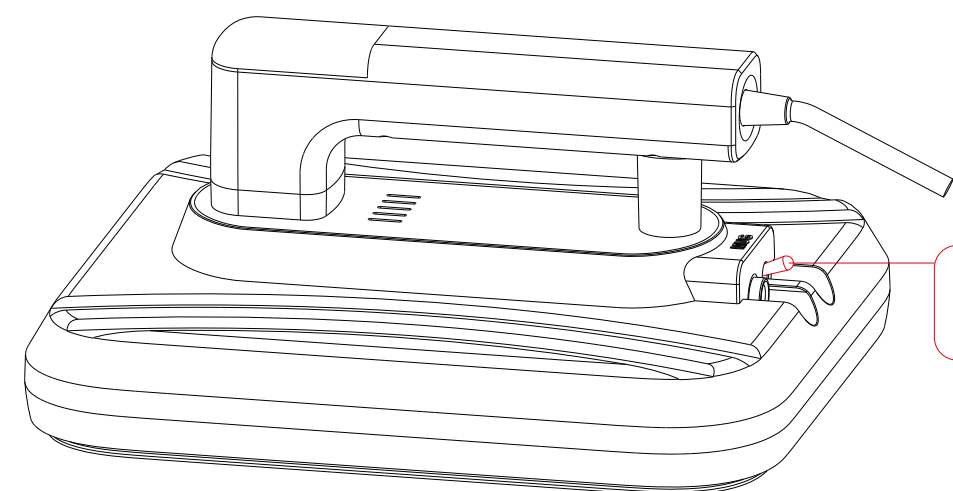

↑ Up, heat transfer caps and mugs  
↓ Down, thermal transfer clothing

## EN Start Here

⚠ Warnings must be followed carefully to avoid body injury.



Transfer Parameter(for reference)

T-Shirt ( Non-cotton )	T-Shirt ( PU flex film )	Aluminum Plate	Mug	Hat	Plate
200°C (392°F)60S	170°C (338°F)25S	180°C (356°F)80S	180°C (356°F)180S	200°C (392°F)40S	200°C (392°F)900S

Main parameters

Product Name	Portable Heat Press Machine	Rated voltage	220V~	110V~
Item No.	P1210/P1010/P0708	Rated frequency	50-60Hz	
Highest temperature	200°C 392°F	Rated power	1000W	800W
Longest time	999S	Length of the cable	2M	

Feature commentary

# 1

⊖ REDUCE

⊙ POWER BUTTON

⚙ TEMP/TIME

⊕ INCREASE

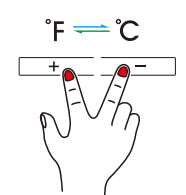

Note: Press (+/-) to switch Fahrenheit and Celsius

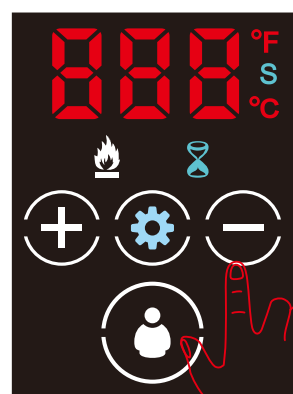

**POWER BUTTON**

3 seconds  
click once

1. Press and hold for 3 seconds, power on.  
2. Press and hold for another 3 seconds. Shutdown.  
3. Short click, Countdown starts.  
4. Short press again, Reset.

**REDUCE**

5 seconds

1. Long press for 5 seconds, Set automatic shutdown time

**SETUP**

click once  
5 seconds

1. Click it once, Set time. Click again, Set temperature.  
2. Long press for 5 seconds, ± 30°C temperature difference correction.

**VIBRATION PUMP SETTINGS**

1. Press the on-off key to enter the countdown state. Press the plus and minus keys to adjust the pump position

Temperature conversion  
°F = °C  
°C = °F

## MACHINE ACCESSORIES (The following are optional accessories)

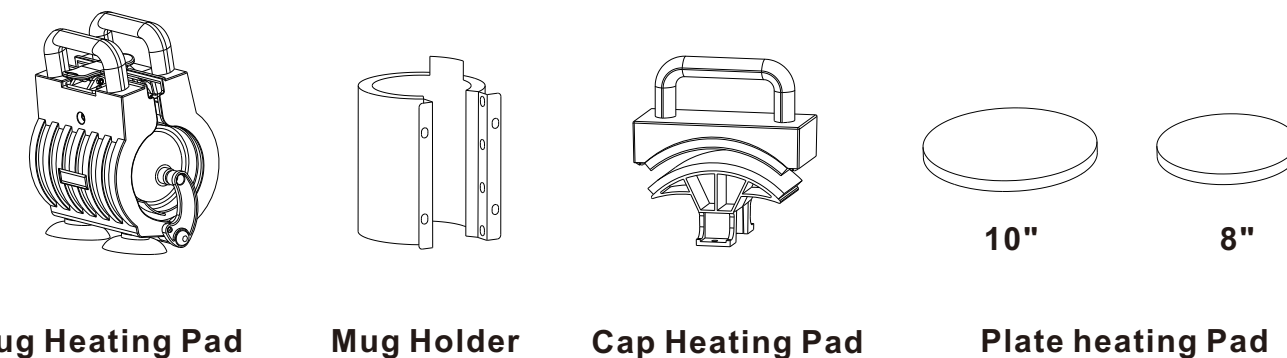

## CLOTHING HEAT TRANSFER

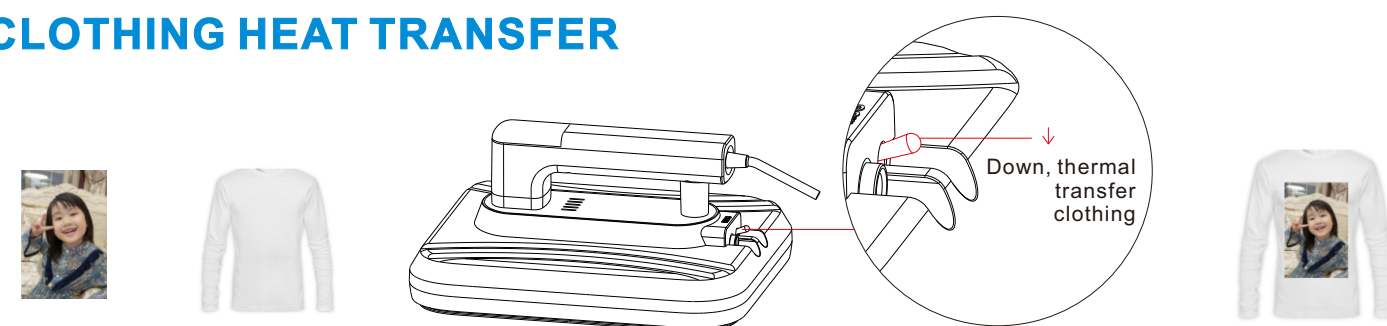

⚠ Accessories will vary according to the model customer selected, pictures for reference only.

## Accessories installation diagram

Please perform all operations after power off



### MUG HEAT TRANSFER

(This function is only suitable for P1210/ P1010)

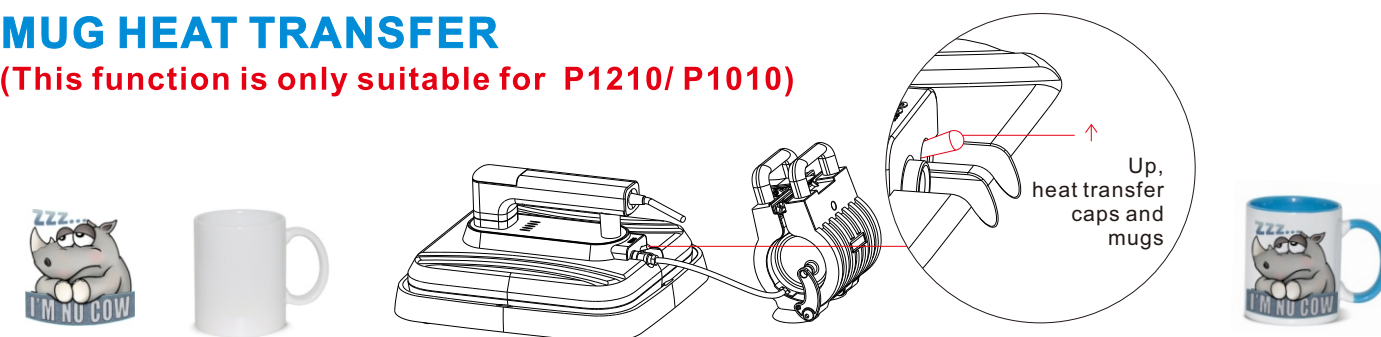

### CAP HEAT TRANSFER

(This function is only suitable for P1210/ P1010)

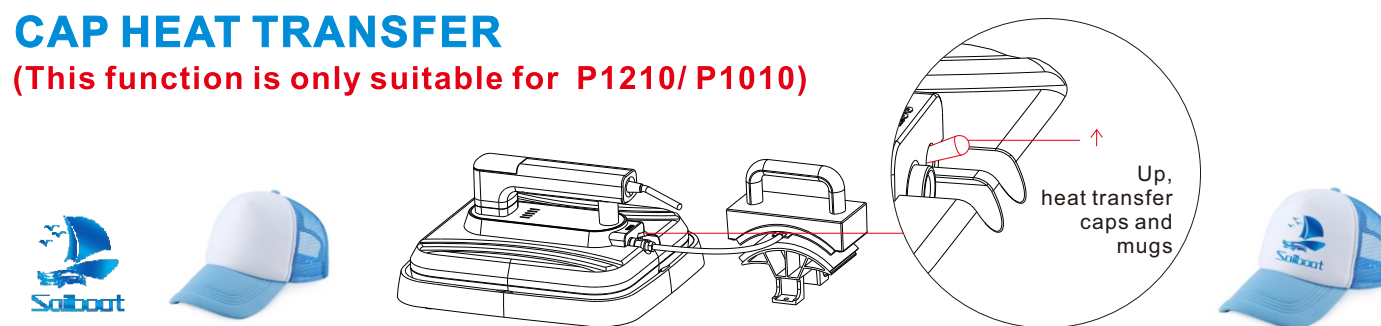

### THERMAL TRANSFER PLATE

(This function is only suitable for P1210/P1010)

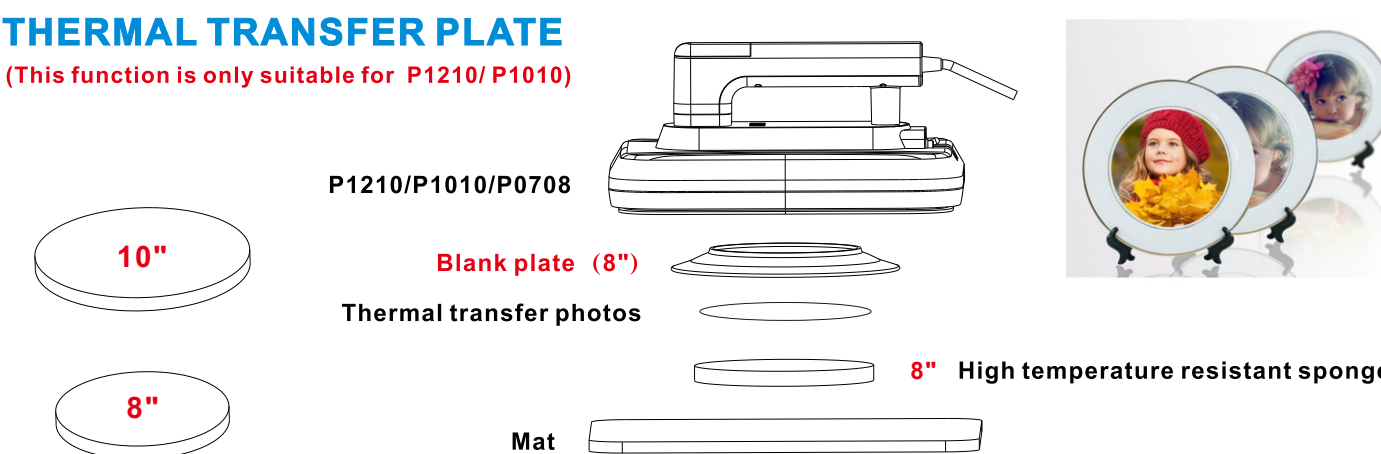

## Main spare parts

1. Silicone pad
2. Tray
3. Hot plate
4. Middle cover
5. Top cover
6. Touchpad
7. Handle
8. Transfer switch
9. Aviation connector

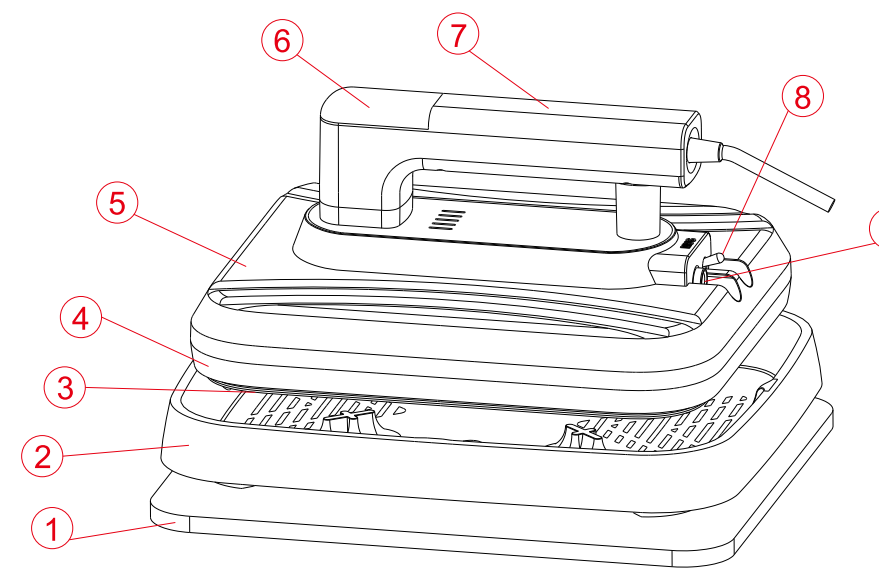

## Guarantee

The products are strictly based on the Consumer Protection Law of the People's Republic of China and the Product Quality Law of the People's Republic of China. The services are as follows:

Within 12 months, this product has the performance failure listed in the "Product Performance Failure Table". It is confirmed by SUNMETA and can be used for maintenance service free of charge. If out of validity, damage caused by force majeure, or human causes, the machine is not covered by the warranty, repair in charge.

**Safety instruction:** Before operating this unit, please read these instructions completely and save them

### Notice

- ⚠ Keep unplug when moving the machine
- ⚠ Keep unplug when installing accessories
- ⚠ Place on a flat and stable platform and operate under ventilated conditions
- ⚠ Wear special protective equipment when operating the machine

**Warning** Improper use may result in electric shock, fire, personal injury and other damage.

- ⊘ Do not use this machine in a hazardous location
- ⊘ Do not use when the machine is not working properly.
- ⊘ Do not allow children or adults who do not understand this manual to operate this machine.
- ⊘ Do not disassemble and repair this machine.
- ⊘ Do not use an unsuitable AC outlet.
- ⊘ Do not touch the heating plate when the machine heating.



## warranty content Product Performance Failure Table

Machine body	Parts of the machine itself (excluding main parts)	One year	Fault 1	The machine cannot be used normally according to the operating procedure
Main parts	Motherboard	One year	Fault 2	Heating plate not heating
	Heating plate	One year	Fault 3	Display error
	Vibration pump	<b>Silicone mat, no warranty</b>		

Circuit Board Wiring Method

# 2

## Electrical schematic diagram

