

Operation Manual

(Galaxy Twin Mug Pro GS-203T)

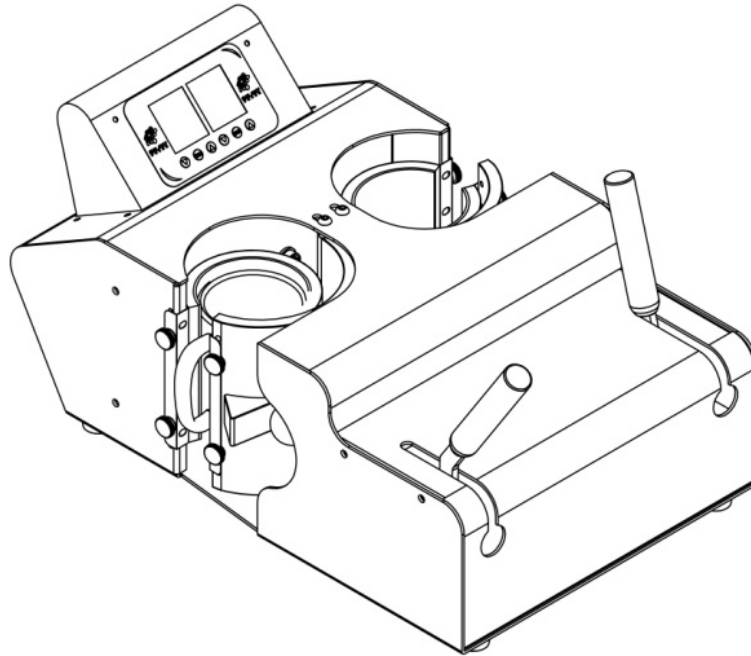

Technical Parameters

1. Model NO: Galaxy Twin Mug Pro (GS-203T)
2. Machine Size: L47*W23*H39cm
3. Mug Heater Size: Dia.6-7.5cm for 6oz,9oz,10oz etc mug (with machine*2pc)
Dia.7.5-9cm for 11oz,15oz etc mug(choosable)
For 12oz cone shape mug(choosable)
For 17oz cone shape mug(choosable)
4. Voltage: 220V/110V
5. Power: 300W+300W
6. Time Range: 0~999S
7. Maximum Temp: 200°C /392F
8. Packing Size: 54*36.5*29.5cm
9. Gross Weight: 12kg

Circuit Board Setting

1.Pre-printing Temperature Setting

Press “set” button first time, “temperature 1” flash, press “up” and “down” button to set, range from 0~160 C,0~320F. Display as below.

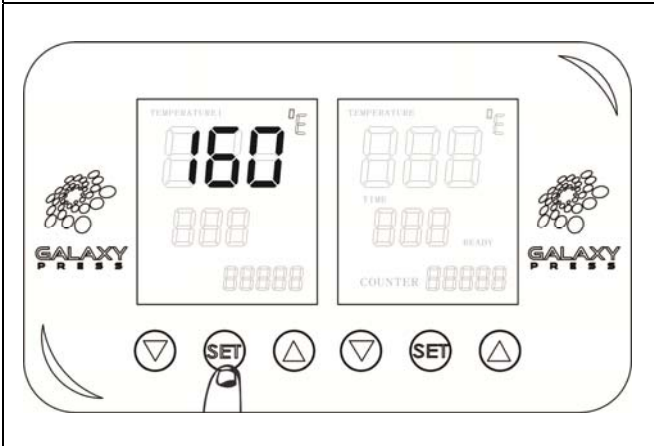

2.Printing Temperature Setting

Press “set” button second time, “temperature 2” flash, press “up” and “down” button to set, range from 0~200C,0~392F. Display as below

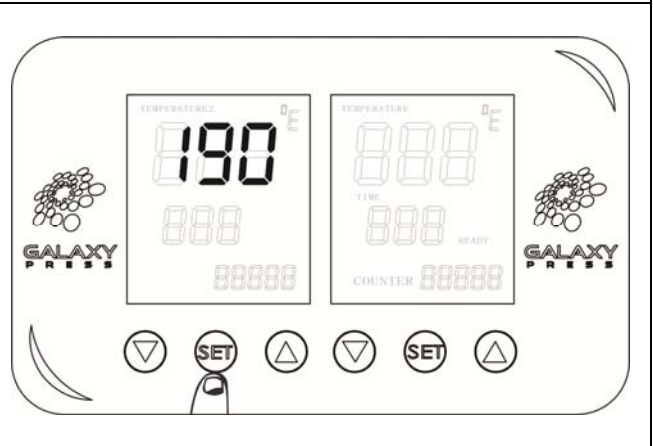

3.Time Setting

Press “set” button third time, “time” flash, press “up” and “down” button to set, range from 0~999S, Display as below

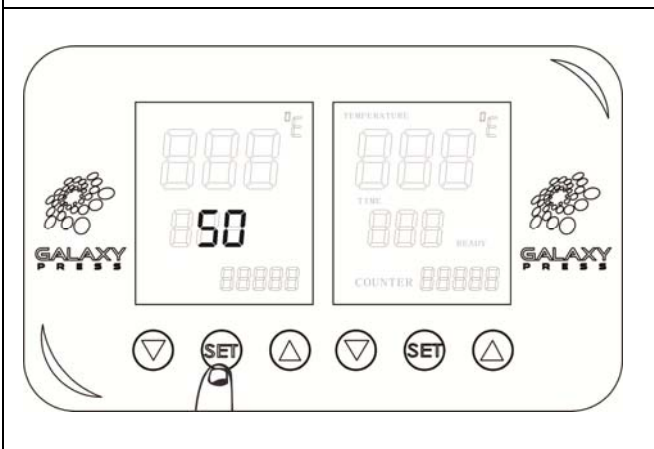

4. Counter Setting

Press “down” button for 4 seconds, “counter” flash, press “up” and “down” button to set, range from 0~99999, press “up” and “down” together to make zero clearing. Display as below.

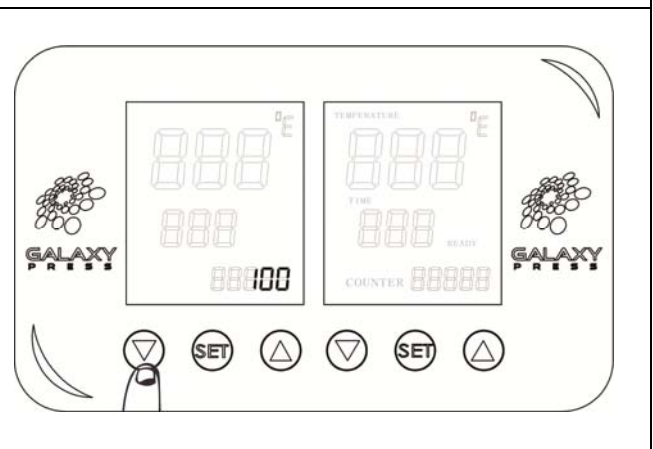

5.Switch Between F and C

6. Temperature Calibration

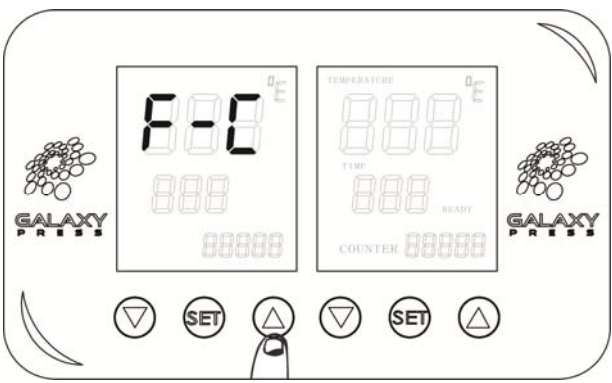
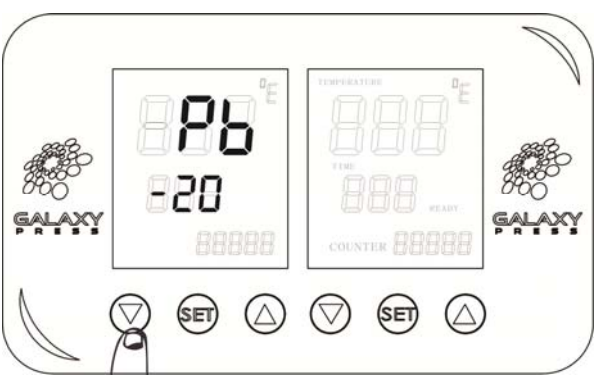
<p>Press and hold “up” button then press “set” button, display as below. Press “up” and “down” button to choose F or C.</p>	<p>Press and hold “down” button then press “set” button, display as below. Press “up” and “down” button to make temperature</p>
	

7.Separately turn on/off each station

8. Auto-sleep setting

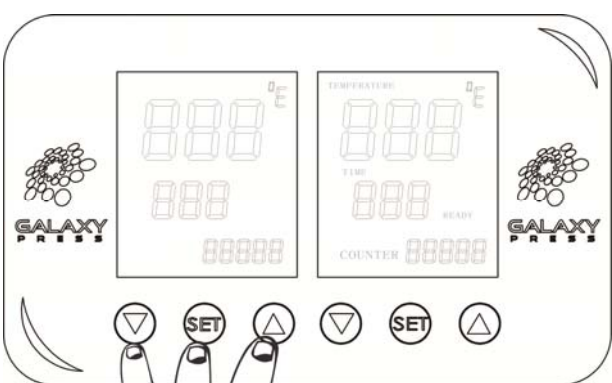
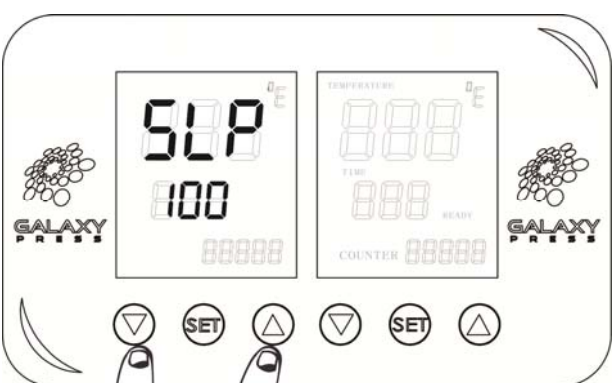
<p>When machine turns on,press “up” /“set” /“down” button together for three seconds to turn off each station’s circuit board.</p> <p>When machine turns off,press “up” /“set” /“down” button together for three seconds to turn on each station’s circuit board.</p>	<p>Press “up” and “down” button together and hold between 0~1s then release,display as below, press “up” and “down” button to set auto-sleep time.The unit of value is minute. After setting press “set” button to quit.</p>
	

Reset To Default

Press “up” and “down” button together for 5 seconds, reset machine to default.

Circuit Diagram (电路图)

