

Operation Manual

(GS-601-1115/GS-601-1515/GS-601-1620)

Safety Instructions

**When using your heat press,
basic precautions should always be followed,
including the following:**

1. Read all instructions.
2. Use heat press only for its intended use.
3. To reduce the risk of electric shock, do not immerse the heat press in water or other liquids.
4. Never pull cord to disconnect from outlet, instead grasp plug and pull to disconnect.
5. Do not allow cord to touch hot surfaces, allow heat press to cool completely before storing.
6. Do not operate heat press with a damaged cord or if the equipment has been dropped or damaged. To reduce the risk of electric shock, do not disassemble or attempt to repair the heat press. Take it to a qualified service person for examination and repair. Incorrect assembly or repair could increase the risk of fire, electric shock, or injury to persons when the equipment is used.
7. This appliance is not intended for use by persons (including children) with reduced physical, sensory or mental capabilities, or lack of experience and knowledge, unless they have been given supervision or instruction concerning use of the appliance by a person responsible for their safety.
8. Close supervision is necessary for any heat press being used by or near children. Do not leave equipment unattended while connected.
9. Burns can occur when touching hot metal parts.
10. To reduce the likelihood of circuit overload, do not operate other high voltage equipment on the same circuit.
11. If an extension cord is necessary, then a 20 amperage rated cord should be used. Cords rated for less amperage may overheat. Care should be taken to arrange the cord so that it cannot be pulled or tripped over.

Table Of Contents

Safety Instructions.....	1
Technical Parameters.....	3
Machine View.....	4
Control Panel Guide.....	5
Operating Instructions.....	6-9
● Connecting the System.....	6
● Turning the System On.....	6
● Adjusting the Temperature.....	7
● Adjusting the Time.....	7
● Adjusting the Pressure.....	7
● Printing and Pressing.....	8
● Switch Between F/C.....	8
● Temperature Clibration.....	9
Exploded Views And Parts List.....	10-13
Electrical Schematic.....	14

Technical Parameters

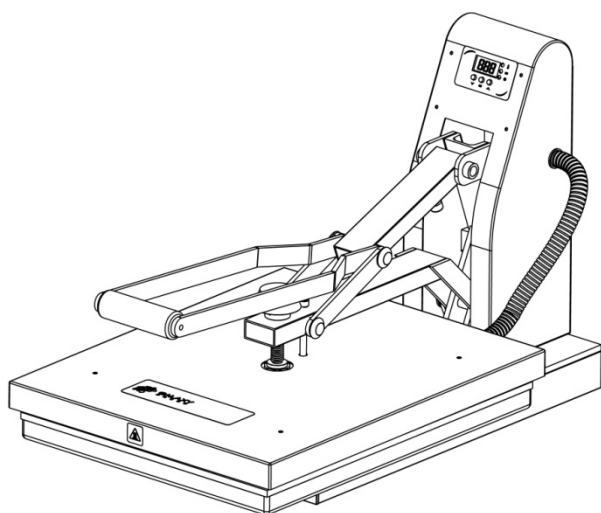

Model:	GS-601-1115	GS-601-1515	GS-601-1620
Heater Size:	11"×15" (280×381mm)	15"×15" (381×381mm)	16"×20" (406×508mm)
Pressure Display:	No	No	No
Auto Open:	No	No	No
Slide-out Lower Platen:	No	No	No
Power(120volt)	1800W/9Amps	1800W/16.4Amps	1800W/16.4Amps
Power(240volt)	1800W/4.5Amps	1800W/8.2Amps	1800W/8.2Amps
Temperature Range:	Max.221℃/430°F	Max.221℃/430°F	Max.221℃/430°F
Heating Up Time (180℃)	10minutes	20minutes	20minutes
Time Range:	0~999S	0~999S	0~999S
Way To Change Lower Platen:	Manual Change	Manual Change	Manual Change
Machine Size(open size):	66×30×83cm	66×40×86cm	80×42×93cm
Packing Size:	76.5×48.5×54cm	74×48×57cm	84×54×53cm
Packing Weight:	34kg	39kg	52kg
Certificate:	CE,FCC		
Warranty:	5years on upper heat platen, 1 year on parts		

Machine View

FRONT VIEW(GS-601-1620)

SIDE VIEW2 (GS-601-1620)

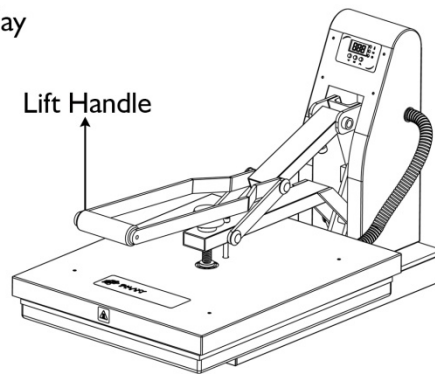
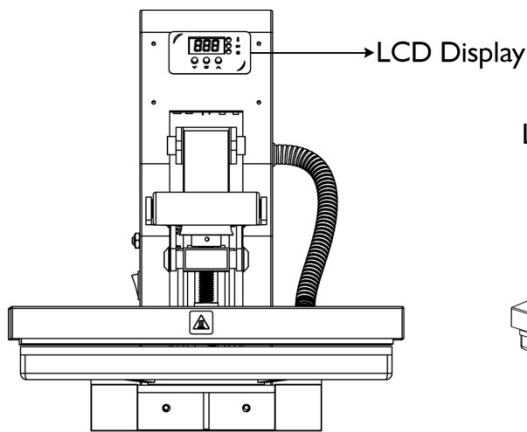

SIDE VIEW1 (GS-601-1620)

OPEN VIEW (GS-601-1620)

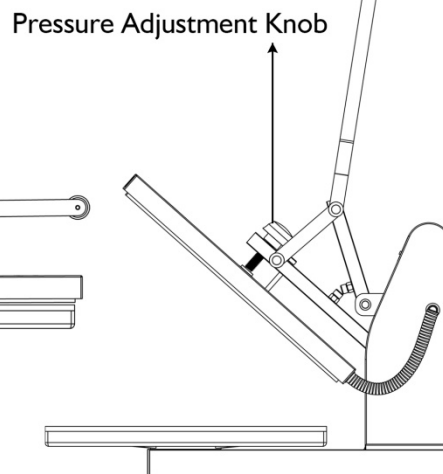
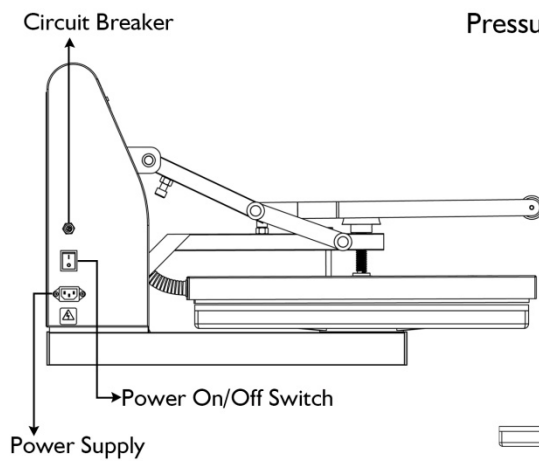

Control Panel Guide

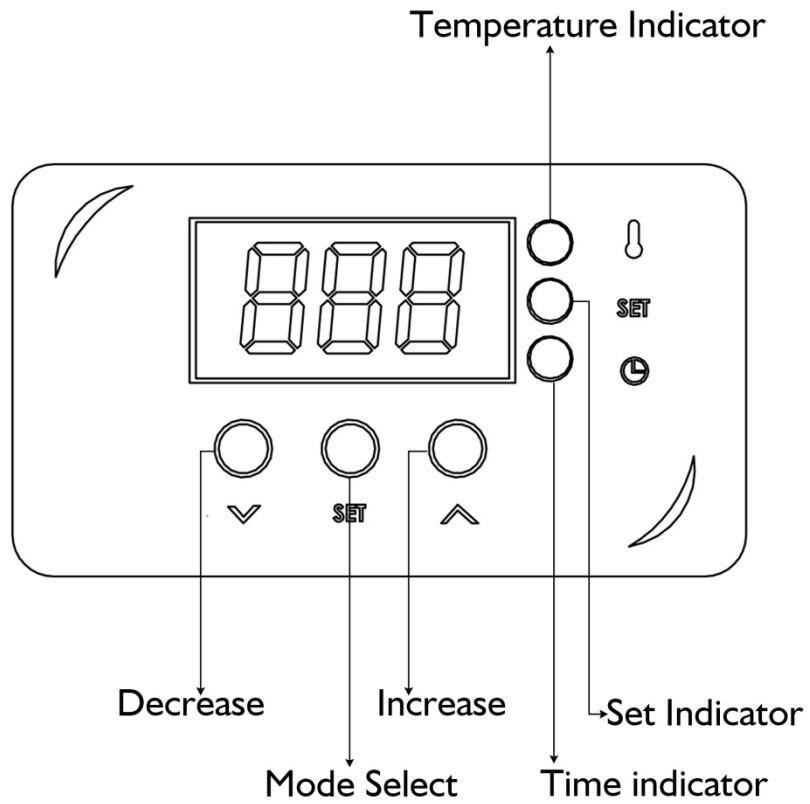

Operation Instructions

1. Connecting the System

1.1 Connect the power cord into a properly grounded electrical outlet with a sufficient amperage rating.

1.2 VOLTAGE

120 Volt – The GS-601 requires a full 20 amp grounded circuit for 120 volt operation.

240 Volt –The GS-601 requires a full 10 amp grounded circuit for 240 volt operation.

1.3 EXTENSION CORDS If used, should be as short as possible and not less than 12 gauge. Heavy duty cords are recommended.

1.4 CIRCUITS that have less than 15 amps or that have other high demand equipment or appliances (especially more than one heat seal machine) plugged in, should not be used.

NOTE: If the supply cord is damaged, it must be replaced by the manufacturer, its service agent or a similarly qualified person in order to avoid hazard.

CAUTION :

Failure to follow these instructions will cause:

- 1) Erratic controller functions.
- 2) Inaccurate displays and slow heat-up.
- 3) The circuit breaker to disengage.

2. Turn On the System

2.1 Switch The System On (figure 2.1)

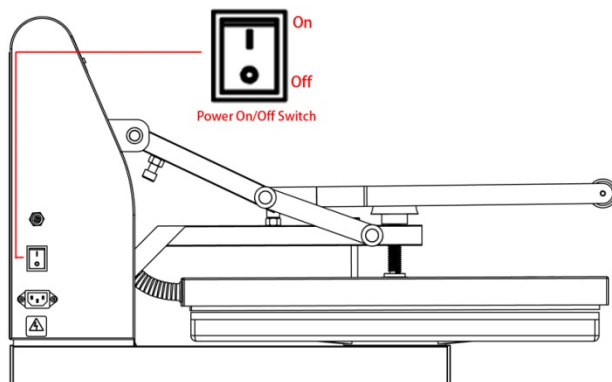

2.1

3.Adjusting the Temperature

3.1 Press the Mode Select button located in the center of the Control Panel.
“Temp” lights and “set” lights located in the display will illuminate indicating you are in the adjust temperature mode.(see figure 3.1)

3.2 Next, press the (-) button located to the bottom of the Mode Select button to lower the temperature setting,or press the (+) button located to top of the Mode Select button to raise the temperature setting.The temperature can be set from 0° F (0° C) to 430° F (221° C).

4.Adjusting the Time

4.1 Once you have adjusted the temperature, press the Mode Select button again.
“Time” lights and “set” lights located in the display will illuminate indicating you are in the adjust time mode. (see figure 4.1)

4.1 Next, press the (-) button located to the bottom of the Mode Select button to lower the value ,or press the (+) button located to top of the Mode Select button to raise the time value .The time setting range can be set from 0~999.

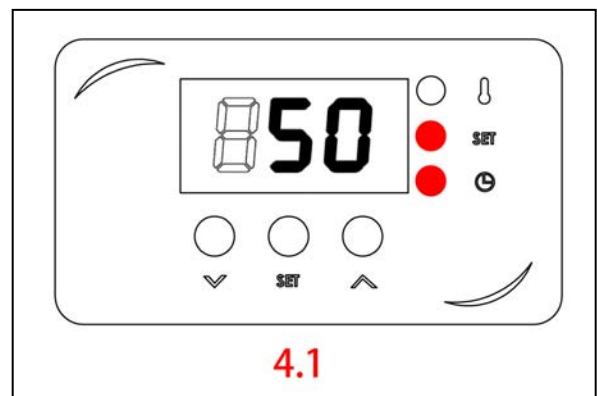
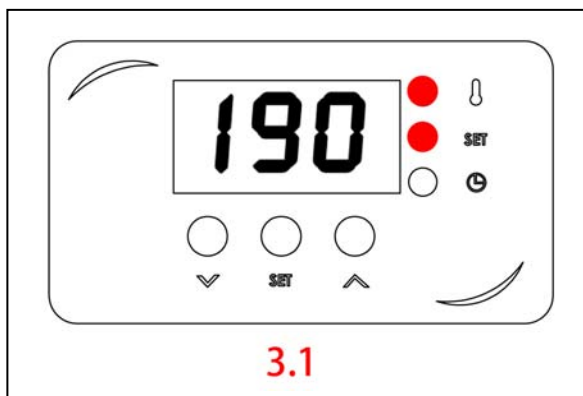

5.Adjusting the Pressure

5.1 The Pressure Adjustment Knob is located in the center of the heat platen(See figure 5.1)

5.2 Adjust the pressure by turning the knob clockwise to increase pressure and counter clockwise to decrease pressure.

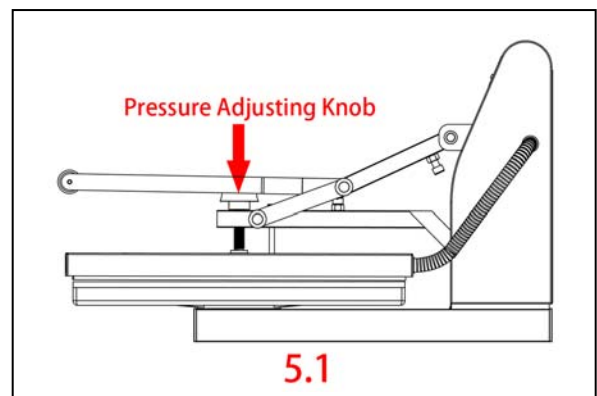

REMEMBER: To allow for the thickness of your garment when adjusting the pressure.

6. Printing And Pressing

- Once your equipment has reached the designated temperature:
- Position the garment and application and proceed to press. Lower and lock the heat platen into the press position.
- This procedure will start the automatic timing process.

- The timer will automatically count down and lift the heat platen into the "UP" position when the press cycle is complete.
- The time will automatically re-set and you are ready to continue with the next application.

7. Switch Between F/C

7.1 Press "set" button for 4 seconds, display shows LCK (See figure 7.1)

7.2 Input 68 to enter into second level menu (See figure 7.2)

7.3 Press "set" button to select "ctr" mode (See figure 7.3), press up and down button to set value at 0 or 1, 0 for celsius, 1 for Fahrenheit (see figure 7.4)

7.4 Press "set" button 4 seconds to quit.

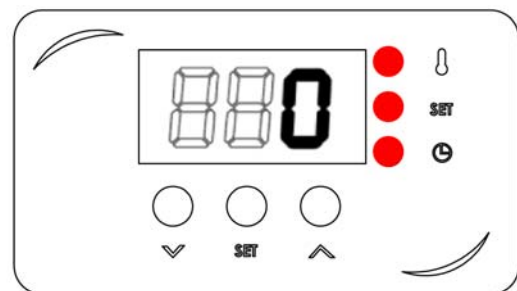
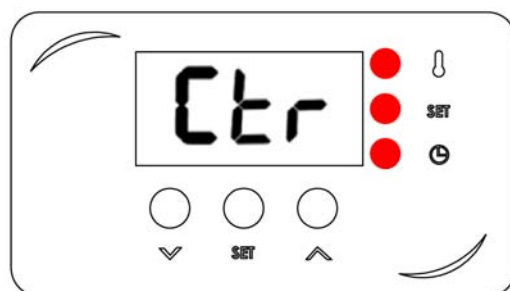
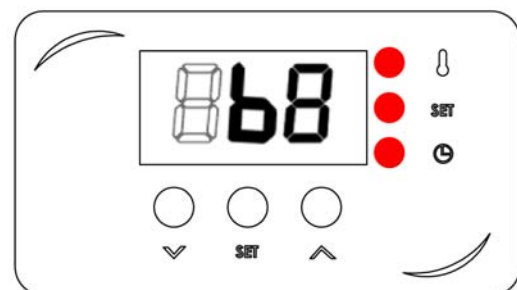
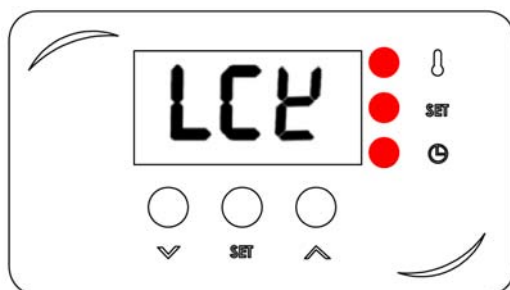

8. Temperature Calibration

8.1 Press “set” button for 4 seconds, display shows LCK (See figure 8.1)

8.2 Input 68 to enter into second level menu (See figure 8.2)

8.3 Press “set” button to select “Pb” mode(See figure 8.3) press up and down button to make temperature calibration (See figure 8.4)

8.4 Press “set” button 4 seconds to quit.

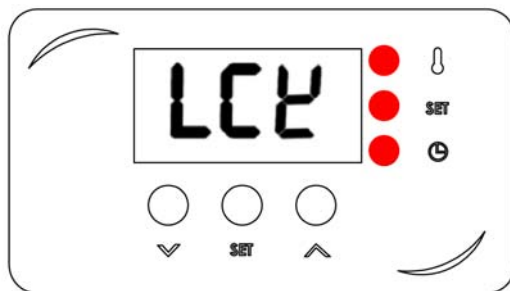

8.1

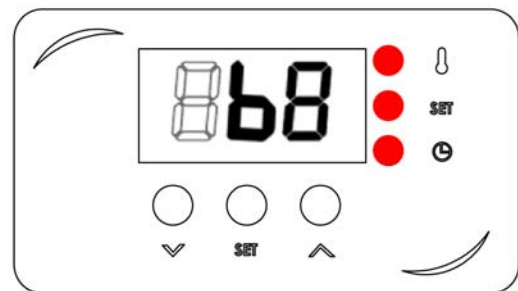

8.2

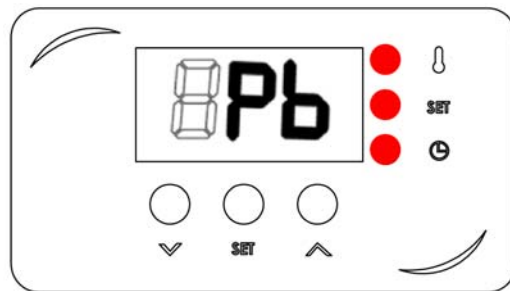

8.3

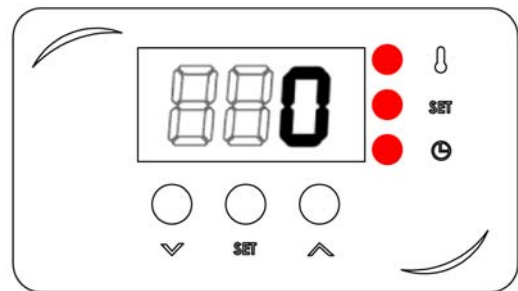

8.4

if temperature on heat platen is higher than circuit board shows,pls lower the Pb value.

Example:

Heat platen temperature:190C
Circuit board temperature:185C
Pls set Pb Value at (-5)

if temperature on heat platen is lower than circuit board shows,pls raise the Pb value.

Example:

Heat platen temperature:185C
Circuit board temperature:190C
Pls set Pb Value at (+5)

Exploded Views And Parts List

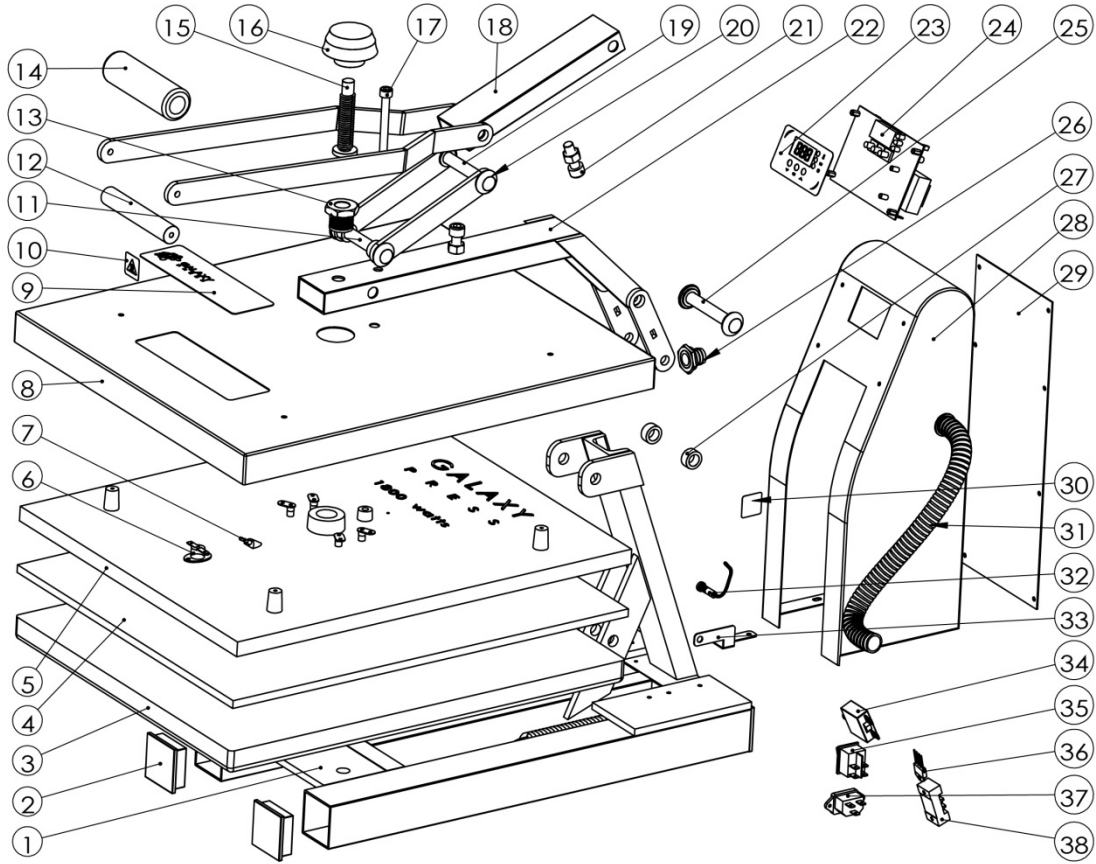

No.	Part Name(Chinese)	Part Name(English)	Part No.	Qty.	Remark
1	主支架磨砂黑 MS-NP1115-B	Base assembly	1300418	1	GS-601-1115 GS-601-1515
	主支架闪银 MS-NP1115-S	Base assembly	1300419	1	GS-601-1115 GS-601-1515
	主支架磨砂黑 MS-NP1620-B	Base assembly	1300416	1	GS-601-1620
	主支架闪银 MS-NP1620-S	Base assembly	1300417	1	GS-601-1620
2	方通堵头银 HSH-01-S	Rubber cover silver	1300551	4	GS-601-1115 GS-601-1515
	方通堵头黑 HSH-01-B	Rubber cover	1300552	4	GS-601-1115 GS-601-1515
	方通堵头银 HSH-02-S	Rubber cover	1300130	4	GS-601-1620
	方通堵头黑 HSH-02-B	Rubber cover	1300131	4	GS-601-1620
3	底板 LP-1115-A-S	Lower platen	1200384	1	GS-601-1115
	底板 LP-1515-A-S	Lower platen	1800380	1	GS-601-1515
	底板 LP-1620-A-S	Lower platen	1800387	1	GS-601-1620
4	硅胶垫 SP-1115-9-G	Silicon pad	1300670	1	GS-601-1115
	硅胶垫 SP-1515-9-G	Silicon pad	1800422	1	GS-601-1515
	硅胶垫 SP-1620-9-G	Silicon pad	1200539	1	GS-601-1620

5	发热板 HP-1115-A-S	Heat platen	1800732	1	GS-601-1115
	发热板 HP-1515-A-D	Heat platen	1200287	1	GS-601-1515
	发热板 HP-1620-A-S	Heat platen	1800386	1	GS-601-1620
6	突跳式温控器 TMS-01	Thermosat	1800133	1	
7	热电偶 THC-01	Thermocouple	1800281	1	
8	发热板罩壳(商标槽) 红 HC-NP1115-02-R	Heater cover	1300109	1	GS-601-1115
	发热板罩壳(商标槽) 浅绿 HC-NP1115-02-LG	Heater cover	1300108	1	GS-601-1115
	发热板罩壳(商标槽) 蓝 HC-NP1115-02-BL	Heater cover	1300110	1	GS-601-1115
	发热板罩壳(商标槽) 红 HC-NP1515-02-R	Heater cover	1300703	1	GS-601-1515
	发热板罩壳(商标槽) 浅绿 HC-NP1515-02-LG	Heater cover	1300701	1	GS-601-1515
	发热板罩壳(商标槽) 蓝 HC-NP1515-02-BL	Heater cover	1300702	1	GS-601-1515
	发热板罩壳(商标槽) 深绿 HC-NP1515-02-DG	Heater cover	1300700	1	GS-601-1515
	发热板罩壳(商标槽) 红 HC-NP1620-02-R	Heater cover	1300677	1	GS-601-1620
	发热板罩壳(商标槽) 蓝 HC-NP1620-02-BL	Heater cover	1300678	1	GS-601-1620
	发热板罩壳(商标槽) 深绿 HC-NP1620-02-DG	Heater cover	1300679	1	GS-601-1620
	发热板罩壳(商标槽) 浅绿 HC-NP1620-02-LG	Heater cover	1300676	1	GS-601-1620
10	高温标签 BQ-02	High temperature sticker	1800950	1	
11	销轴12.5-94银 PR-01-S	Steel pin	1300683	2	GS-601-1115 GS-601-1515
	销轴12.5-94银 PR-01-S	Steel pin	1300683	2	GS-601-1620
12	手柄轴(Φ20*118) TB-35	Handle shaft	1300150	1	
13	紧固螺母 GC1-104	Adjustment spindle bottom	1800142	1	
14	手柄轴胶套(内径19*T5*123mm) TB-112	Foam grip	1300155	1	
15	调节螺栓1 GH-47	Adjustment spindle	1800087	1	
16	调压旋钮塑胶红 PK-R	Pressure knob	1800480	1	
	调压旋钮塑胶浅绿 PK-LG	Pressure knob	1800479	1	
	调压旋钮塑胶浅蓝 PK-BL	Pressure knob	1800481	1	
	调压旋钮塑胶深绿 PK-DR	Pressure knob	1800156	1	
17	杯头螺栓黑 M8*100	Balance screw	1900877	1	
18	手柄闪银 HS-NP1115-S	Handle assembly	1300405	1	GS-601-1115
					GS-601-1515

	手柄磨砂黑 HS-NP1115-B	Handle assembly	1300692	1	GS-601-1115 GS-601-1515
	手柄闪银 HS-NP1620-S	Handle	1300404	1	GS-601-1620
	手柄磨砂黑 HS-NP1620-LG	Handle	1300402	1	GS-601-1620
20	快速螺母黑 WSH-02	Hucap	1900390	6	
	快速螺母银 WSH-03	Hucap	1900391	6	
22	弯臂闪银 BA-NP1115-S	Adjustment arm assembly	1300406	1	GS-601-1115 GS-601-1515
	弯臂磨砂黑 BA-NP1115-B	Adjustment arm assembly	1300690	1	GS-601-1115 GS-601-1515
	弯臂闪银 BA-NP1620-S	Adjustment arm assembly	1300545	1	GS-601-1620
	弯臂磨砂黑 BA-NP1620-B	Adjustment arm assembly	1300403	1	GS-601-1620
23	控制板面贴浅绿 STK-GS601-LG	Display overlay	1600233	1	
	控制板面贴红 STK-GS601-R	Display overlay	1600455	1	
	控制板面贴蓝 STK-GS601-BL	Display overlay	1600456	1	
24	控制板 GSK-H05	Circuit board	1800355	1	
25	销轴12.5-74银 PR-07-S	Steel pin	1800952	1	GS-601-1620
	销轴12.5-94银 PR-01-S	Steel pin	1300683	1	GS-601-1115 GS-601-1515
26	波纹管接头银 TCR-01-S	Tube connector	1800145	1	
	波纹管接头黑 TCR-01-B	Tube connector	1800135	1	
28	控制板罩壳红 CC-NP1115-R	Control box cover	1300489	1	GS-601-1115 GS-601-1515
	控制板罩壳浅绿 CC-NP1115-LG	Control box cover	1300487	1	GS-601-1115 GS-601-1515
	控制板罩壳蓝 CC-NP1115-BL	Control box cover	1300488	1	GS-601-1115 GS-601-1515
	控制板罩壳红 CC-NP1620-R	Control box cover	1300485	1	GS-601-1620
	控制板罩壳蓝 CC-NP1620-BL	Control box cover	1300486	1	GS-601-1620
	控制板罩壳浅绿 CC-NP1620-LG	Control box cover	1300484	1	GS-601-1620
	控制板罩壳深绿 CC-NP1620-DG	Control box cover	1300680	1	GS-601-1620
29	控制板背板 红 CS-NP1115-R	Back cover	1300123	1	
	控制板背板 蓝 CS-NP1115-BL	Back cover	1300121	1	
	控制板背板 深绿 CS-NP1115-DG	Back cover	1300124	1	
	控制板背板 浅绿 CS-NP1115-LG	Back cover	1300122	1	
30	电压标签 ELE-K005	Voltage alarm sticker	1800735	1	
31	PP阻燃波纹管Φ17*21.2	PP tube 0.13M	1800835	1	GS-601-1115 GS-601-1515
	PP阻燃波纹管Φ17*21.2	PP tube 0.3M	1800835	1	GS-601-1620
32	柱形门磁(车牙加工) MC-0627	Magnet switch	1800620	1	
33	门磁卡座N NP1-101	Proximity Switch base	1800982	1	GS-601-1620
34	过载保护器8A L1080271504-01	Circuit breaker 8A	1800348	1	GS-601-1115-220V
	过载保护器15A L1150271504-01	Circuit breaker 15A	1800160	1	GS-601-1115-110V

					GS-601-1515-220V GS-601-1620-220V
	过载保护器18A L1180279508-00	Circuit breaker 18A	1800349	1	GS-601-1515-110V GS-601-1620-110V
35	船型开关 RK1-01	On/off switch	1800346	1	
36	可控硅 DX170105-C	Traic	1800951	1	
37	IEC插座 DB-14-1	socket	1800344	1	
38	双排三位栅栏接线排 TB1503L	Terminal block	1800345	1	

Electrical Schematic

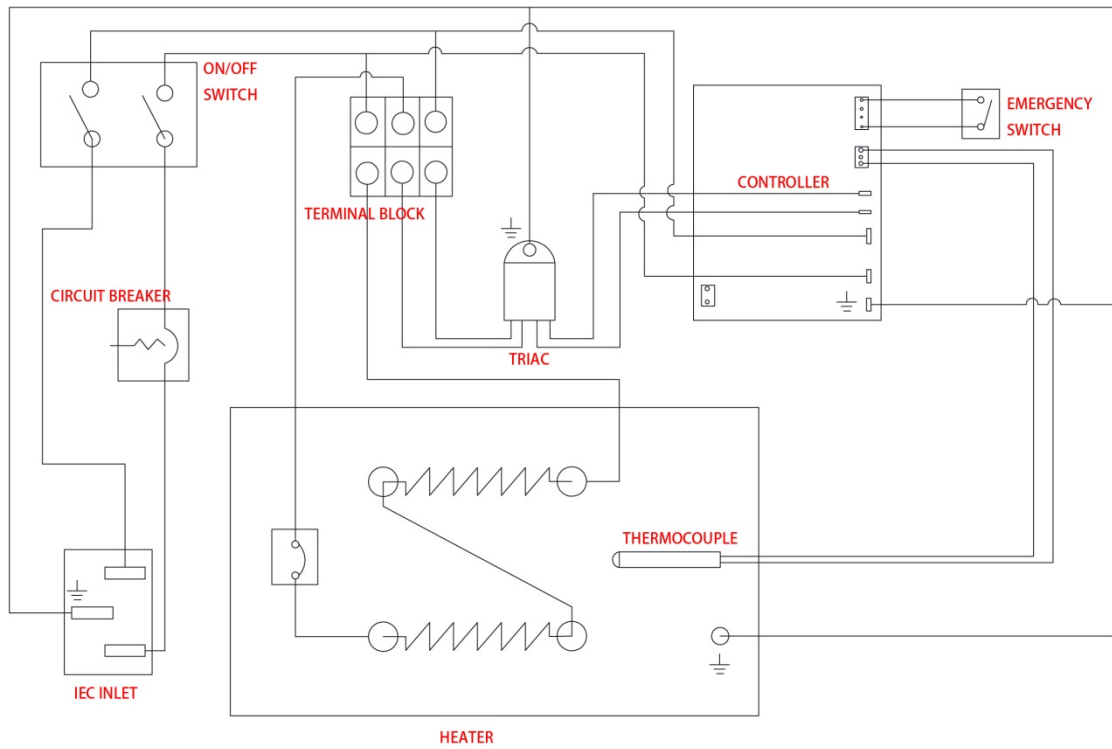

220V VERSION

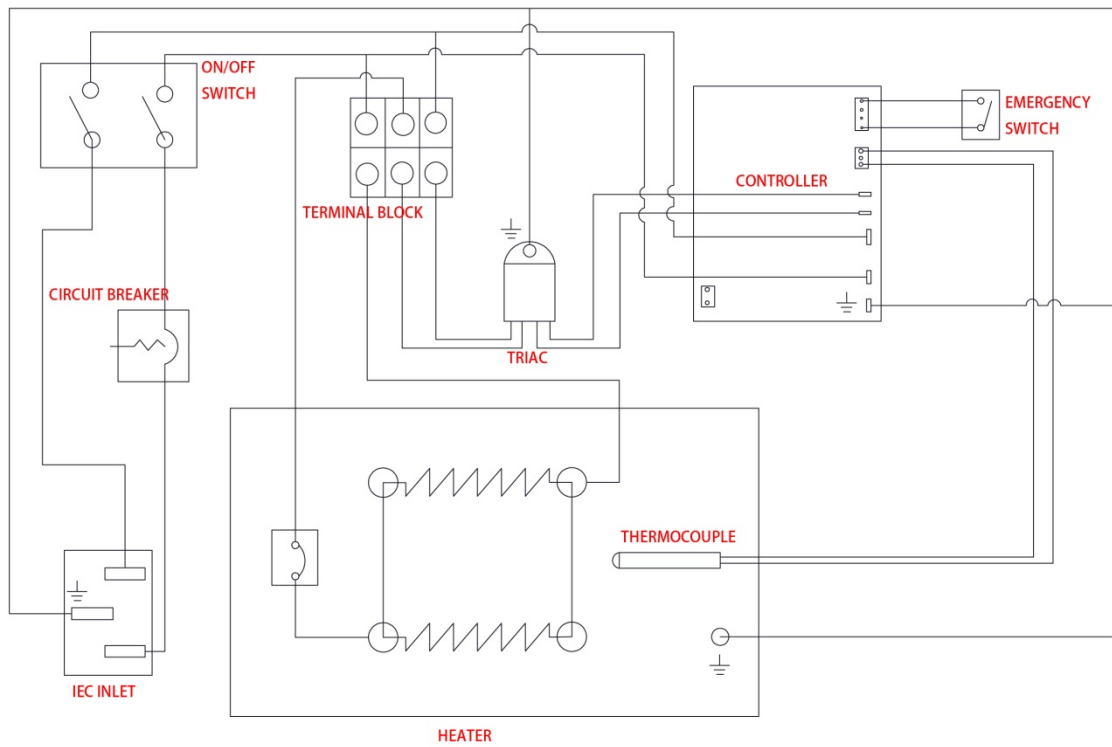

110V VERSION