

# MaxArmour Combo Heat Press Manual

Model No.: MAX-800

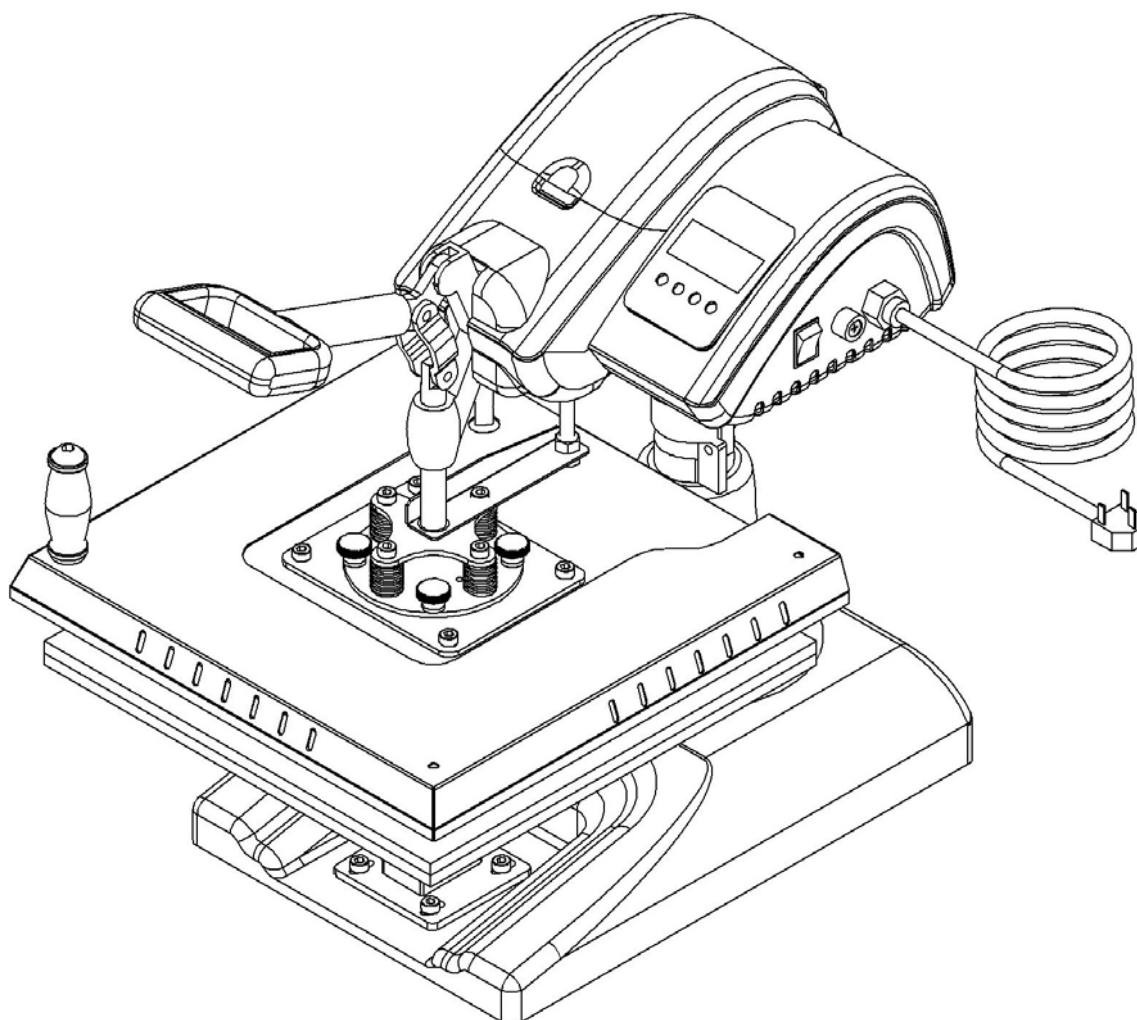

## CONTENTS

I. Assembly Drawing .....	2
II. Technical Parameters .....	2
III. Operation Process .....	3-5
IV. Maintenance .....	6
V. Trouble Shooting For Transfer Print Quality.....	6
VI. Circuit Diagram .....	7
VII. Explosion View .....	8

# I. ASSEMBLY DRAWING

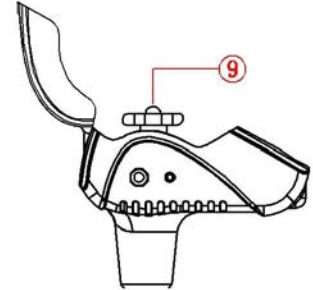
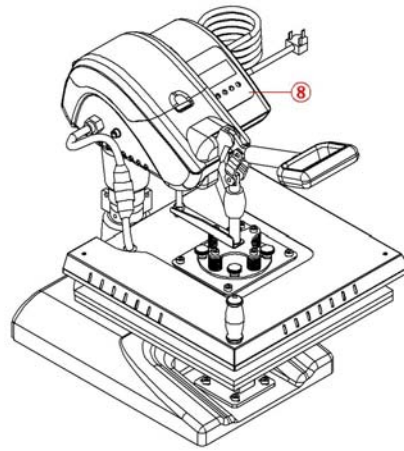
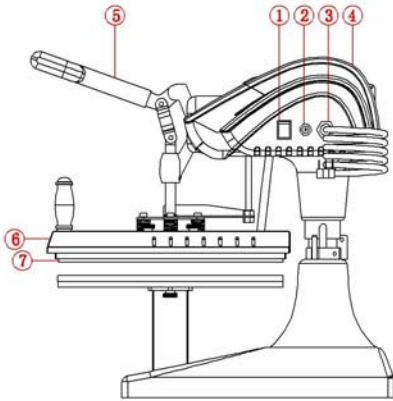

①Power Switch

④Electrical Case

⑦Under Plate

②Fuse

⑤Handle Bar Grip

⑧GY-05 Digital Controller

③Power Cord

⑥Flat Heat Platen

⑨Hand Wheel

# II. MAX-800 Technical Parameters

1. **Model No.:**MAX-800
2. **Machine Size:** 590\*580\*390mm
3. **Heat platen Size:**15"x15"(380x380mm)
4. **Printable Articles Max Size:**380\*380\*30mm
5. **Voltage:** 220v/1Phase/120v/1Phase
6. **Power:** 2kw Heating tube power:1.8kw\*1/1.2kw
7. **Maximum Time.:** 0-999C
8. **Recommend Setting:** 30~280s; 180~200°C  
Time Range: 0~999s  
Maximum Temp: 225 C
9. **Packing Size:** 700\*700\*500mm
10. **Gross weight:**55kg

# III. Operation Process

## 1. How to exchange the heat element

### Plate Heat Element

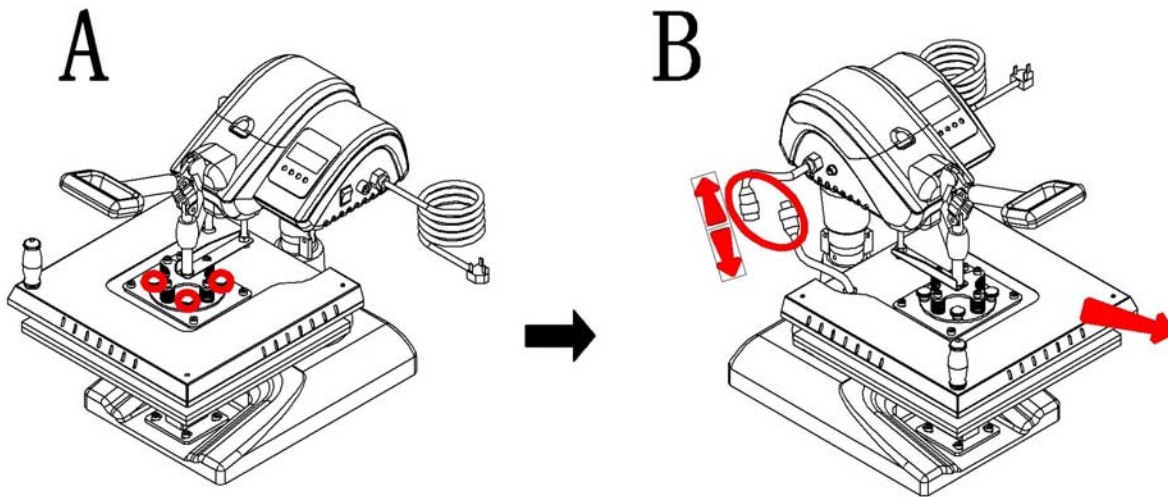

Please loosen the screws marked in red

Disconnect the wire socket as the above picture shown.

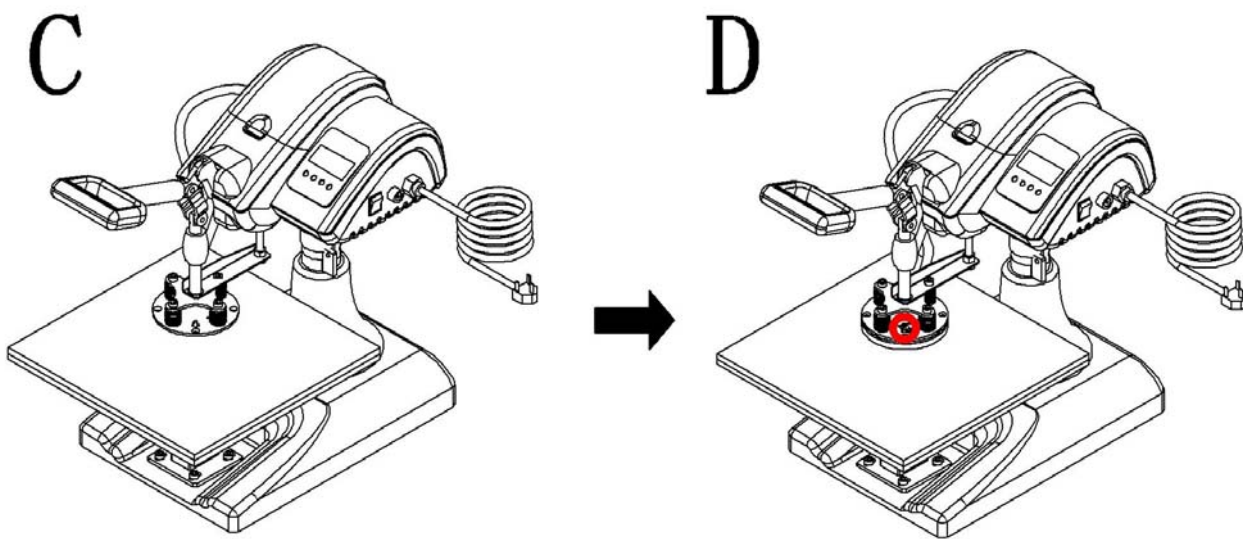

Remove the heat platen and install the plate heater

Tighten the screws of plate heat element and connect the wire socket.

## Mug Heat Element

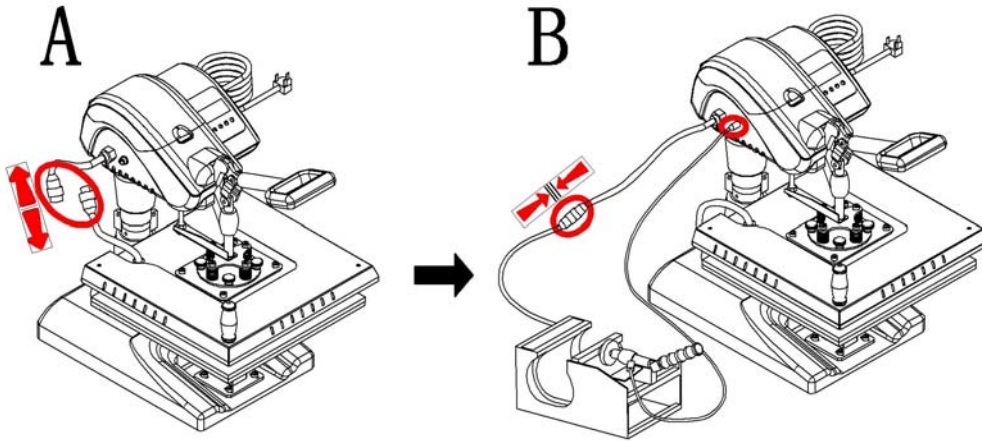

Disconnect the heat platen wire. Connect the mug press, one socket is power socket, the other one is limit switch socket.

## Cap Heat Element

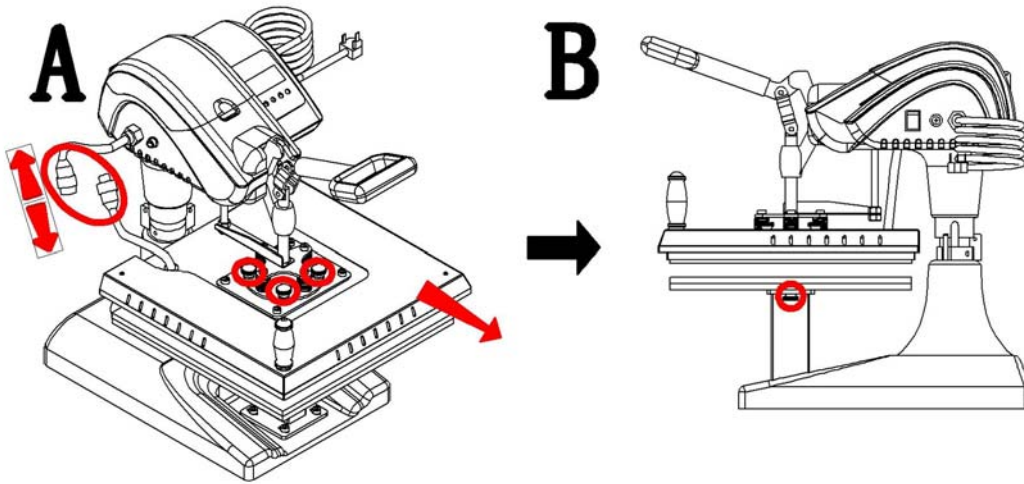

Loosen the screws marked in red

Remove the heat platen and under plate

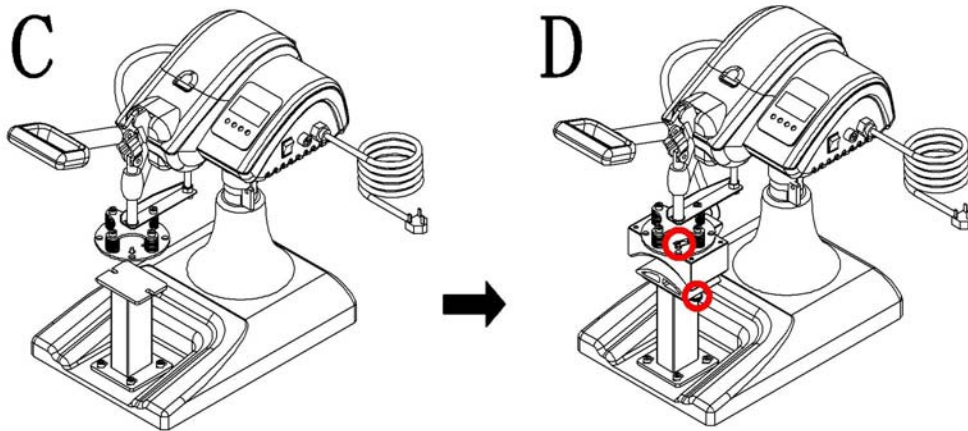







The machine is like the above picture now







Tighten the screws (marked in red) of cap heat element, then connect the wire



## 2. Set temperature required

		
<p>Turn on power switch, temperature light is ON. The digital display shows OFF .</p>	<p>Press  button, the C/F light is on (C denotes Celsius). Press arrows “△” or “▽” to select “°C” or “°F” (F denotes Fahrenheit) according to your habits.</p>	<p>Press  button, the temp  light is on. Select with arrows the temperature according to different transfer material (such as 360°F).</p>

## 3. Set time required

		
<p>Press  button after temperature setting and the  time light is on. Select with arrows the time according to different transfer material (such as 260s).</p>	<p>Press  button after time setting; the display shows the temperature starts to rise. When the temperature rises to the setting temperature, the buzzer sends out sounds; then close down heat platen (meantime the sounds stop) and starts to transfer.</p>	<p>When you close the heat platen and start to transfer, the time starts to count down, once time is up, open the heat platen and start the next cycle.</p>

## 4. Printing methods

**Step 1:** Make sure the cord is connected well to the wall socket. Place the object (i.e. T-shirt) on press bed, and transfer paper with images facing down the object, adjust pressure to your requirement, and turn on the power.

**Step 2:** Set the temperature and time required, then temperature starts to rise.

**Step 3:** When the temperature rises to the setting temperature, the buzzer sends out sounds; then close down heat platen (meantime the sounds stop) and starts to transfer.

**Step 4:** Then the time counter is on, once time is up, the upper heat platen will auto open and swing away to another side automatically.

**Step 5:** Consult the Transfer Paper instructions on whether to peel cold or hot, Here are suggested Pressing time guidelines for different transfer paper.

Ink-Jet Transfer Paper (fabric) 14-18 seconds

Laser Copier/Printer Transfer Paper (fabric) 18-25 seconds

Sublimation Transfers (onto Fabrics) 25-30 seconds

Sublimation Transfers (onto FR-Plastic/Woods) 60-70 seconds

## 5. Recommendations:

1) Ceramic tile transfer: (Mugs & Plates transfer is similar)

Set temperature: 180°C.

Set time: 15 seconds

2) T-shirt transfer:

Set temperature: 180°C.

Set time: (chemical fiber use for sublimation transfer paper: 30-50seconds; pure cotton use for T-shirt transfer paper: 10-20seconds)

**Step 6:** When the temperature rises to the set temperature, the buzzer sends out a sound; then close down heat platen(meantime the sounds stop) and starts to transfer.

**Step 7:** Time is counting down; once time is up,the buzzer will send out a sound again, the heat platen will open automatically (meantime the sounds stop).

**Step 8:** Work finish and take out the cap. If you want to print on another cap, press  button and confirm the time and temperature set as last time, then repeat above process.

## NOTE:

1) Please switch off the machine and unplug the power cord when the machine is not in use.

2) The heat platen will cool down to the room temperature, if heat press stays unuse for more than 30 minutes.

3) The heat-releasing fan will automatically starts when the temperature of heat platen reaches 80 degree C (176 degree F). It helps to reduce the temperature of electrical parts and prolong the service life of them.

4) For better maintenance of heat press, the maximum setting temperature is 210 degrees C (410 degrees F).

5) To avoid re-heating the first transfer when printing double sided T-Shirts, insert a sheet of cardboard in between the shirt, adjust the height to less pressure, then press.

6) Heat platen may pivot slightly back and forth rotationally. This is due to movement allowance within the clamp assembly, and is normal.

## IV. Maintenance

### 1. No action after turn on the machine

- 1). Check the plug whether it connects well or whether it is broken.
- 2). Check the power switch or digital controller whether it is broken.
- 3). Check the fuse whether it has been burnt out.
- 4). Indicating light is on, but no display on screen, check the 5 cable of Railway transformer. If it's loosening, showing the problem is poor connection. If they connects well, showing that the Transformer is faulty.

### 2. The display screen are working well, but no temperature increasing on the heat platen.

- 1). Check whether the thermocouple of the heat platen touches well. If the thermocouple is loose, the display will show 255 and machine keeps beeping.
- 2). Check if the indicating light of solid-state relay is on, if not, check if the relay or digital controller is broken.
- 3). If you already changed the new solid-state relay but the heat platen still can't heating up, check if the heat platen is faulty or the heat platen's power cable is loose, need to change by new heat platen.

### 3. The heat platen works well, but suddenly the display screen show 255°C.

- 1). Check whether the thermocouple of the heat platen touches well.
- 2). If the thermocouple touches well but still show 255°C, then it is faulty.

### 4. The machine is heating during 0~180°C, but display number jumps to above 200°C or 300°C suddenly, or the numbers on display jumps irregularly.

- 1). Check whether the thermocouple of the heat platen touches well.
- 2). If the thermocouple is good, It shows that the program of digital controller is broken, which namely IC or is broken, need to change by new controller.

### 5. The temperature is out of control: Set 180°C, but the actual temperature is above 200°C.

- 1). It means the solid-state relay is broken, out of control, need to change the relay.
- 2). Or the digital controller is faulty and it keeps conveying electric to relay, need to change controller.

### 6. The setting temp and time becomes abnormal after exchange the heat platen

- 1). Please reset the temp and time according the operation process manual.

### 7. Other notice

- 1). In order to prolong the machine service life, please add the lubrication oil regularly on the joints.
- 2). In order to keep the heat platen's good transfer effect, you need to protect the heat platen carefully whenever you are using it or not.
- 3). Please keep the machine in dry place.
- 4). If you are not able to solve the electrical parts problem, please kindly contact the supplier and get technical support.

## V. Trouble shooting for transfer print quality

1. If the print color is pale: the temperature is too low / the pressure is not correct / or not pressed long enough.
2. If the print color is too brown or the transfer paper is almost burnt: reduce the setting temperature
2. If the print is blurring: too much transfer time causes proliferation.
3. If print color is different/ partial transfer effect is not good enough: the pressure is not enough / or not pressed long enough / or poor quality transfer paper.
4. If transfer paper stick to the object after transfer: the temperature is too high/ or poor quality printing ink.

# VI. Circuit Diagram

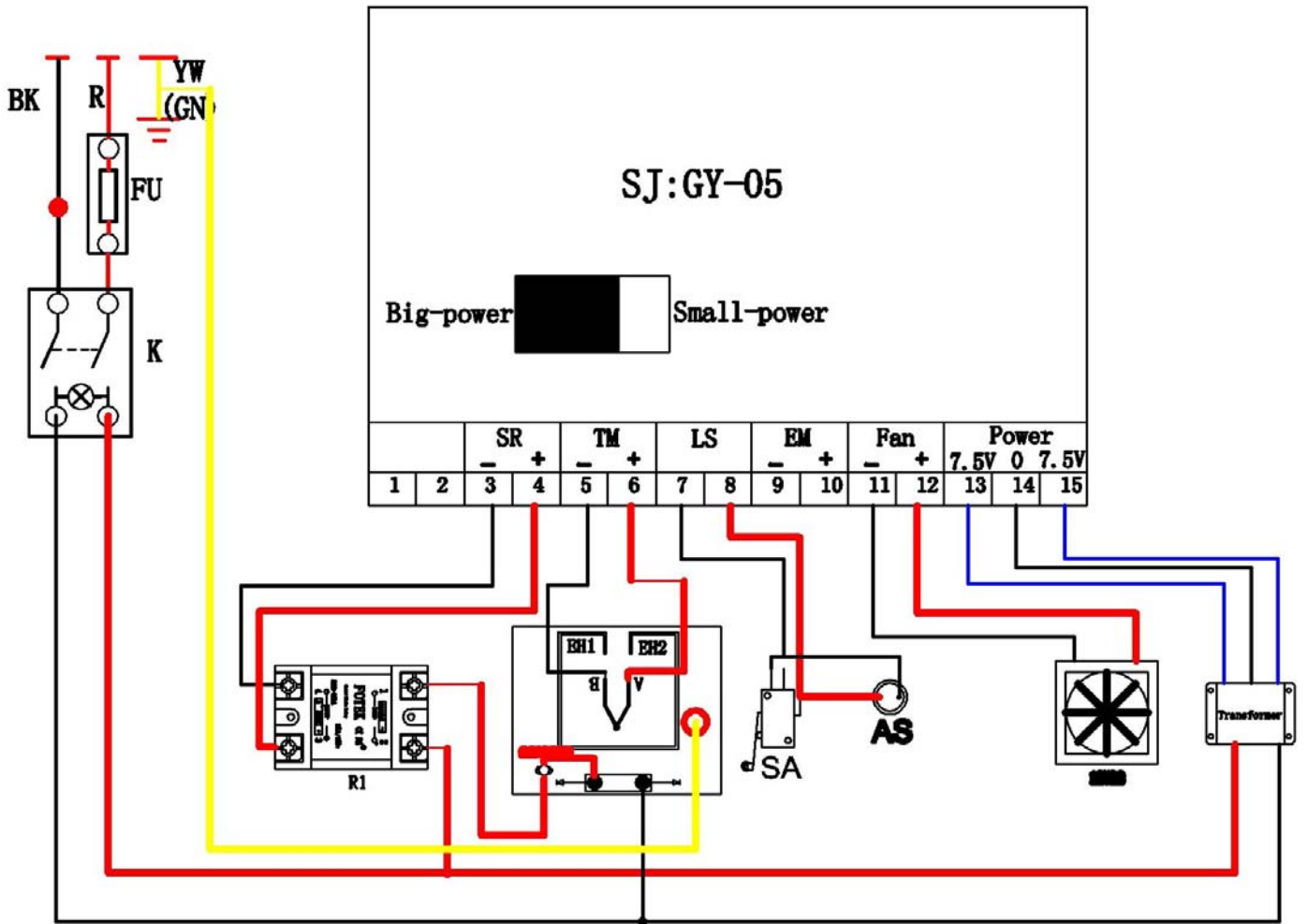

K: Power switch  
SA: Limit Switch

FU: Fuse  
SJ: Digital Controller

R1: Relay



## VII. Explosion View

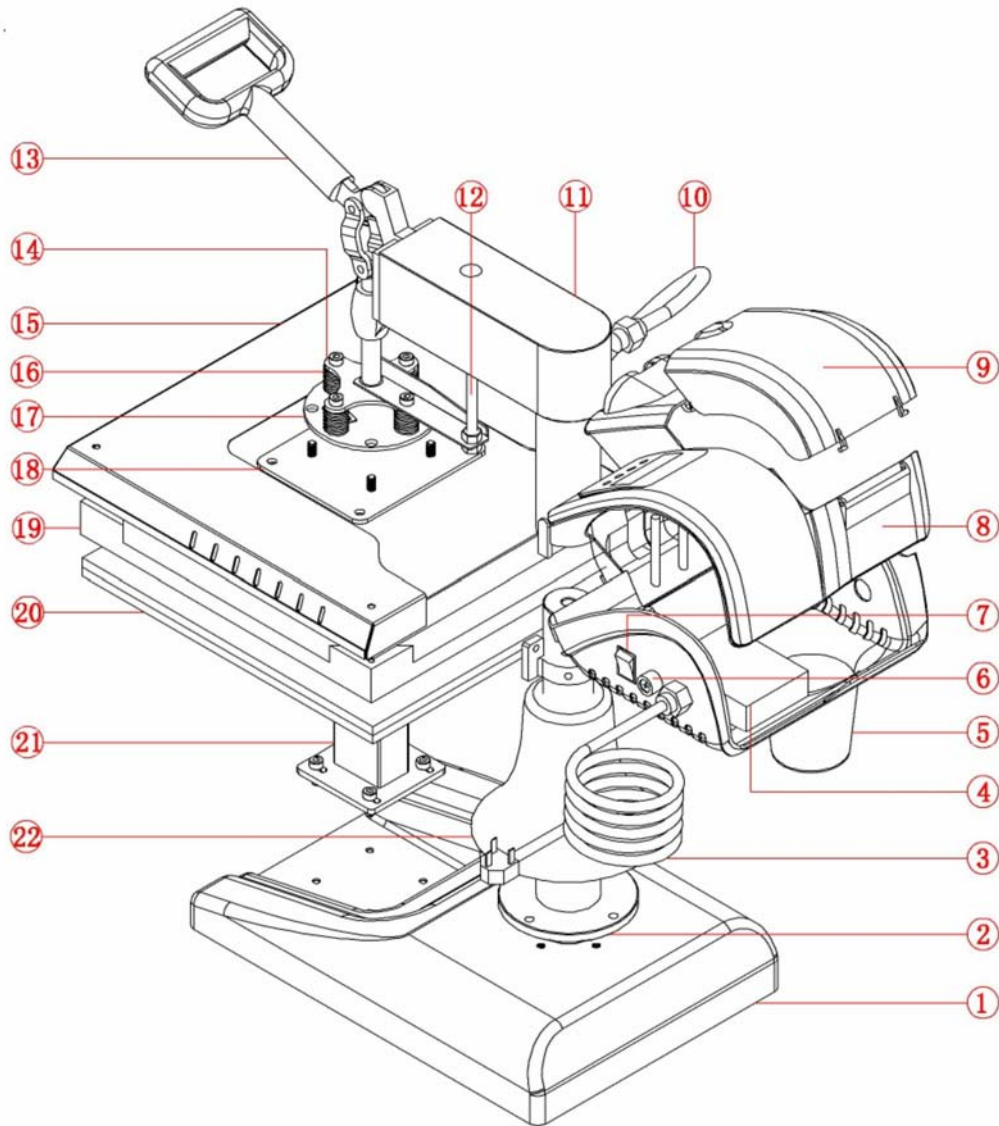

No.	Part Name	Qty
1	Machine Base	1
2	Column	1
3	Power Cord	1
4	Electrical Parts Bracket	1
5	Electrical Case	1
6	Fuse Holder	1
7	Power Switch	1
8	Electrical Case Paper Part	1
9	Electrical Case Cover	1
10	Serpentuator	1
11	Swing Arm	1

12	Support Shaft	1
13	Handle	1
14	Adapter Plate	1
15	Heating Plate Cover	1
16	Compression Spring	4
17	Connecting Plate	1
18	Adapter Plate	1
19	Heat Platen	1
20	Under Plate	1
21	Support Plate	1
22	Shield for Column	1