

# Fitness Equipment Manual

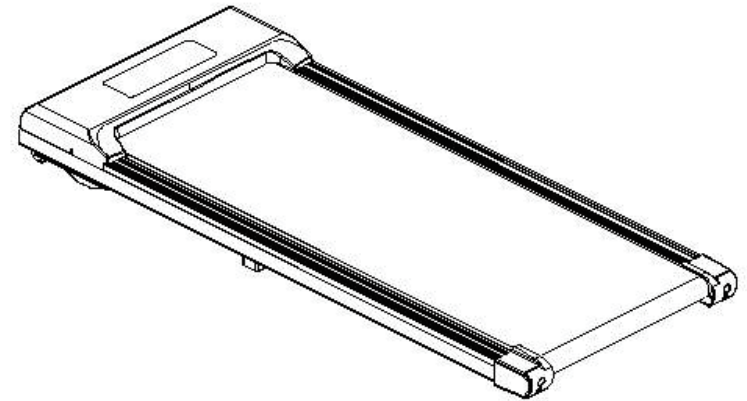

## Contents

About the Product.....	01
Safety precautions and warning instructions.....	02-03
Exercise suggestions and guidelines .....	04
Product instructions.....	04
Product maintenance.....	05
Technical parameter.....	06



### After-Sale Service

Our customer service is friendly and hassle-free, please feel free to contact us if you have any issue:

- 1 Refund or Replacement
- 1 Technical Support
- 1 Package not in perfect condition
- 1 Orders out of Amazon Return

Please contact us in your Buyer Center by sending a message on line with order ID.

Or contact us directly by e-mail: [besif016@gmail.com](mailto:besif016@gmail.com)

### I . About the product

The names of all parts of the model are shown as follow:

Caution:

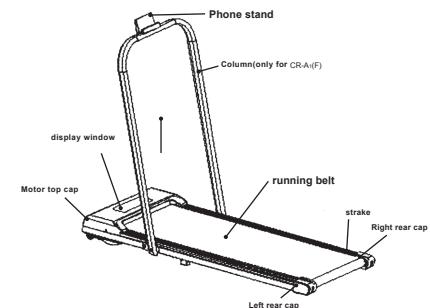

Note:

Before assembly, please refer to the assembly instructions carefully. If assembly difficulties still occur, please ask our customer service.

If the product fails due to improper human activities and forced assembly, return and exchange are not accepted!

Return and replace the goods together with the main goods and accessories in accordance with the original packaging method. If there is any human factor, the missing parts (outer boxes or spare parts) must be compensated according to the original price.

In order to ensure the safety, when the machine is running, it is strictly prohibited to move or touch the machine body at will, so as to avoid accidentally pinching fingers or body. We shall not be responsible for improper use.

Safety area: 1000mm \* 1000mm behind the device, 500mm on the left and right sides of the device.

#### Packing list

No.	Item	Unit	Quantity
1	Main body	set	1
2	Bottled silicone oil	bottle	1
3	5#Allen wrench	set	1
4	remote control	set	1
5	Instruction manual	copy	1

Please read this manual carefully before using it.

Please keep this manual for use

The appearance, color or surface pattern of the product shall be subject to the actual conditions.

Our products are constantly updated and subject to change without notice.

## II. Safety precautions and warnings

**Note:** please read the manual carefully before use and pay attention to the following safety precautions

- This machine is suitable to be placed indoors to avoid being affected with damp. Water cannot be splashed on the machine and no foreign matter can be placed.
- Before exercise, please wear appropriate sportswear and sneakers. Any movement or stretching barefoot is strictly forbidden.
- The power plug must be reliably grounded, and the socket must have a special circuit to avoid sharing with other electrical equipment.
- Children should stay away from the machine to avoid accidents.
- It is necessary to avoid overload operation for a long time, otherwise motor and controller will be damaged, wear and aging of bearing, running belt and running plate will be accelerated, and regular maintenance shall be done.
- Reduce indoor dust, keep a certain humidity and avoid strong static electricity, otherwise it may interfere with the normal operation of the electronic meter and controller.
- Please turn off the power of the machine after use.
- Please keep indoor air circulation when using the product.
- During the movement, please clamp the safety key cable on the clothes to ensure the safe shutdown in case of emergency
- If you feel uncomfortable or abnormal during use, please stop exercising and consult your doctor.
- After the use of silicone oil, it must be stored in a place not accessible to children to avoid serious consequences caused by ingestion.

**Warning:** In order to reduce accidents or injuries to others, please observe the following regulations:

- Before using the product, please check whether the clothing is properly buckled or worn and aged, and make regular maintenance.
- Don't wear clothes that are easily hooked by the machine.
- Keep the power cord away from hot objects.
- Keep children away from the machine.
- Do not use the machine outdoors.
- Power must be cut off before moving the machine.
- Non-professionals are not allowed to disassemble the machine without authorization, otherwise serious consequences may occur.
- This machine is only used in 20 amp circuits.
- Only one person can move on the machine when the machine is started.
- If you feel dizzy, chest pain, nausea or shortness of breath during exercise, please stop exercising immediately and consult a doctor.

**Warning! Attention!**

- If you are under the treatment of a doctor or the following patients, please consult with a special doctor before using.
- (1) Those who are suffering from waist pain now or those who have suffered injuries to their legs, waist and neck in the past. Numbness of legs, waist, neck and hands (chronic diseases such as disc herniation, spondylolisthesis, cervical vertebra protrusion, etc.)
- (2) those with deformational arthritis, rheumatism and gout.
- (3) Abnormal osteoporosis.
- (4) Persons with circulatory disorders (heart disease, vascular disorders, hypertension, etc.).
- (5) respiratory organ dysfunction
- (6) Implantable medical electronic instruments using artificial heart rate regulators.
- (7) Patients with malignant tumors.
- (8) those with thrombosis or severe lipoma, blood circulation disorder or various skin infections and other symptoms.
- (9) Persons with perceptual disorders caused by high peripheral circulation disorders such as diabetes.
- (10) People with skin trauma.
- (11) Persons with high fever (38 degrees or above) due to illness, etc.
- (12) Abnormal or curved dorsal bones.
- (13) Those who are pregnant or may be pregnant or are in menstrual period.
- (14) Those who feel abnormal and need rest.
- (15) Those who are obviously in poor physical condition.
- (16) for the purpose of rehabilitation.
- (17) In addition to the above situations, people feel abnormal in their bodies.

—May lead to accidents or poor health.

◆ When you feel waist pain, numbness of legs and feet, dizziness, heartbeat and other physical pain different from usual or abnormal sensation caused by coordination during exercise, immediately stop using it and consult a doctor.

Don't let children use this product, and don't let children play around this product.

—Failure to comply may result in injury.

◆ Please make sure that there are no people or pets around (the rear, lower and front parts of the product) during use or when loading and taking out the product or sliding it.

**Forbidden!**

◆ Don't use it when the shell is cracked, broken or detached (internal structure leaks out) or when the welded part is detached.

— otherwise accidents or injuries may occur.

◆ Don't jump up or down during exercise.

—injuries may result from falls.

◆ Do not use and keep it in damp places such as outdoors and near bathrooms and places that are prone to dripping water.

◆ Do not use or keep it in places with direct sunlight, places with high temperature such as around stoves, and heating appliances such as electric heating carpets.

—No may lead to electricity leakage and fire.

## III. Installation instructions

1. Open the package, take out the assembly materials in the box, and lay the main part on the ground;

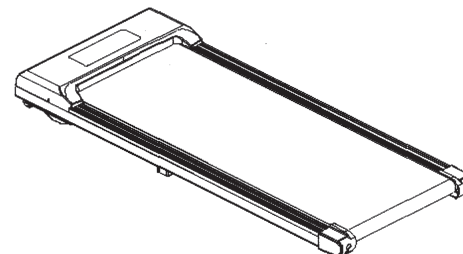

2. Use 2 screws and gaskets to fix the column hole and frame hole. (CR-A1(F) only)

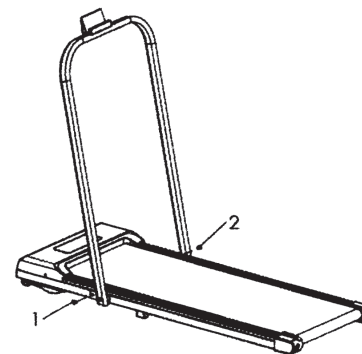

3. Plug in the power supply and use it. Use the remote controller to start the machine and adjust the speed.

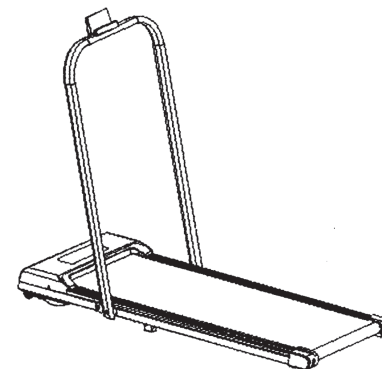

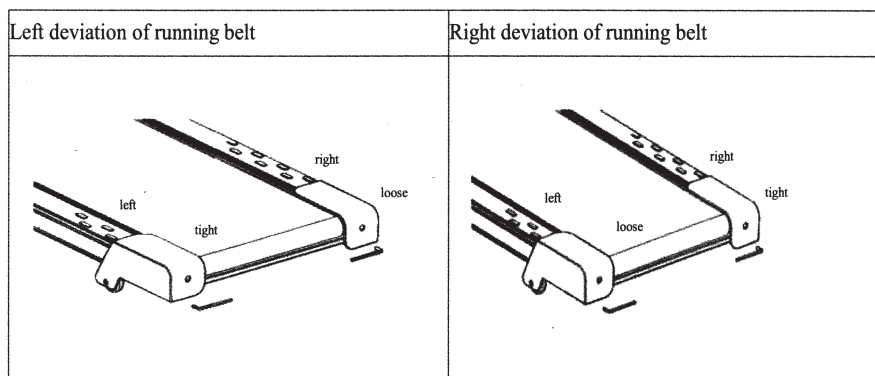

Note: Running belt deviation is not covered by warranty, and is mainly maintained and maintained by users according to the instructions.

The deviation will seriously damage the running belt and affect its service life. Please adjust in time when it occurs.

### Technical parameters

Types	CR-A <sub>1</sub>	CR-A <sub>1</sub> (F)
Operating Voltage	110V-50HZ	
Maximum Load	100 kg	
Outline Dimension	1215*500*114mm	1215*540*930mm
Effective Running Area	390*1030(mm)	
Continuous Output Power	0.75HP	
Speed	1-8km/h	1-8km/h
Functions	Walking / running	
Protection Level Against Electric Shock	Level I	
Peak Motor Power	3.0HP	

Note: the products will be upgraded from time to time, and the customers shall be subject to the physical products received.

◆ Do not use the power cord or plug when it is damaged or the socket of the socket is loose-otherwise it may cause electric shock, short circuit and fire.

◆ Do not damage or forcibly bend or twist the power cord. At the same time, do not place heavy objects on it and do not hold the wire I.  
— Failure to do so will result in fire or electric shock.

◆ Do not use two or more people at the same time, and be careful not to let people around you approach during use.  
— Otherwise, accidents or injuries may occur due to falls.

◆ Do not use it if you cannot express your awareness or if you cannot operate it.  
— Accidents or injuries may occur.

Avoid contact with water!

Do not drench the main body or operation part with water or beverage.

-may cause electric shock and fire.

Forbidden!

◆ People who do not exercise normally should not do violent sports suddenly.

◆ Do not use it after eating or when you are tired, just exercising or when your physical condition is abnormal.  
— May cause damage to health.

◆ This product is suitable for family use, not for schools, gymnasiums and other unspecified places with a large number of people.  
— There is a risk of injury.

Do not use while eating or doing other activities.

◆ Do not use when you feel sluggish after drinking.

-May cause accident or injury.

◆ Do not use when there are hard objects in the pants pocket.

--May cause accident or injury.

◆ Do not use with wet hands!

◆ Do not use wet hands to pull out or insert the power plug.

— May cause electric shock and injury.

Pull out the power plug!

◆ When not in use, pull out the power plug from the socket.

--Because dust and moisture will degrade the insulation, which will lead to leakage fire.

Grounding instructions!

◆ The product must be grounded. In case of malfunction of the machine, the grounding will provide the channel with the least resistance for the current, so as to reduce the risk of electric shock

◆ The product is equipped with power supply with equipment grounding conductor and grounding plug. The plug must be inserted into a proper socket that has been installed and grounded correctly in full accordance with local laws and regulations.

**DANGER!**

◆ if the grounding conductor of the equipment is not properly connected, electric shock may be caused. If you have any questions about whether the grounding of the product is correct, please entrust a professional electrician to check. Even if the plug attached to the product does not match the socket, it cannot be modified. Please entrust a professional electrician to install a suitable socket.

#### IV. sports suggestions and guidelines

##### Warm-up

5 to 10 minutes of warm-up before each use of the machine.

##### Breathing

Do not shield breathing during exercise. Breathing and action should be coordinated. If breathing is too fast, stop the exercise immediately.

##### Frequency

The same part of the muscle exercise should be 48 hours of rest, that is, every other day to train the same part.

##### Load

The weight of training is determined according to the state of individual physical training, and then the training is carried out according to the principle of gradual load. In the initial training, muscle ache is a normal phenomenon. As long as the training continues, the ache can be eliminated.

##### Diet

In order to protect the digestive system, exercise can be carried out one hour after meals. After training, eat at least half an hour later. Drink less water during exercise, especially avoid drinking a lot of water, so as not to increase the burden of heart and kidney.

##### stretching exercise

No matter how fast you run, it's better to stretching first. Warm muscles are easier to stretching because

5-10 minutes to warm up. Then stop and do five stretchings as follows, each leg

Do it 10 seconds or more at a time, and do it again at the end of the workout.

##### 1. Downward stretching

Slightly bend your knees, slowly bend down, relax your back and shoulders, and do your hands

Measure and touch toes, hold for 10-15 seconds, then relax, repeat 3 times

(see Figure 1)

##### 2. Hamstring stretching

Sit on a clean cushion and straighten one leg. Put the other leg in,

Keep it close to the inside of the outstretched leg and try to touch the toes with your hands,

Hold for 10-15 seconds, then relax, repeat for 3 times on each leg (see Figure 2)

##### 3. Calf and heel tendon stretching

Stand with two hands on the wall or table, one foot behind. Keep back legs upright and heels

Land, lean towards the wall or table, hold for 10-15 seconds, then

Relax, repeat each leg three times

(see Figure 3)

##### 4. Head muscle stretching

Hold the balance with your right hand on the wall or table, then extend your left hand backward, grasp your left ankle and slowly pull it up to your hip until you feel the muscle in front of your thigh is very tense, pull it up for about 10-15 seconds, then relax, and repeat for 3 times for each leg (see Figure 4)

##### 5. Sartorius muscle(muscle inside thigh) stretching

With the feet facing each other, sit down with the knees facing out, grasp the feet with both hands and pull them towards the ventral groove, hold the scrofula for 10-15 seconds, then relax and repeat for 3 times. (see chart 5)

#### V. Product instructions

##### (I) Window and Keys Description:

1. LED window displays the following functions:

A. speed window: 1. (CR-A)(F) display speed range: 1.0-6

##### (II) Second. Profile

The functions of the electronic watch

Remote control

Use function of safe lock:

Place the ferromagnetic absorption part of the safety lock belt in the yellow area, use the locker patch fitting and clip it to the front of the clothes.

• With the circumstance of power on and safety lock in the right place, stop the treadmill with sudden stop function .

##### (III)brief introduction

Functions of this electronic meter

• Remote control function

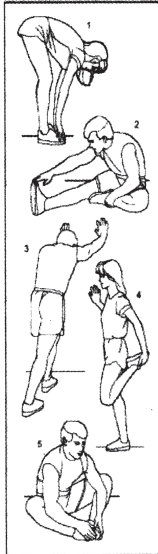

#### (IV) led display description

Display content on LED:

- Speed display
- Calorie display
- Time display

Window switch speed every 5 seconds, calories, time, display.

#### (V) function description of remote control button

Remote keypad function key:

- Start key / stop key
- speed + key
- Speed one key

#### (VI) function and operation instructions of remote control button

1. Start key / stop key - turn on the power switch on the treadmill and press the start key / stop key on the remote control when you hear a beep from the buzzer

To start running, stop the treadmill and press the start / stop key on the remote control to turn off the treadmill.

2. Speed + key: to speed up the treadmill when the treadmill is running, press the speed + on the remote control to increase 3

3. Speed key: when the treadmill is running, press the speed key on the remote control to reduce the speed of the treadmill.

#### Vi. Maintenance

##### 1. Lubrication

After using the running belt for a period of time, it is necessary to use special Jian oil for Jian sliding.

The recommended lubrication time is:

Lubricating once every 5 months for the use of less than 3 hours per week.

Lubricating once every 2 months for the use of 4-7 hours per week.

Lubricating once every month for the use of more than 7 hours per week.

Note: do not add too much dose each time.

##### 2. Check whether lubrication is required

Grasp the running belt, and touch the back central area of the running belt as much as possible. If there is silicone oil on the belt (or it feels a little wet), it means no lubrication is needed. If you feel that the running board is dry and there is no silicone oil on your hand, you need to add oil and lubricate the watch.

Measure the center position of the running belt (refer to the right figure) and spray silicone oil on the inside of the running belt. After that, run the treadmill at a speed of 1km to evenly smear silicone oil, and light the running belt from left to right. After about a minute, silicone oil will be absorbed by the running belt.

##### 3. Elastic adjustment of running belt

All treadmills have adjusted the running belt's tension before they leave the factory, but after a period of use, the running belt will still be loose. The specific form of expression is: running in normal use with a stop slip phenomenon. When this happens, adjust the running belt adjusting bolt left and right synchronously according to the clockwise direction with half a circle as the unit.

Note: when adjusting the running belt, it is not allowed to adjust the running belt too tightly, which shall be subject to the normal use of running belt without slipping. If the running belt is adjusted too tightly, the aging of the running belt will be accelerated, the motor load will be increased, and the service life of the bearing will be shortened.

##### 4. Deviation adjustment of running belt

All treadmills have adjusted the running belt deviation before they leave the factory, but after a period of use, the running belt deviation may occur, which may be caused by the following situations:

- (1) the main part is not placed stably.
- (2) the user's feet are not in the center of the running belt when exercising.
- (3) uneven force on the user's feet.

The deviation caused by human factors will automatically return to normal after several minutes of no-load operation. For some deviation phenomena that cannot be recovered automatically, adjust the belt adjusting screw by half a turn, and the specific operation is as follows:

