

Instruction Manual

EARTH AUGER



Please read this instruction manual carefully and know the operation before using this earth auger and keep this manual handy.



Detail information for engine:

Engine Model	1E44F-5/5B	1E48F	1E50F	1E53F
Displacement (CC)	49CC/52CC	65cc	71cc	81cc
Max Power (kw/r/min)	2.5HP/8000rpm	3.4HP/8500rpm	3.4HP/8500rpm	3.4HP/8500rpm
Max Torque (N.m/r/min)	2.5	3.4	3.5	3.4
Starting System	Re-coil	Re-coil	Re-coil	Re-coil
Cooling System	Air-cool	Air-cool	Air-cool	Air-cool
Fuel Mixed Ratio	Gasoline(25):2 cycle oil(1)	Gasoline(25):2 cycle oil(1)	Gasoline(25):2 cycle oil(1)	Gasoline(25):2 cycle oil(1)
Fuel Tank Capacity (L)	1.2	1.5	1.5	1.5
Drill Bit Dimension, Height	80CM/100CM	80CM/100CM	80CM/100CM	80CM/100CM
Diameter	40MM,60MM,80MM,100MM,120MM,150MM	40MM,60MM,80MM,100MM,120MM,150MM,200MM	40MM,60MM,80MM,100MM,120MM,150MM,200MM,250MM,300MM	40MM,60MM,80MM,100MM,120MM,150MM,200MM,250MM,300MM,400MM

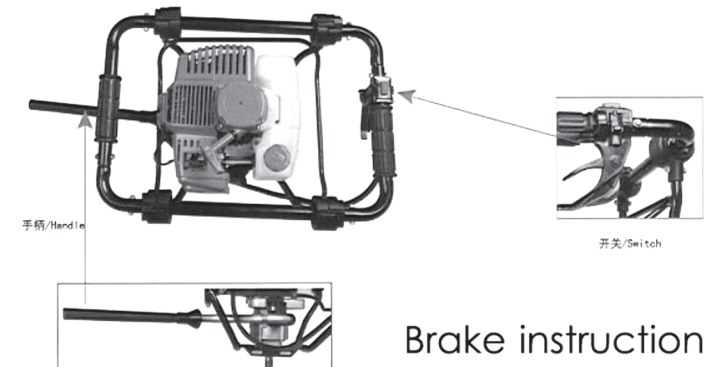
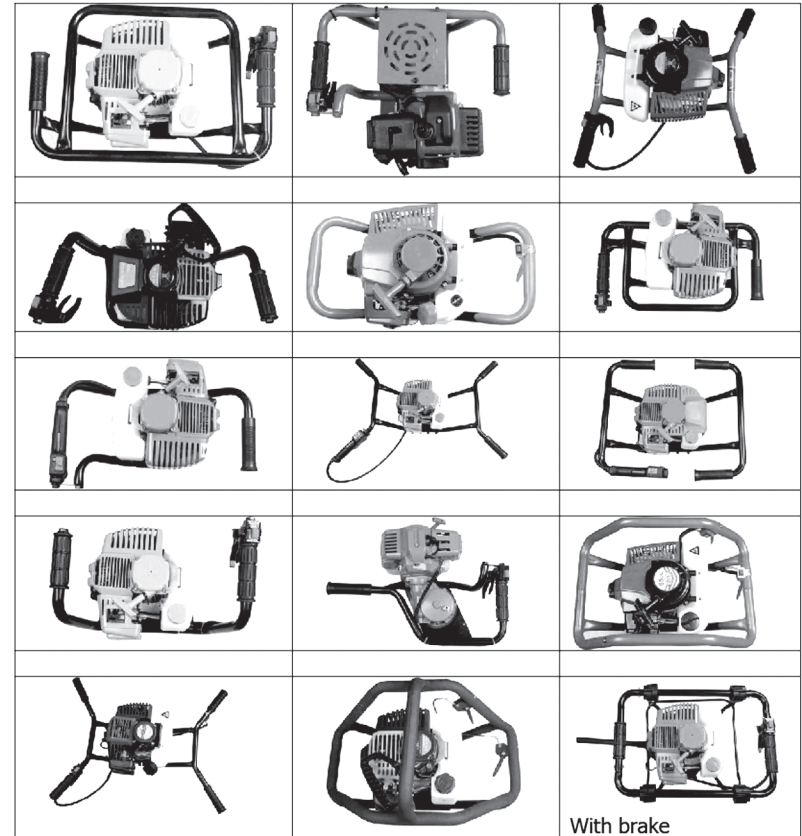

CONTENTS

Registration.....	2
Important Safety Precautions.....	3-6
Pre-Operation.....	6
Operation.....	7-8
Maintenance and Storage.....	8-10
Service, Troubleshooting and Repair.....	10-11

REGISTRATION AND SERVICE

Record the product model number and serial number in the space provided for easy reference when ordering parts or requesting technical support. Excluding emissions-related warranty items, the warranty is valid only if the completed registration is received by Viper within 30 days of purchase. (SEE WARRANTY SECTION FOR MORE INFORMATION.)

OWNERSHIP RECORDS		
Place of Purchase:		
Place of Purchase Address:		
City:	State/Province:	Zip Code/Postal Code:
Model Number:		Serial Number (found next to warning tag):
Date of Purchase:		
Notes:		

This manual may contain information for several models. Read and keep this manual for future reference. This manual contains important information on SAFETY, ASSEMBLY, OPERATION, AND MAINTENANCE. The owner must be certain that all the product information is included with the unit. This information includes the MANUAL, the REPLACEMENT PARTS and the WARRANTIES. This information must be included to make sure state laws and other laws are followed. This manual should remain with the unit even if it is resold.

ORDERING REPAIR PARTS

Parts may be obtained from the store where your auger was purchased or direct from the factory. To order from the factory, call, e-mail, or order, please contact us.

Please include the part numbers, part description, quantity, model number and serial number.

TROUBLESHOOTING:

PROBLEM	POSSIBLE CAUSE	REMEDY/ACTION
Engine will not start	1. Power switch off	1. Flip switch to ON position
	2. Spark plug wire disconnected	2. Connect spark plug wire to spark plug
	3. Out of fuel	3. Refuel
	4. Spark plug wet, faulty or improperly gapped	4. Clean, replace or gap spark plug
Engine runs rough, floods during operation	1. Dirty air filter	1. Clean or replace air filter
	2. Choke partially engaged	2. Turn off choke
	3. Carburetor out of adjustment	3. Call factory
Engine is hard to start	1. Stale fuel	1. Drain old fuel and replace with fresh. Always use gas stabilizer
	2. Spark plug wire loose	2. Make sure spark wire is securely attached to spark plug
	3. Dirty carburetor	3. Clean carburetor, use gas stabilizer, new gas can
Engine misses or lacks power	1. Clogged fuel filter	1. Remove and clean or replace
	2. Clogged air filter	2. Remove and clean or replace
Auger turns at idle	1. Idle speed too high	1. Adjust idle speed lower
	2. Broken clutch spring	2. Replace both springs
Auger turns, but has no power	1. Choke on	1. Turn off choke after engine is running
	2. Carburetor out of adjustment	2. Call factory
	3. Broken transmission	3. Call factory
	4. Worn clutch shoes	4. Replace clutch shoes and springs
Auger jumps on the ground	1. Blades damaged or sharpened incorrectly	1. Replace with new blades
Auger cuts slowly	1. Dull blades	1. Buy new blades
	2. Damaged point	2. File point, or replace point

TRANSPORTING YOUR EARTH AUGER

1. Never transport engine inside an enclosed space or vehicle. Fuel or fuel vapors may ignite causing serious injury or death.
2. If fuel is present in the fuel tank, transport in an open vehicle in an upright position with the gas cap facing upwards.
3. If an enclosed vehicle must be used, remove gas into an approved red fuel container. **DO NOT siphon by mouth.**
4. Run engine to use up the fuel in the carburetor and fuel tank. Always run engine in a well ventilated area.
5. Wipe away any spilled fuel from engine and earth auger. Allow to dry.

LONG-TERM STORAGE

- If your auger will not be run for more than one month, prepare it for long-term storage.

Steps for Long Term Storage

1. Add fuel stabilizer according to manufacturer's instructions.
2. Run engine for 10-15 minutes to ensure that the stabilizer reaches the carburetor.
3. Remove the remainder of the fuel from the gas tank into an approved fuel container.
4. Remove auger from powerhead and apply a thin layer of grease to the output shaft.
5. Store auger and powerhead (engine) in a vertical position.
6. Remove all debris from auger and powerhead (engine).
7. Attach blade protector to bottom of auger.

SERVICE, TROUBLESHOOTING AND REPAIR

SERVICE INFORMATION

The guide will help you pinpoint the causes of common problems and identify remedies.

For more complicated repairs, you may want to rely on your retailer or an authorized repair center (contact your retailer for a list of authorized mechanics in your area).

We will always be glad to answer any questions you have, or help you find suitable assistance. To order parts or inquire about warranty, call or write us at the address found on the next page,

CAUTION

AVOID INJURY! AUGER BLADES AND POINT ARE EXTREMELY SHARP. USE CAUTION WHEN REMOVING AND REPLACING.

PRACTICE SAFETY AT ALL TIMES. ENGINE MUST BE TURNED OFF AND ALLOWED TO COOL, AND SPARK PLUG WIRE MUST BE DISCONNECTED BEFORE ATTEMPTING ANY MAINTENANCE OR REPAIR.

under the section "ordering repair parts".

ICE POINT REPLACEMENT (SEE FIGURE 1 ABOVE)

1. Remove blade protector and both blades.
2. Remove nut and retaining bolt from point.
3. Using a locking pliers, grasp point and pull out. If holder doesn't come out with the point, remove with pliers.
4. With locking pliers, push in new point and holder aligning bolt hole in point with holes in auger shaft. **DO NOT damage end of point.**
NOTE: When installing holder in auger shaft, edges of holder may shave off.
5. Insert retaining bolt and tighten with nut.
6. Re-attach both blades and put blade protector back on.

WARNINGS AND SAFETY PRECAUTIONS

OPERATOR'S RESPONSIBILITY

Accurate, safe and effective use of this unit is the operator's responsibility.

- Read and follow all safety instructions.
- Carefully follow all assembly instructions.
- Maintain the unit according to directions and schedule included in this operator's manual.
- Ensure that anyone who uses the unit is familiar with and understands all controls and safety precautions.

SAFETY MESSAGES

Your manual contains special messages to bring attention to potential safety concerns, engine damage as well as helpful operating and servicing information. Please read all the information carefully to avoid injury and damage to the unit.

NOTE: General information is given throughout the manual that may help the operator in the operation or service of the unit.

 This symbol points out important safety instructions which if not followed could endanger your personal safety.

BEFORE OPERATING:

WARNING

READ ENTIRE OPERATING AND MAINTENANCE INSTRUCTIONS FOR THIS PRODUCT AND THE INSTRUCTIONS FOR THE EQUIPMENT THIS ENGINE POWERS. FAILURE TO FOLLOW INSTRUCTIONS COULD RESULT IN SERIOUS INJURY OR DEATH. OPERATE THE ENGINE ACCORDING TO THE SAFETY INSTRUCTIONS OUTLINED HERE AND INSERTED THROUGHOUT THE TEXT. ANYONE WHO USES THIS UNIT MUST READ THE INSTRUCTIONS AND BE FAMILIAR WITH THE CONTROLS.

WARNING

WARNING INDICATES A HAZARD WHICH, IF NOT AVOIDED, COULD RESULT IN DEATH OR SERIOUS INJURY AND/OR PROPERTY DAMAGE.

CAUTION

CAUTION INDICATES YOU CAN BE HURT OR YOUR EQUIPMENT DAMAGED IF THE SAFETY INSTRUCTIONS THAT FOLLOW THIS SIGNAL WORD ARE NOT OBEYED.

IMPORTANT

INDICATES HELPFUL INFORMATION FOR PROPER ASSEMBLY, OPERATION, OR MAINTENANCE OF YOUR EQUIPMENT.

WARNING

FAILURE TO COMPLY WITH ALL SAFETY AND OPERATING INSTRUCTIONS CAN RESULT IN LOSS OF ENGINE CONTROL, SERIOUS PERSONAL INJURY TO YOU AND/OR BYSTANDERS, AND RISK OF EQUIPMENT AND PROPERTY DAMAGE.

SAFETY DECALS:

Below are three of the warning decals attached to the auger. It is important to read all safety precautions and locate the warning labels before using this product.

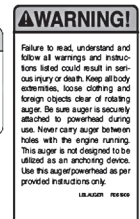
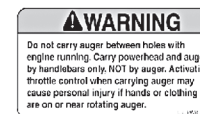

IMPORTANT SAFETY PRECAUTIONS:

- Do not carry the unit between holes with the engine running.
- The auger should not rotate when the engine is idling. If it does rotate when engine is idling, contact an Eskimo-authorized service center for instructions.
- Always keep hands, feet, hair and loose clothing away from any moving parts on engine and auger.
- Do not allow children to operate this unit! Do not allow adults to operate the unit without proper instruction.
- Do not operate any power equipment under the influence of alcohol or drugs.
- Keep all screws, nuts and bolts tight.
- Engine should be turned off and cool, spark plug wire must be removed from spark plug before any repairs are attempted.
- Temperature of muffler and nearby areas may exceed 150° F (65° C). Avoid these areas.
- Never run engine indoors or in an enclosed area. Engine exhaust contains carbon monoxide, an odorless and deadly gas.
- If the auger becomes unturnable in a hole, turn engine off and allow to cool before attempting to remove it manually.

ENGINE SAFETY PRECAUTIONS

Preventing Carbon Monoxide Poisoning

- Never try to ventilate engine exhaust indoors. Carbon monoxide can reach dangerous levels very quickly.
- Never run engine outdoors where exhaust fumes may be pulled into a building.
- Never run engine outdoors in a poorly ventilated area where the exhaust fumes may be trapped and not easily taken away. (Examples include: in a large hole or areas that are covered by snow drifts.)
- Never run engine in an enclosed or partially enclosed area. (Examples include: buildings that are enclosed on one or more sides, inside shelters, garages or basements.)
- Always run the engine with the exhaust and muffler pointed in the direction away from the operator.
- Never point the exhaust muffler towards anyone. People should always be many feet away from the operation of the engine and its attachments.
- Do not change the engine governor settings or over-speed the engine.
- Stay away from rotating parts. Place protective covers over rotating parts.

WARNING

ENGINES GIVE OFF CARBON MONOXIDE, AN ODORLESS, COLORLESS, POISONOUS GAS. CARBON MONOXIDE MAY BE PRESENT EVEN IF YOU DO NOT SMELL OR SEE ANY ENGINE EXHAUST. BREATHING CARBON MONOXIDE CAN CAUSE NAUSEA, FAINTING OR DEATH, IN ADDITION TO DROWSINESS, DIZZINESS AND CONFUSION.

IF YOU EXPERIENCE ANY OF THESE SYMPTOMS, SEEK FRESH AIR AND MEDICAL ATTENTION IMMEDIATELY.

START AND RUN ENGINE OUTDOORS. DO NOT START OR RUN ENGINE IN AN ENCLOSED AREA, EVEN IF DOORS OR WINDOWS ARE OPEN.

WARNING

DO NOT ALTER/MODIFY ENGINE:

NEVER ALTER OR MODIFY THE ENGINE FROM THE FACTORY. SERIOUS INJURY OR DEATH MAY OCCUR IF ENGINE IS MODIFIED OR ALTERED.

WHEN WORKING ON OR REPLACING PARTS FOR THE ENGINE OR PRODUCT, YOU MUST ALWAYS DISCONNECT SPARK PLUG WIRE FROM THE SPARK PLUG AND KEEP IT AWAY FROM THE SPARK PLUG.

ALWAYS WEAR HEARING PROTECTION WHILE OPERATING ENGINE.

PLEASE DO NOT START YOUR ICE AUGER UNTIL YOU HAVE READ THE PREVIOUS SECTION OF THIS MANUAL. IF YOU HAVE READ THESE, FOLLOW THE STEPS ON THE NEXT PAGE TO START YOUR ICE AUGER.

NEVER STORE ENGINE WITH GAS IN THE TANK INDOORS. FUEL AND FUEL VAPORS ARE HIGHLY FLAMMABLE.

NEVER MIX FUEL AND OIL DIRECTLY IN ENGINE GAS TANK. USE ONLY NON-METAL, PORTABLE FUEL CONTAINERS APPROVED BY THE UNDERWRITER'S LABORATORY (U.L.) OR THE AMERICAN SOCIETY FOR TESTING & MATERIALS (ASTM).

HANDLING AND FILLING THE ENGINE WITH FUEL MUST ALWAYS BE DONE BY AN ADULT.

ALWAYS HANDLE FUEL IN A WELL VENTILATED AREA, OUTDOORS, AWAY FROM FLAMES OR SPARKS.

- Do not use engine around dry brush, cloth rags, or other flammable materials.
- Always keep materials and debris clear of muffler guard and other hot engine parts.

a maintenance schedule, routine inspection procedures, and simple maintenance procedures using basic hand tools.

Other service tasks that are more difficult, or require special tools, are best handled by professionals and are normally performed by a technician or other qualified mechanic.

Maintenance, replacement or repair of the emissions control devices and systems may be performed by any non-road engine repair establishment or individuals. However, all authorized warranty repairs must be handled by an authorized service center.

The maintenance schedule applies to normal operating conditions. If you operate your engine under unusual conditions, such as sustained high-load or high-temperature operation, or use in unusually wet or dusty conditions, consult your servicing dealer for recommendations applicable to your individual needs and use.

Cooling Fins

Cooling fins, air inlets and linkages must be free from any debris before each use.

Air Filter

Never run engine without air cleaner properly installed. Added wear and engine failure may occur if air cleaner is not installed on engine.

Steps for Cleaning Air Filter

1. Wash in warm water with mild soap until dirt and debris are removed. Press filter when washing, do not twist.
2. Rinse in warm water until soap and dirt are removed.
3. Dry filter by wrapping in a clean cloth and pressing filter until it is dry.
4. Attach the filter and air cleaner cover to the engine.

MAINTENANCE ITEM

		Every 8 hours (daily)	Every 20 hours or seasonally	Yearly
Clean Engine and Check Bolts and Nut		X		
Air Filter (See Air Filter section)	Check	X		
	Clean *		X	
Spark Plug (Gap .028") (See Spark Plug section)	Replace		X	X
	Check/Adjust		X	
	Replace			X

CAUTION

AVOID INJURY! TO AVOID INJURY OR DEATH, NEVER SIPHON FUEL BY MOUTH.

AVOID INJURY! NEVER STORE ICE AUGER WITH FUEL IN THE GAS TANK INSIDE AN ENCLOSED AREA OR BUILDING.

Spark Plug

The recommended spark plug is NGK BM6A. (33cc, 43cc and 51 cc engines) or NGK BPMR7A (71 cc engines)

1. Check spark plug every 50 operating hours.
2. Disconnect the spark plug cap, and clean any debris from around the spark plug area.
3. Remove spark plug and replace if any of the following occur; pitted electrodes, burned electrodes, cracked porcelain, or deposits around electrodes.
4. After analysis, seat spark plug and tighten with spark plug wrench.
 - Reinstall original spark plug, tighten additional 1/2 turn.
 - Installing new spark plug, adjust spark plug gap to .028" and tighten additional 1/8 – 1/4 turn .

NOTE: A loose spark plug may overheat and damage engine. An over tightened spark plug may damage threads in the cylinder head.

(Cold Engine Start, continued from page 7)

- Prime unit until primer tube is filled with gas.
NOTE: When using the primer bulb, allow the bulb to return completely to its original position between pushes.
- Move choke lever to **CHOKE** or **ON** position.
NOTE: CHOKE position is defined by moving the choke lever as far to the ON position as possible.
- Push engine switch to the **ON** position.

- Grasp starter handle with left hand and pull out slowly, until there is tension as you pull. Without letting starter handle retract, pull rope with a rapid full arm stroke. **Let it return to its original position very slowly** until the engine fires or runs, engage the throttle. **When attempting to start, DO NOT allow the recoil to retract on its own, as it may snap back quickly and cause injury.** Repeat this step every time the starter rope is pulled.

NOTE: If engine fails to start after 5-6 pulls, push primer 1 time and pull starter rope again.

- After engine starts running, move choke lever to **HALF CHOKE** position until unit runs smoothly.
NOTE: HALF CHOKE is defined when the choke lever is between CHOKE and RUN or ON and OFF.
- Move choke lever to **RUN** or **OFF** position and move throttle to desired speed.

NOTE: Run at full throttle when possible. Do not let unit idle for extended periods of time.

- To stop engine, push engine switch to **OFF** position.

Warm Engine Start:

- Move choke lever to **CHOKE** or **ON** position.
NOTE: CHOKE position is defined by moving the choke lever as far to the ON position as possible.
- Continue with Step 5 of Cold Engine Starting.

MAINTENANCE AND STORAGE

AUGER MAINTENANCE

- The gear case has 4 oz. of lithium grease installed at the factory. It is recommended that once a year the gear case be split and the grease level checked. Add grease only if level of grease is below top of the gears. **DO NOT OVERFILL.**
- Keep all screws, nuts, and bolts tight.
- For cold weather operation, store the unit in a cool environ-

CAUTION

AVOID INJURY! DO NOT ATTEMPT TO START THE ENGINE USING STARTING FLUID.

AVOID INJURY! DO NOT SPRAY FLAMMABLE LIQUIDS OR VAPORS INTO AIR CLEANER, CARBURETOR OR SPARK PLUG CHAMBER.

AVOID INJURY! DO NOT REMOVE SPARK PLUG AND PULL STARTER ROPE. FLAMMABLE FUEL CAN SPRAY OUT & IGNITE FROM A SPARK FROM SPARK PLUG.

CAUTION

TO PREVENT ACCIDENTAL STARTING:

AVOID INJURY! ENGINE MUST BE TURNED OFF AND COOL, AND SPARK PLUG WIRE MUST BE REMOVED FROM SPARK PLUG BEFORE CHECKING AND ADJUSTING ENGINE OR EQUIPMENT.

AVOID INJURY! TEMPERATURE OF MUFFLER AND NEARBY AREAS MAY EXCEED 150° F (65° C). AVOID THESE AREAS.

AVOID INJURY! CHECK AUGER OFTEN FOR LOOSE NUTS AND BOLTS. KEEP THESE ITEMS TIGHTENED.

AVOID INJURY! NEVER STORE ENGINE WITH FUEL IN THE TANK INSIDE A BUILDING. POTENTIAL SPARKS MAY BE PRESENT FOR IGNITION OF FUEL AND FUEL VAPORS.

AVOID INJURY! AN ADULT MUST ALWAYS DO MAINTENANCE AND REPAIR ON ENGINE AND AUGER.

AVOID INJURY! ENGINE MUST BE SHUT-OFF, COOL, AND SPARK PLUG WIRE REMOVED BEFORE ANY REPAIR OR MAINTENANCE CAN BE DONE.

ment. Transferring the unit from a warm to a cold place can cause the build up of harmful condensation.

- Always replace blade protector when power auger is not in use.
- If blade performance decreases, turn unit off and disconnect spark plug wire. Carefully inspect cutting edge of blades for any nicks or shiny areas. If blades show any of these signs, they need to be resharpened or replaced.

ENGINE MAINTENANCE

Please read the maintenance schedule and observe these recommendations to extend the life of your engine.

Good maintenance is essential for safe, economical, and trouble-free operation. It will also help reduce air pollution. To help you properly care for your engine, the following pages include

- Never operate the engine without the muffler guard in place.
- Always make sure the exhaust pipe is free of foreign objects.
- The engine exhaust becomes very hot during operation. Keep engine at least three feet away from buildings and other equipment during operation.
- Wear appropriate clothing such as a long-sleeved shirt or jacket. Also wear long trousers or slacks. Do not wear open shoes, and never operate the machine with bare feet.
- Do not wear loose clothing or jewelry. They can get caught in moving parts. Always keep hands, feet, hair and loose clothing away from any moving parts on engine and machine.
- Always run the engine with fuel cap properly installed on the engine.
- Never smoke while refilling engine fuel tank.
- Do not store engine with fuel in fuel tank indoors. Fuel and fuel vapors are highly explosive.
- During storage, tightly screw down fuel cap.
- Never pour fuel from engine fuel tank.
- Never siphon fuel by mouth to drain fuel tank.
- Always have an adult fill the fuel tank and never allow children to fill the engine.
- Never allow an adult or anyone under the influence of drugs or alcohol to fill engine.
- When storing gasoline or equipment with fuel in the tank, store away from furnaces, stoves, water heaters or other appliances that have a pilot light or other ignition source because they can ignite gasoline vapors.

Gasoline Fires and Handling Fuel Safely

Use extra care in handling gasoline and other fuels. They are flammable and vapors are explosive.

- Never fill your fuel tank with fuel indoors. (Examples include: basement, garage, barn, shed, house, porch, ice shelter, etc.)
- When storing extra fuel be sure that it is in an appropriate container and away from any fire hazards.
- Always fill fuel tank outside in a well ventilated area. Never fill your fuel tank with fuel indoors. (Examples include: basement, garage, barn, shed, house, porch, etc.) Never fill tank near appliances with pilot lights, heaters, or other ignition sources. If the fuel has to be drained, this should be done outdoors and with the proper equipment. Do not pour fuel from fuel tank. The drained fuel should be stored in a container specifically designed for fuel storage or it should be disposed of carefully.
- Never remove the fuel cap or add fuel with the engine running. Stop engine and allow to cool before removing the fuel cap/and or refilling the engine.
- Do not smoke near or while handling engine fuel.
- Never drain fuel from engine in an enclosed area.
- Always wipe up excess (spilled) fuel from engine before starting. Clean up spilled fuel immediately. If fuel is spilled, do not start the engine but move product and fuel container away from the area. Clean up spilled fuel and allow to evaporate and dry after wiping and before starting.
- Allow fuel fumes/vapors to escape from the area before starting engine.
- Test the fuel cap for proper installation before starting and using engine.

BURNS AND FIRES

The muffler, muffler guard and other parts of the engine become extremely hot during the operation of the engine. These parts remain extremely hot after the engine has stopped.

Prevention of Burns and Fires

- Never remove the muffler guard from the engine.
- Never touch the muffler guard because it is extremely hot and will cause severe burns.
- Never touch parts of the engine that become hot after operation.
- Always keep materials and debris away from muffler guard and other hot parts of the engine to avoid fires.

SERVICE

- Always stop the engine whenever you leave the equipment, before cleaning, repairing or inspecting the unit. Engine should be turned off and cool, spark plug wire must be removed from spark plug before any repairs or adjustments are attempted. Never make adjustments or repairs with the engine (motor) running. Disconnect the spark plug wire, and keep the wire away from the plug to prevent accidental starting.
- Always wear eye protection when you make adjustments or repairs.
- Keep all nuts and bolts tight and keep equipment in good condition.
- Never tamper with safety devices. Check their proper operation regularly.

(SERVICE, continued on page 6)

(SERVICE, continued from page 5)

When servicing or repairing the engine, do not tip the engine over or up unless specifically instructed to do so in this manual. Service and repair procedures can be done with the engine in an upright position. Some procedures will be easier if the engine is lifted on a raised platform or working surface.

- To reduce fire hazard, keep engine free of debris build-up. Clean up oil or fuel spillage. Allow engine to cool before storing.
- Stop and inspect the equipment if you strike an object. Repair, if necessary, before restarting.
- Clean and replace safety and instruction decals as necessary.
- To guard against engine over-heating, always have engine debris filter mounted and clean.
- Inspect engine before storage. When not in use, disconnect spark plug lead and store indoors in a dry place locked or otherwise inaccessible to children.
- Use only original equipment parts.

PRE-OPERATION

STEPS FOR WORKING ON ENGINE OR AUGER

1. Turn off engine switch.
2. Disconnect the spark plug wire from the spark plug.
3. Securely place the disconnected spark plug wire away from the spark plug and any metal parts. This must always be done or arcing may occur between spark plug wire and metal parts.
4. Replace or repair the part on the engine or auger.
5. Check all parts that were repaired, or removed during repair, that they are secure and fit correctly.

NOTE: All repair parts must come from the factory. Never replace parts that are not specifically designed for the engine or auger.

6. Reconnect spark plug wire to the spark plug.

PREPARING ENGINE FOR STARTING

Before starting your unit, make sure the black throttle cable housing is seated all the way into the brass ferrule at the engine side of the cable.

GAS AND OIL

Quality

To operate the engine, we recommend using Viper® brand 2-cycle oil (P/N 300400) to ensure that the engine operates correctly throughout the life of the engine. Viper® brand 2-cycle oil has fuel stabilizer additive which helps to prevent gasoline from oxidizing and gumming up the carburetor when the unit is not

IMPORTANT

THIS ENGINE USES A GAS/OIL MIXTURE. DO NOT RUN ON STRAIGHT GAS ONLY, ENGINE DAMAGE WILL RESULT.

in use for long periods of time. Use unleaded regular gas only. It is best to use premium gasoline that has no ethanol content.

Mixture

Run ice auger with a 50:1 ratio.

GAS	OIL	RATIO
1 gallon	2.5 ounces	25:1
2 gallons	5 ounces	25:1
5 gallons	13 ounces	25:1

MIXING FUEL AND FILLING FUEL TANK

Mixing Fuel

1. Fuel must be mixed in a container outside in a well ventilated area.
2. Fill certified fuel container 1/4 full of recommended fuel.
3. Add recommended amount of 2 cycle oil with fuel stabilizer.
4. Screw container cap on straight and tight.
5. Shake the container to mix fuel and oil.
6. Wipe away any spilled fuel or oil and allow to evaporate before moving or transporting.

Filling Fuel Tank

1. Shut-off engine and allow engine to completely cool before refilling the fuel tank.
2. Move to a well ventilated area, outdoors, away from flames and sparks.
3. Clean debris from area around the fuel cap.
4. Loosen fuel cap slowly. Place the cap on a clean, dry surface.
5. Carefully add fuel without spilling.
6. Do not fill fuel tank completely full, allow space for fuel to expand.
7. Immediately replace fuel cap and tighten. Wipe off spilled fuel and allow to dry before starting engine.

OPERATION

1. The clutch will transfer maximum power after about two hours of normal operation. During this break-in period clutch slippage may occur. The clutch should be kept free of oil or other moisture for efficient operation.
2. Drill holes without placing body weight on the unit. The auger operates most efficiently with a shaving action caused by the weight of the unit itself.
3. Never run engine indoors. Exhaust fumes are deadly.
4. To attach the auger to the powerhead, in the event this has not been done, align hole at top of shaft with output shaft hole. Insert bolt and secure bolt with provided allen wrench.

NOTE: The ends of the bolt should be flush with auger collar. Bolt head and thread end should never go beyond ice collar.

Cold Engine Start:

Starting engine for first time or after engine has cooled off or after running out of fuel.

1. Move choke lever to **RUN** or **OFF** position.

NOTE: Choke must be in the RUN or OFF position when pushing or using the primer bulb.

(Cold Engine Start, continued on page 8)

WARNING

AVOID INJURY! MAKE SURE THE UNIT IS IN A STABLE POSITION BEFORE PULLING THE STARTER HANDLE.

AVOID INJURY! WHEN THE UNIT STARTS TO FIRE OR RUN, RELEASE THE THROTTLE CONTROL MOMENTARILY WITH YOUR RIGHT HAND AND RETURN YOUR LEFT HAND TO THE HANDLEBAR POSITION TO MAINTAIN CONTROL AND STABILITY OF THE UNIT WITH BOTH HANDS.

CAUTION

AVOID INJURY! ALWAYS HANDLE FUEL IN A WELL VENTILATED AREA, OUTDOORS, AWAY FROM FLAMES OR SPARKS.

AVOID INJURY! DO NOT START ENGINE IF FUEL IS SPILLED. WIPE OFF EXCESS FUEL AND ALLOW TO DRY. REMOVE ENGINE FROM AREA TO AVOID SPARKS.

CAUTION

AVOID INJURY! ALWAYS HANDLE FUEL IN A WELL VENTILATED AREA, OUTDOORS, AWAY FROM FLAMES OR SPARKS.

AVOID INJURY! DO NOT START ENGINE IF FUEL IS SPILLED. WIPE OFF EXCESS FUEL AND ALLOW TO DRY. REMOVE ENGINE FROM AREA TO AVOID SPARKS.

AVOID INJURY! IF AUGER IS MOUNTED TO ENGINE, ALL SAFETY GUARDS MUST BE SECURELY FASTENED TO AVOID SERIOUS INJURY.

AVOID INJURY! STARTER ROPE CAN CAUSE AN UNANTICIPATED JERK TOWARDS ENGINE. PLEASE FOLLOW INSTRUCTIONS TO AVOID INJURY.

AVOID INJURY! IF ENGINE FAILS TO START AFTER TRYING STARTING PROCEDURES, CONTACT YOUR DEALER

AVOID INJURY! NEVER LEAVE ENGINE RUNNING WHILE UNATTENDED. TURN OFF AFTER EVERY USE.

AVOID INJURY! NEVER CARRY POWERHEAD AND AUGER BETWEEN HOLES WHILE ENGINE IS RUNNING.