

CE

Quality Certification

精彩瞬间 恒久留传
BEAUTY YOUR LIFE



3D

MINI SUBLIMATION VACUUM HEAT PRESS MACHINE

说 明 书

Operating Instructions

发明专利：201310706970.9



Mini multifunction heat press machine
迷你型真空热转印机

F R E E S U B

自由烫印尽显色彩



目录

| | | |
|-------|-----------------------|-------|
| 简介 | Introduction | 02 |
| 机器图解 | Diagram | 03 |
| 外观设计 | Designs | 04 |
| 产品示意图 | Schematic of products | 05 |
| 按键操作 | Instruction of keys | 6-7 |
| 手机壳 | Phone case | 8-11 |
| 马克杯 | Mug | 12-13 |
| 异型杯 | Peculiar mug | 14-15 |
| 小酒杯 | Small wineglass | 16-17 |
| 8寸盘子 | 8 inch plate | 18-19 |
| 塑料杯 | Plastic cup | 20-21 |
| 锥形杯 | Conic mug | 22-23 |
| 功率参数 | Power parameters | 24 |

创新科技

Innovative technology

颠覆传统

subvert tradition

全新一代热转印机

New generation sublimation heat press machine

这是一种具有颠覆传统意义的热转印加工方法，MINI型3D真空转印机，以超轻的重量，娇小的体积，庞大的功能，较低的能耗，高效的转印功能，能为传统热转印市场带来革新式的改变。

This is a significant, which subverting our tradition's heat transfer printing technology. MINI 3D sublimation vacuum heat press machine, with its super low weight, small size, huge functions, low energy, efficient transfer printing, can ring a revolution to the traditional heat transfer printing market.

配合本公司生产的各种印制夹具，可以印制各种3D手机壳，同时还可以生产多达几十种的马克杯，盘子等，一机多用。请认真阅读本说明书，详细了解各种产品的印制方法。

Combining with our company's different kinds of printing fixtures, it can print various 3D phone cases, dozens of mugs, plates, and so on, one machine, multi purposes. Please read the instruction carefully, understanding the printing methods of different kinds of products detailedly.



手机壳 Phone Case
PIP5-L (M)



水壶 Kid Water Bottle
SLH-02



月光盘 plate
SCY11C



马克杯 mug
SKB01



机器图解 Diagram

- 1、功能齐全：可印30款杯子、手机壳、盘等
- 2、色彩丰富：热风循环加热，转印更清晰
- 3、品质可靠：不锈钢加热管，10万小时寿命
- 4、智能设计：数码温控，一键完成
- 5、超大容量：一台抵四台，效率极高
- 6、6KG重量：超轻巧设计不占空间
- 7、时尚外观：流线形外观设计，时尚
- 8、价格合理：物有所值，性价比极高

1. Multifunction: be available to print more than 30 kinds of mugs, phone cases, plates and so on.
2. Rich colors: heated by circulatory hot wind, picture is more distinct.
3. Reliable quality: stainless steel heating tube, with life span of 100 thousand hours.
4. Intelligent design: digital temperature control, one key to finish.
5. ultra-large capacity: one equals to four other machines, high efficiency.
6. Weihtg : 6kg, super lightweight design, save space.
7. Fashion appearance: Streamlined appearance design, fashion.
8. equitable price: most cost-effective.



整机外观设计图

MINI MULTIFUNCTION HEAT PRESS MACHINE



DESIGNS

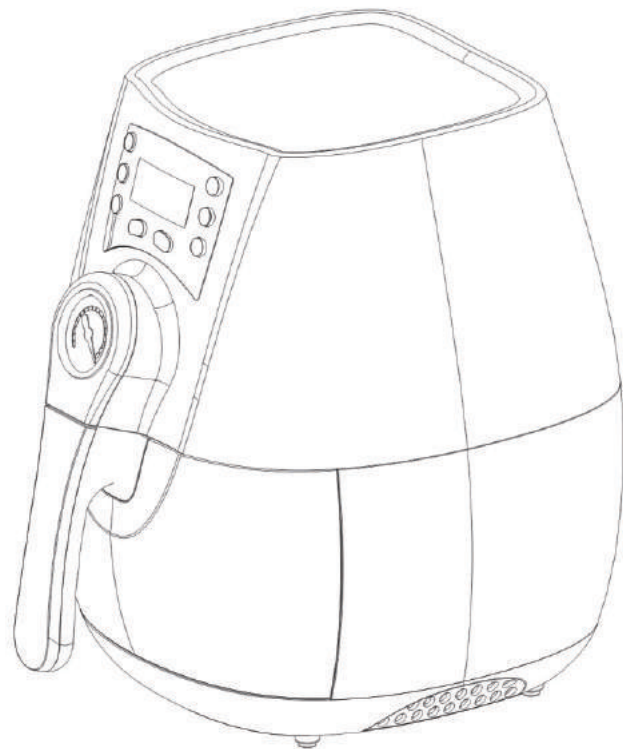

Easy good life 轻松好生活

使用本产品前，请先仔细阅读本手册，并保留说明以供日后参考
Before using this product, please read this manual carefully,
and keep instructions for future reference

产品示意图：

- 1.下壳 2.散热孔
3.锅体 4.手柄
5.盘子 6.拉手
7.电路板 8.显示屏
9.上壳 10.真空泵
11.风扇电机 12.排气孔

Schematic of products:

1. down case 2. heat dissipation hole
3. oven body 4. handle
5. plate 6. pull
7. circuit board 8. display screen
9. upper case 10. vacuum pump
11. fan motor 12. gas vent

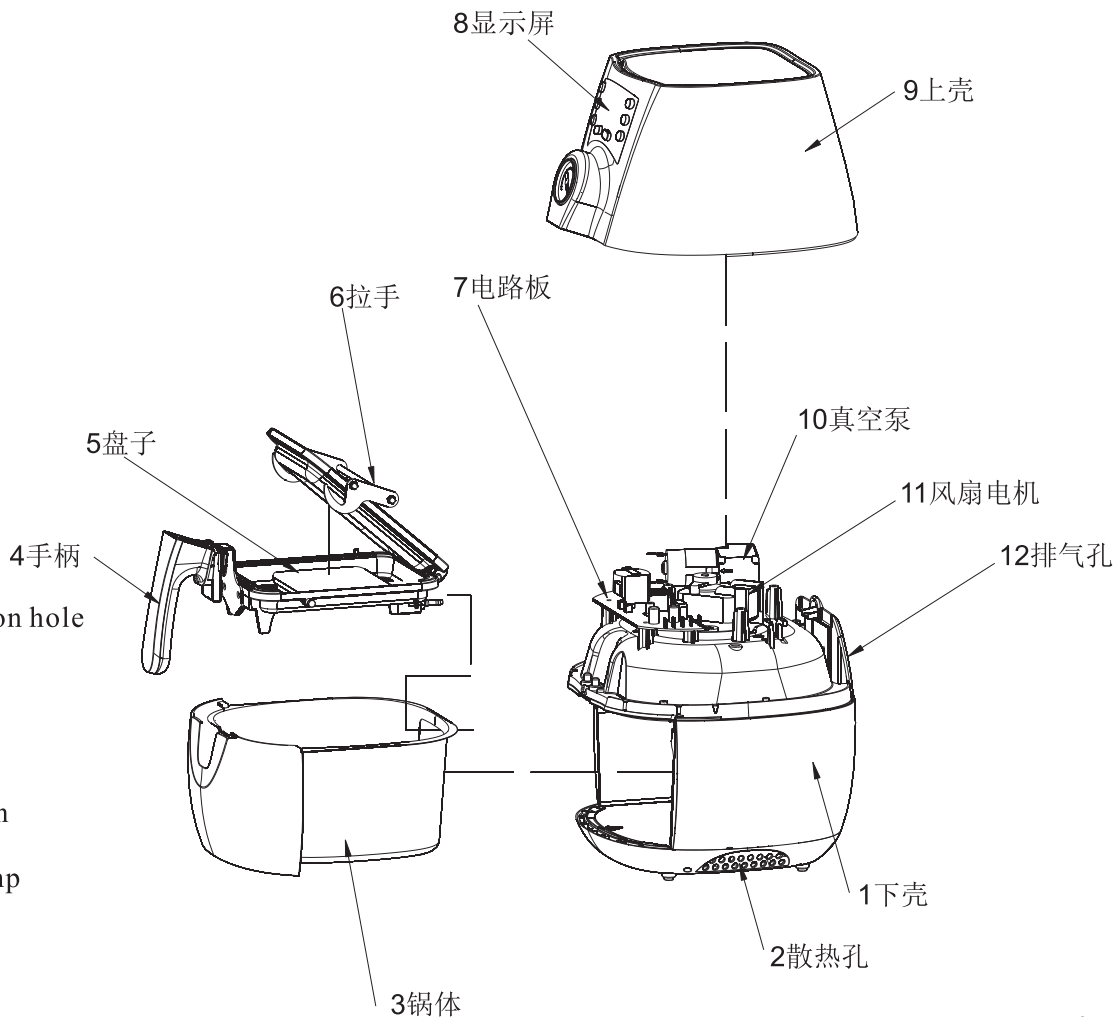

按键使用说明图 Instruction of keys:

| | | |
|--|-----------------------------|--|
|  | POWER 电源开关 | 短按一下，打开或关闭整机电源。 注（当关闭电源时风机会延时2分钟，请勿直接拔电源） |
|  | TIME SETTING 时间设置 | 短按：设置工作倒计时时间。默认为：360秒 长按5秒后：设置真空泵延时启动，主要用胶片制作手机壳时需要烘膜使用。 |
|  | TEMPERATURE 温度设置 | 短按1秒：设置机器的温度。出厂默认为：180度 长按5秒后：设置烘软胶片时的温度。该功能只有当真空泵有延时设定时才有效。出厂默认为：90度 |
|  | HEATING 加热键 | 点按一次，打开加热器，同时匀热风机也开始工作。再按一次，关闭加热器，风机二分钟后关闭 |
|  | VACUUM 真空泵 | 点按一次，打开真空泵，开始吸气，再按一次关闭真空泵。 |
|  | TIMING 倒计时 | 点按一次开始倒计时，再按一次暂停倒计时。 长按5秒后，恢复到初始设置。 |
|  | + 功能键 | 当在设置状态下，用来增加相应的参数。 长按（+）5秒钟：是否进入设置联动状态。在OFF状态时，按倒计时真空泵会同时启动。 |
|  | - 功能键 | 当在设置状态下，用来减少相应的参数。 当同时按下（+）和（-）号键时，可以在华氏度（°F）和摄氏度（°C.）之间切换。 |

ST-1520机器面贴示意图

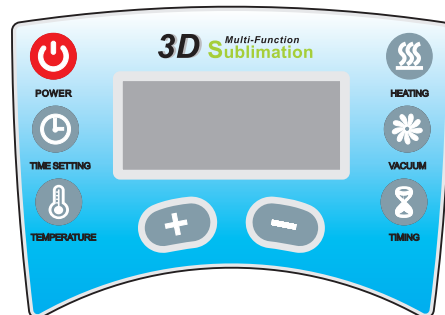





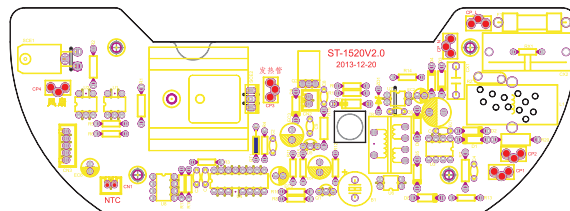



外观设计专利：201330636164.x

电路板接线示意图



- 1号AC-N：红色粗线 主进线 +级 2号AC-L：蓝色粗线 主进线 -级
- 3号CP2：蓝色细线 连接风机蓝色线 4号CP1：黑色粗线 连接发热管
- 5号CP3：蓝色粗线 连接发热管 6号CP4：黑色细线 连接风机黑色线
- 7号CN1 NTC：双黑色线温度传感器 8号CN2 PUMP:红蓝色细线 接真空泵

Instruction of keys:

| | | |
|--|--------------|--|
|  | POWER | Press it shortly,turn on or turn off the main power. Caution:when the power is off,the draught fan will delay 2 minutes.Don't unplug the power directly. |
|  | TIME SETTING | Short press: set count down time. Default time: 360 seconds. Long press 5 seconds: set the delay time of vacuum pump,used in printing phone cases with 3D film (bake the film). |
|  | TEMPERATURE | Short press 1 second: set the temperature of the machine.Default temperature:180 ℃. Long press 5 seconds: set the temperature of baking soft film.This function takes effect after setting the delay time of vacuum pump. Default temperature:90 ℃. |
|  | HEATING | Press 1 time,start the heater,and the air blower works too. Press again,shut down the heater,and the air blower shut down 2 minutes later. |
|  | VACUUM | Press 1 time,start vacuum pump,it exhausts air, press again,it shuts down. |
|  | TIMING | Press 1 time,it starts to count down,press again,it pauses,long press 5 seconds,it returns to original. |
|  | + | At the setting mode,add related parameter. Long press (+) 5 seconds: get into the mode of linked. At the OFF mode,press count down key and the vacuum pump starts too. |
|  | - | At the setting mode,reduce related parameter. Press (+)(-) at the same time,you can switch between ℉ & ℃. |

ST-1520 Schematic of display board

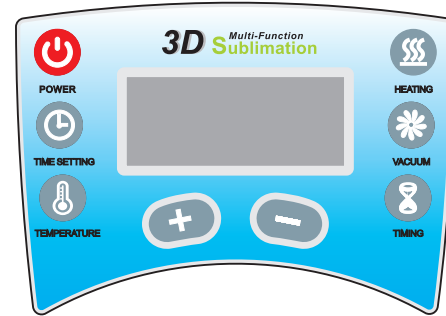

Design patent No.: 201330636164.x

Schematic of circuit board

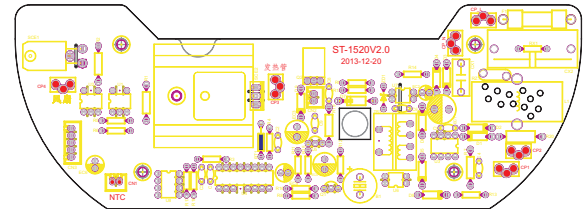

- No.1 AC-N: red thick line main coil in , positive
- No.2 AC-L: blue thick line main coil in , negative
- No.3 CP2: blue fine line connect to fan's blue line
- No.4 CP1: black thick line connect to heating tube
- No.5 CP3: blue thick line connect to heating tube
- No.6 CP4: black fine line connect to fan's black line
- No.7 CN1 NTC: double black line heat sensor
- No.8 CN2 PUMP: red and blue fine line connect to vacuum pump

手机壳热转印效果图
effect picture of sublimation phone case



手机壳转印 - 纸张打印图案

Phone cases transfer printing-paper printing image

材料:

- 1、热转印专用纸
- 2、耐高温塑料手机壳
- 3、热升华墨水
- 4、相应的手机印制工具

制作方法:

- 1、将机器升温到**190度**，首次升温应恒温2分钟。
- 2、将纸张剪切好，用耐高温胶带贴到手机壳上。
- 3、时间设置为**300秒**。
- 4、当温度达到后，把贴好纸的手机壳放入机器内。
- 5、印制**300秒**后，拿出手机壳，并放入冷却定型工具内。

常见问题:

- 1、手机壳偏小，卡不到手机上?

解决方法:降低温度到180度，时间缩短到260秒。

- 2、图案颜色不亮丽?

解决: 请确认你的纸张是否为热转印专用纸和进口墨水?

Material:

- 1.sublimation special paper
- 2.heat-proof plastic phone case
- 3.sublimation ink
- 4.related printing phone case mould

Steps:

- 1.heat up machine temperature to **190 °C**,first time use keep temperature constant for 2 minutes.
- 2.cut paper and stick it onto phone cases by heat-resistant tape.
- 3.set time as **300 seconds**.
- 4.when temperature reaches to 190°C,put phone case with paper into the machine.
- 5.after printing **300 seconds**,take out phone case and put into cooling tool and fix mould.

FAQ:

- 1.the phone case is smaller than mobile phone?

Solution: reduce temperature to 180°C,shorten time to 260 seconds.

- 2.the picture color is not colorful?

Solution: make sure your paper is sublimation special paper and ink is imported sublimation ink?



真空吸盘夹具 发明专利号: 201320845273.7
Vacuum clamp Patent for Invention No.

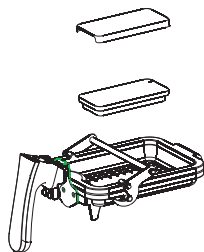

1、贴图
stick picture

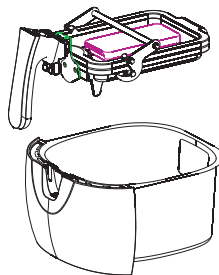

2、安装夹具
assemble clamp

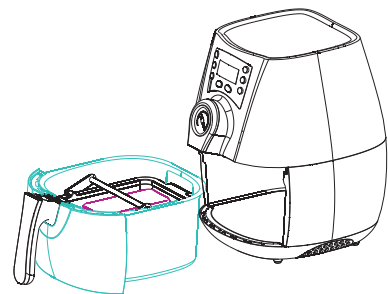

3、放入机内
put in machine

手机壳转印 - 胶片打印图案

材料：

- 1、3D热转印专用胶片
- 2、耐高温塑料手机壳或普通ABS塑料壳
- 3、普通热升华墨水或**低温升华墨水**
- 4、相应的手机印制工具

机器设置：

- 1、短按（TIME SETTING）设置时间为360秒。
- 2、长按（TIME SETTING）设置真空泵延时为20秒。
- 3、短按（TEMPERATURE）设置高温区为160度。
- 4、长按（TEMPERATURE）设置烘胶片温度为90度。
- 5、长按+号键：设置到（ON）真空泵和定时联动状态。

操作方法：

- 1、取下真空吸皮，更换胶片专用密封条。
- 3、按HEATING加热键，开始升温，首次升温只能升到90度
- 4、当温度达到后，恒温2分钟，这时手机模具应放在炉内预热。
- 5、取出水盘，安装好转印胶片，放入机器内按下TIMING计时键。

常见问题：

1、手机壳偏大或偏小，卡不到手机上？

解决：偏大把升温度到180度，偏小把温度降到150，并确认你的手机壳类型。

2、转印ABS塑料手机壳特别注意哪些？

第一：你的墨水一定要是低温墨水。

第二：温度设置要改为：高温区为：110度。烘胶片温度为：80度，时间300秒。

第三：升温时请把你的手机壳放在炉内预热。

3、胶片吸气时有漏气？

解决：更换厚一些的密封条，或在原上面密封条另加一个大头针进行固定。

或者还可以用医用胶带来加厚上面密封条。

4、胶片吸气时有破裂？

解决：1、如果是一开始吸气时就有破裂，请降低第二段烘膜温度，设为：80度。连续操作时，应拿出锅体，让炉内温度降到80度以内再放膜吸气。

2、如果是吸到最后时有破裂，请把第一段温度降到150度。



1、设置参数

高温区： 160度
烘膜温度： 90度
真空泵延时： 20秒
转印时间： 360秒

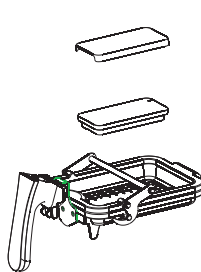

2、手机模具预热

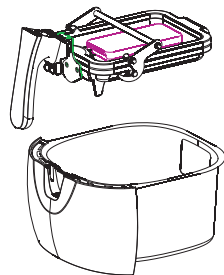

3、安装胶片

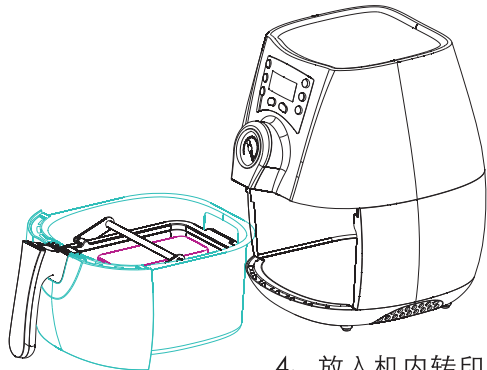

4、放入机内转印

Phone cases transfer printing-film printing image

Material:

- 1.3D sublimation special film
- 2.heat-proof plastic phone case or normal ABS plastic phone case
- 3.normal sublimation ink or low temperature sublimation ink
- 4.related printing phone case mould

Setting:

- 1.short press TIME SETTING,set time as 360 seconds.
- 2.long press TIME SETTING,set vacuum pump delay time as 20 seconds.
- 3.short press TEMPERATURE,set high temperature region as 160°C.
- 4.long press TEMPERATURE,set baking film temperature as 90°C.
- 5.long press “+” key,set vacuum pump and time to linked mode(ON).

Steps:

- 1.take down silicone rubber,replace specialized sealing strip.
- 2.press HEATING key,it starts heating up,the first time it can only heat up to 90°C.
- 4.when temperature achieves,keep temperature constant for 2 minutes,and the phone mould must be placed into the oven and preheated.
- 5.take out the tray,fix the sublimation film,then put it into the machine and press TIMING key.

FAQ:

1.the phone case is bigger or smaller than mobile phone and can't fit it?

Solution:if bigger then adjust temperature to 180°C,if smaller then adjust temperature to 150°C,and confirm your phone case type.

2.what you must pay special attention to while printing ABS plastic phone case?

First: your ink must be low temperature sublimation ink.

Second: temperature setting must be: high temperature is 110°C,baking film temperature is 80°C,time is 300 seconds.

Third: put your phone case into the oven and preheat it when you heat up the machine.

3.the air leaks when exhaust air?

Solution: replace a thick sealing strip,or use a hobnail to fix the upper sealing strip,or use medical tape to thicken the upper sealing strip.

4.the film was broken when exhaust air?

Solution: (1)if it breaks at the beginning,please lower the second stage baking film temperature to 80°C .If continuous operating,you must take out the pan,and lower the temperature to 80°C or below and then put into the film and exhaust air.

(2)if it breaks at the end,please lower the first stage temperature to 150°C.



1、Set parameter

Temperature: 160°C

Preheat temperature: 90°C.

Vacuum pump time delay: 20 seconds
(count down)

Transfer printing time: 360 seconds

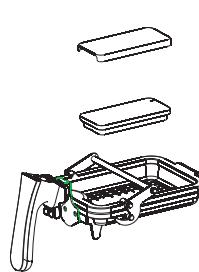

2、Preheat phone mould

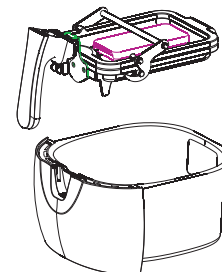

3、Fix film

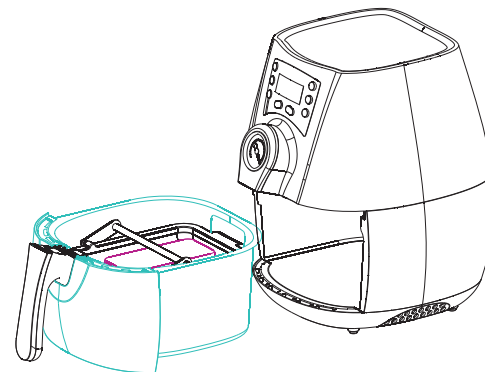

4、Put into the machine and transfer

11oz马克杯热转印效果图
effect picture of 11oz
sublimation mugs



11oz马克杯的制作方法

材料:

- 1、热转印专用纸, 打印图案尺寸为: 95x210mm
- 2、带涂层的11oz马克杯
- 3、尚美特公司开发的专用烤杯夹具
- 4、耐高温胶带和手套

制作方法:

- 1、将机器升温到**190度**, 首次升温应恒温2分钟。
- 2、时间设定为: **300秒**。
- 3、如下图所示范, 把杯子用烤杯夹固定好。
- 4、当温度达到后, 把贴好纸的杯子放入机器内。
- 5、印制**300秒**后, 拿出杯子。
- 6、如果需要同时印制几个杯子, 时间应相应添加。

印制**2个**杯子,时间设定为:**360秒**;

印制**3个**杯子,时间设定为:**450秒**;

印制**4个**杯子,时间设定为:**480秒**;

常见问题:

- 1、图案色彩不好, 纸上还有很多没有转印上去?
解决:有可能炉内温度还没有达到, 需要延长转印时间。
- 2、杯子上面有些发黄, 图案发虚?
解决: 请降低转印温度到180度, 时间也可适应减少一些。

11oz mug printing method

Material:

- 1.sublimation special paper,image printing size: 95x210mm
- 2.11oz coated blank mug
- 3.Sunmeta developed special heat press mug fixture
- 4.heat resisting tape and gloves

Steps:

- 1.heat up machine temperature to **190 °C**,first time use keep temperature constant for 2 minutes.
- 2.set time as **300 seconds**
- 3.As shown in the picture below,fix mug with mug fixture
- 4.when temperature achieves,put mug with stickup paper into the machine.
- 5.after printing **300 seconds**,take out the mug.
- 6.if print several mugs at a time,then time must be added.
for printing **two** mugs, set time as **360 seconds**,
for printing **three** mugs, set time as **450 seconds**,
for printing **four** mugs, set time as **480 seconds**.

FAQ:

- 1.the picture is not colorful,there is still some place that haven't been transferred on?
Solution: maybe the temperature is not enough,you must lengthen time.
- 2.there is some yellowing on the mug,and breezing image?
Solution: please lower temperature to 180 °C,and reduce some time properly.

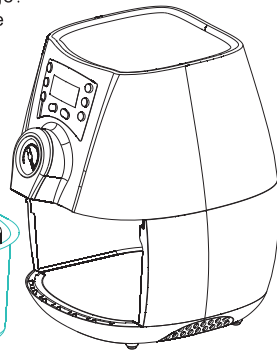
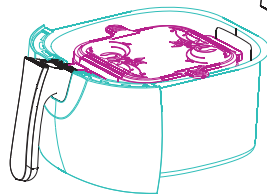
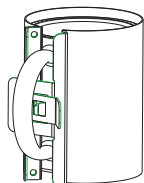
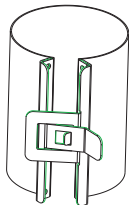
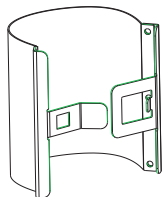

异型马克杯热转印效果图
effect picture of sublimation peculiar mugs



异型马克杯的制作方法

材料:

- 1、热转印专用纸, 跟据产品大小打印图案
- 2、马克杯表面需要带热转印涂层
- 3、尚美特公司开发的专用烤杯夹具

制作方法:

- 1、将机器升温到**190度**, 首次升温应恒温2分钟。
- 2、时间设定为: **600秒**。
- 3、如下图所示范, 把杯子放入烤杯夹内盖上面板。
- 4、当温度达到后, 把夹具放入机器内。
- 5、印制**600秒**后, 拿出杯子。

常见问题:

- 1、图案色彩不好, 纸上还有很多没有转印上去?

解决:有可能炉内温度还没有达到, 需要延长转印时间。

- 2、杯子上面有些发黄, 图案发虚?

解决: 请降低转印温度到180度, 时间也可适应减少一些。

Peculiar mug printing method

Material:

1. sublimation special paper,image printing size according to the product
- 2.the mug surface must be coated
- 3.Sunmeta developed special heat press mug fixture

Steps:

1. heat up machine temperature to **190 °C**,first time use keep temperature constant for 2 minutes.
- 2.set time as **600 seconds**.
- 3.As shown in the picture below,put the mug into fixture,and cover it.
- 4.when temperature achieves,put the fixture into the machine.
- 5.after printing **600 seconds**,take out the mug.

FAQ:

- 1.the picture is not colorful,there is still some place that haven't been transferred on?

Solution: maybe the temperature is not enough,you must lengthen time.

- 2.there is some yellowing on the mug,and breezing image?

Solution: please lower temperature to 180 °C,and reduce some time properly.

如图所示放入杯子 put cups in as shown



异型马克杯夹具
Peculiar mug fixture

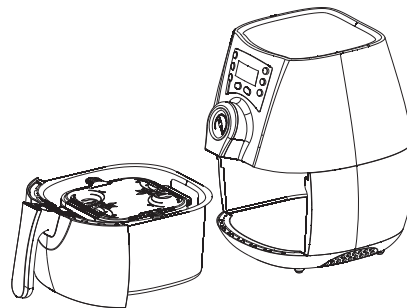
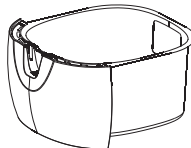
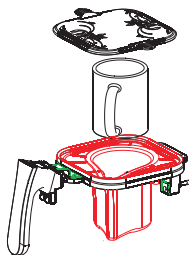

实用新型专利号: 201320845271.8
Patent for Utility models No.

高矮小酒杯热转印效果图
effect picture of sublimation High & Low wine glass



高、矮小酒杯的制作方法

材料:

- 1、热转印专用纸, 跟据产品大小打印图案
- 2、小酒杯表面需要带热转印涂层
- 3、尚美特公司开发的专用烤杯夹具

制作方法:

- 1、将机器升温到**190度**, 首次升温应恒温2分钟。
- 2、时间设定为:**480秒**。
- 3、如下图所示, 把杯子放入烤杯夹内盖上面板。
- 4、当温度达到后, 把夹具放入机器内。
- 5、印制**480秒**后, 拿出杯子。

常见问题:

- 1、图案色彩不好, 纸上还有很多没有转印上去?

解决:有可能炉内温度还没有达到, 需要延长转印时间。

- 2、杯子上面有些发黄, 图案发虚?

解决: 请降低转印温度到180度, 时间也可适应减少一些。

如图所示放入杯子 put cups in as shown



四孔烤杯夹具
four holes mug clamp

实用新型专利号: 201320845260.x
Patent for Utility models No.

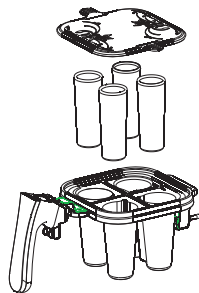

High & low small wineglass printing method

Material

1. sublimation special paper,image printing size according to the product
- 2.the small wineglass surface must be coated
- 3.Sunmeta developed special heat press wineglass fixture

Steps:

- 1.heat up machine temperature to **190 °C**,firt time use keep temperature constant for 2 minutes.
- 2.set time as **480 seconds**.
- 3.As shown in the picture below,put the wineglass into fixture,and cover it.
- 4.when temperature achieves,put the fixture into the machine.
- 5.after printing **480 seconds**,take out the wineglass.

FAQ:

- 1.the picture is not colorful,there is still some place that haven't been transferred on?

Solution: maybe the temperature is not enough,you must lengthen time.

- 2.there is some yellowing on the wineglass,and breezing image?

Solution: please lower temperature to 180 °C.and reduce some time properly.

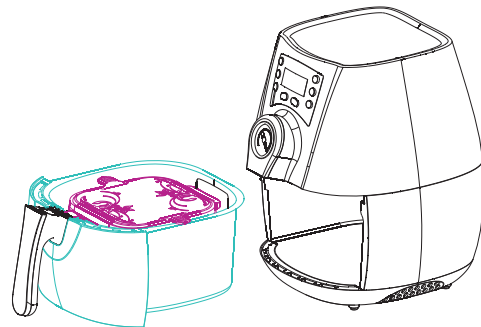

盘子热转印效果图

effect picture of sublimation plate



盘子的制作方法

材料:

- 1、热转印专用纸, 如果需要做月光盘需要专用胶片。
- 2、盘子表面需要带热转印涂层。
- 3、使用本公司开发的专用烤盘夹具。

制作方法:

- 1、将机器升温到**190度**, 首次升温应恒温2分钟。
- 2、时间设定为:**360秒**。
- 3、如下图所示, 把盘子安装好夹具后插上气管。
- 4、当温度达到后, 把夹具放入机器内, 气管会和机器相连。
- 5、印制**360秒**后, 拿出盘子。
- 6、如果使用胶片印制全幅面盘子: 应延时30秒, 把胶片烘软。

常见问题:

- 1、用纸张转印不了全幅面的盘子?

解决:请使用专用的3D胶片来制作全幅面的盘子。



Procedures for sublimation plates

Material:

1. Sublimation paper, or special film for full plate printing .
2. Plates with sublimation coating on the surface.
3. Special plate clamps designed by our company.

Procedures:

- 1.Preheat the machine to **190°C**.(if it's the first time you preheat, please wait for 2 minutes to let temperature in machine to be even, then start to transfer.)
2. Set time to **360 seconds**.
3. Put plate in the clamp, then connect to the pipe, see instruction pictures below.
4. after temperature reaching, put fixture into the machine, the airpipe will be connected with machine.
5. After **360 seconds**, take out the plate.
6. If you use special film to print full plate, should add more 30 seconds for baking the film soft.

FAQ:

- 1.I cannot use sublimation paper to print full plate, what should I do?
Answer: please use special film for full plate printing.

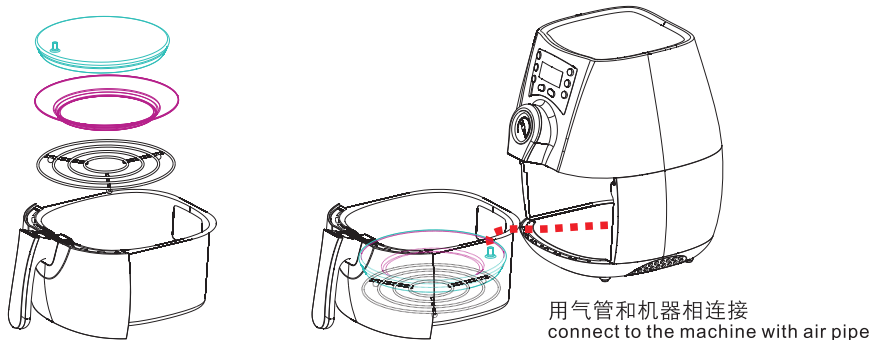

塑料直筒杯热转印效果图
effect picture of sublimation
plastic straight cup



塑料直筒杯的制作方法

材料:

- 1、热转印专用纸, 按产品大小把纸张裁切成扇形。
- 2、该杯子的塑料为特殊的耐高温塑料。
- 3、使用本公司开发的专用烤杯夹具。

制作方法:

- 1、将机器升温到**190度**, 首次升温应恒温2分钟。
- 2、时间设定为:**300秒**。
- 3、如下图所示范, 把杯子反过来放入夹具内, 插上气管。
- 4、当温度达到后, 把夹具放入机器内, 气管会和机器相连。
- 5、印制**300秒**后, 拿出杯子。
- 6、该夹具采用内外夹紧方式, 因此杯子内部也可印制图案。

常见问题:

- 1、转印图案时, 图案有虚条?

解决: 请用多条耐高温胶带把纸张贴牢, 上下左右都要贴胶带最少应该贴四根胶带, 让纸和杯子完全贴合。

- 2、杯子底部有些印不好?

解决: 当真空吸完后, 应把皮理顺一下。



Procedures for sublimation plastic straight cup

Material:

1. Sublimation paper, cut printed paper to fan shaped according to the mug size.
2. Material of the cup is special heat proof plastic.
3. Special mug clamps designed by our company.

Procedures:

1. Preheat the machine to **190°C**. (if it's the first time you preheat, please wait for 2 minutes to let temperature in machine to be even, then start to transfer.)
2. Set time to **300 seconds**.
3. Put cup in the clamp, bottom up, then connect to the pipe, see instruction pictures below.
4. after temperature reaching, put fixture into the machine, the airpipe will be connected with machine.
5. After **300 seconds**, take out the mugs.
6. The special mug clamp can be inner and exterior clamped, so you can also print picture inside the mugs.

FAQ:

1. When I transfer, there are dotted line on the picture?

Answer: please use heat proof tape to stick paper firmly on the products in each way, at least four tapes to promise firm enough.

2. I cannot print well on the bottom of cups, How to print it well?

Solutions: after vacuum out, straighten out the clamp at the bottom .

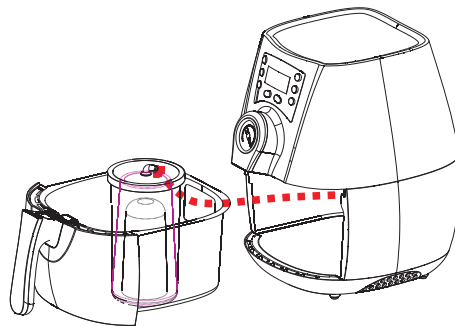

锥形杯热转印效果图

effect picture of sublimation conic cup



大、小锥形杯的制作方法

材料:

- 1、热转印专用纸, 按产品大小把纸张裁切成扇形。
- 2、杯子表面需要带热转印涂层。
- 3、使用本公司开发的专用烤杯夹具。

制作方法:

- 1、将机器升温到**190度**, 首次升温应恒温2分钟。
- 2、时间设定为: **450秒**。
- 3、如下图所示范, 把杯子反过来放入夹具内, 插上气管。
- 4、当温度达到后, 把夹具放入机器内, 气管会和机器相连。
- 5、吸气时请用手按住盖子二侧, 直到吸气完成后再次放开。
- 6、印制**450秒**后, 拿出杯子。
- 7、该夹具采用内外夹紧方式, 因此杯子内部也可印制图案。

常见问题:

- 1、转印图案时, 图案有虚条?

解决:请用多条耐高温胶带把纸张贴牢, 上下左右都要贴胶带最少应该贴四根胶带, 让纸和杯子完全贴合。



Procedures for sublimation conic mugs

Material:

1. Sublimation paper, cut printed paper to fan shaped according to the mug size.
2. Mugs with sublimation coating on the surface.
3. Special mug clamps designed by our company.

Procedures:

1. Preheat the machine to **190°C**. (if it's the first time you preheat, please wait for 2 minutes to let temperature in machine to be even, then start to transfer.)
2. Set time to **450 seconds**.
3. Put mug in the clamp, bottom up, then connect to the pipe, see instruction pictures below.
4. after temperature reaching, put fixture into the machine, the airpipe will be connected with machine.
5. During vacuum, please press the two sides of machine by hand until it vacuums out.
6. After **450 seconds**, take out the mugs.
7. The special mug clamp can be inner and exterior clamped, so you can also print picture inside the mugs.

FAQ:

1. When I transfer, there are dotted line on the picture, what should I do?

Answer: please use heat proof tape to stick paper firmly on the products in each way, at least four tapes to promise firm enough.

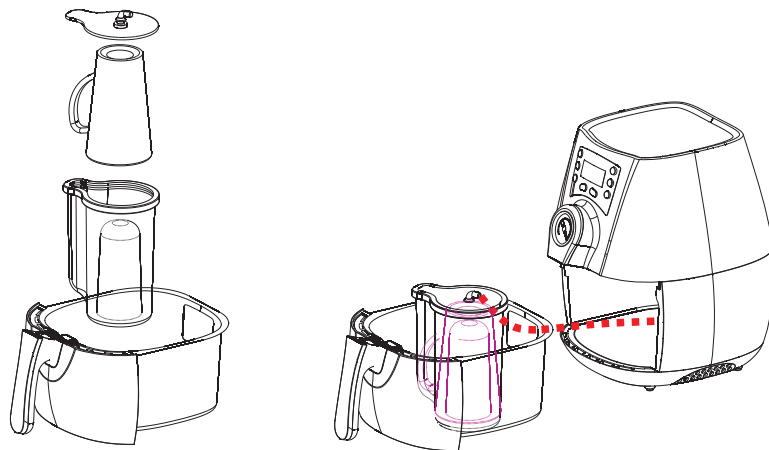

安全警告：

- 请勿使用和本机不配套的电源电压，以免造成触电、火灾等意外。
- 请单独使用7A以上的插座，若与其他电器并用容易造成电源线发热破损。
- 电源线请勿强力拉扯扭曲，以免造成电线破损。如果电源线有损坏，请由制造商或专业电工进行更换。
- 请勿用潮湿的手拔插头，否则容易引发触电。
- 请勿让孩童接触插头及机器，以免造成触电或烫伤。
- 请放置在离墙壁或家具30公分以外的地方，否则热气会损伤墙壁或家具。
- 请勿将产品放置在易燃物上易燃物附近。如桌巾或窗帘，以勿引起火灾危险。

Security Warning:

- Don't use unmatched power/voltage, in case of electric shock or fire.
- Please use single socket above 7A, if using together with other electric appliances, it may cause electric line hot or even broken.
- Don't pull or warp electric wire strongly, in case of electric wire breaks. If the electric wire was broken, please let manufacturer or electrician change it.
- Don't pull out plug with wet hand, otherwise it may cause electric shock.
- Don't let children touch the plug and machine, in case of electric shock or scald.
- Please keep the machine away from wall or furniture 30cm beyond, otherwise the hot air may damage wall or furniture.
- Don't put the machine near inflammables such as tablecloth or curtain, in case of fire disaster.

功率参数表：

| | |
|--------|-------------------|
| 产品名称： | MINI型真空热转印机 |
| 产品型号： | ST-1520 |
| 额定电压： | 230V(另选100V~120V) |
| 额定频率： | 50Hz(另选50-60Hz) |
| 总功率： | 1300W |
| 发热管功率： | 1200W |
| 真空泵： | 12V 10W |
| 真空压力： | -0.06~-0.07Pa |
| 匀热风机： | 80W |
| 工作面积： | 150mmX200mmX20mm |
| 包装尺寸： | 345X370X350mm |
| 整机净重： | 6kg |

Power parameters:

product name: mini 3D sublimation vacuum heat press machine
product model: ST-1520
nominal voltage: 230v/(100v~120V)
rated frequency: 50hz/(50-60hz)
rated power: 1300w
heating tube power: 1200w
vacuum pump: 12v, 10w
vacuum pressure: -0.06~0.07pa
heat blower: 80w
printing size: 150mmx200mmx20mm
package size: 345x370x350mm
net weight: 6kg

产品保修卡 Product warranty card

名称：迷你型真空热转印机 FREESUB Machine

型号：ST-1520

| | | | |
|------------------------|-------|------------|--|
| 姓名 Full name | | 生产批号 | |
| 联系电话 Tel: | | | |
| 联系地址 Address | | | |
| E-mail: | | | |
| 商品序号 No. | | | |
| 购买日期 Date of purchase: | 年 月 日 | 经销商 Dealer | |

承蒙惠顾，万分感谢，为确保你的权益，请要求经销商填写购买信息，并加盖店章，方可享有本公司一年内免费保修服务。
Thanks for your patronage, for the sake of your rights and interests, please ask the distributor to fill in your purchase information and stamp on it, thus can enjoy our company's one year free maintaining service.

保修说明 Warranty Description

一、保修内容：

1. 免费服务：自购买日起一年内
2. 免费服务范围：国内机器一年内可免费更换相关配件，易损件除外。
3. 运输费用：国内客户本三个月内本公司负责往返运费，不负责国外客户海外运费。

二、如有以下情况者，不在保修范围内

1. 产品故障认为（如外力破坏、供电系统失误等等）、天灾（含淹水、雷击、地震）等因素者。
2. 主体以外附件，如真空硅胶皮、密封条、夹具等。
3. 消耗零件。
4. 无法出示保修卡、发票、购买日期等，视同自行放弃保修权益。所以请妥善保管本卡片。



请沿此处裁切

F R E  S U B

自由转印 尽显色彩

BEAUTY YOURLIFE